

Print ISSN: 1095-6298  
Online ISSN: 1528-2678

## About the Academy of Marketing Studies

Academy of marketing studies journal (AMSJ) is a globally renowned business and marketing journal that offers an open access forum for the professionals, practitioners, academicians, researchers, and students to share and discuss the latest trends and developments in this field from across the world.

Affiliated to the allied business academy publications, AMSJ adheres to stringent double peer review to enhance the research quality and originality. With 30% of acceptance, AMSJ invites authors and professional to contribute their live and current marketing experiences as theoretical or empirical studies. More details on the types of manuscripts published and the categories of research accepted are displayed in the journal matrix section of this website.

### Peer review policy:

Academy of marketing studies Journal follows the Single blind peer review process. Every submitted manuscript processed for preliminary quality control check by editorial office followed by external peer review process.

Usually preliminary quality control completes within seven days and is majorly with reference to journal formatting, English and journal scope.

Sponsored by the academy of marketing studies, AMSJ includes a broad category of themes in the field of marketing, including but not limited to foreign market network, market opportunities, network competence, branding strategies, personalized e-commerce, e-satisfaction and e-loyalty buying attributes, e-marketing and online fraud, marketing in banking sector, efficient marketing plan, consumer satisfaction and eccentric business communication for study.

Authors who would like to discuss the potential interest in a manuscript may contact editorial staff.

## h-index

Articles published in **Academy of Marketing Studies Journal** have been cited by esteemed scholars and scientists all around the world. **Academy of Marketing Studies Journal** has got h-index 36, which means every article in Academy of Marketing Studies Journal has got 36 average citations.

## Volume Selector

### 2022

[Volume 26, Issue 2](#)

[Volume 26, Issue 1](#)

[Volume 26, Special Issue 2](#)

[Volume 26, Special Issue 1](#)

### 2021

[Volume 25, Special Issue 2 \(Title: Marketing Strategies- Covid 19\)](#)

[Volume 25, Issue 6](#)

[Volume 25, Issue 5](#)

[Volume 25, Issue 4](#)

[Volume 25, Issue 3](#)

[Volume 25, Issue 2](#)

[Volume 25, Issue 1](#)

[Volume 25, Special Issue 3 \(Title: Marketing Study\)](#)

[Volume 25, Special Issue 1 \(Title: Covid-19 Effect on Marketing and Banking Sector\)](#)

### 2020

### Editor-in-Chief

Submit Queries Here, Direct to Journal Email and Submit the new manuscript [marketingstudy@abacademies.org](mailto:marketingstudy@abacademies.org)

### Rohaizat Baharun

Azman Hashim International Business School

### Dr. Nirmai Kumar Betchoo

Dean of Faculty, Business & Management, 2016-19 Senior Lecturer in Management, HRM, International Business at ex-SDIM First Head of Department, Management and Communication 2002-2004

You may submit manuscripts online at:

[www.abacademies.org/submissions/academy-of-marketing-studies-journal.html](http://www.abacademies.org/submissions/academy-of-marketing-studies-journal.html)

H Index: 15 | Google Scholar h5 index: 12

### Google scholar citation report

Citations : 6351

Academy of Marketing Studies Journal received 6351 citations as per google scholar report



### Academy of Marketing Studies Journal peer review process verified at publons

### Abstracted/Indexed in

- (DRJI)
- > OCLC- WorldCat
- > Publons
- > Scientific Indexing Services (SIS)
- > Google Scholar
- > Euro Pub
- > ABDC
- > Cengage Gale
- > Mirabel



## 2019

[Volume 23, Issue 4](#)

[Volume 23, Issue 3](#)

[Volume 23, Issue 2](#)

[Volume 23, Issue 1](#)

## 2018

[Volume 22, Issue 4](#)

[Volume 22, Issue 3](#)

[Volume 22, Issue 2](#)

[Volume 22, Issue 1](#)

## 2017

[Volume 21, Issue 2](#)

[Volume 21, Issue 1](#)

## 2016

[Volume 20, Special Issue 1](#)

[Volume 20, Special Issue](#)

[Volume 20, Issue 3](#)

[Volume 20, Issue 2](#)

[Volume 20, Issue 1](#)

## 2015

[Volume 19, Number 3](#)

[Volume 19, Number 2](#)

[Volume 19, Issue 1](#)

## 2014

[Volume 18, Issue 2](#)

[Volume 18, Issue 1](#)

## 2013

[Volume 17, Issue 2](#)

[Volume 17, Issue 1](#)

## 2012

[Volume 16, Issue 2](#)

[Volume 16, Issue 1](#)

## 2011

[Volume 15, Issue 2](#)

[Volume 15, Issue 1](#)

## 2010

[Volume 14, Issue 2](#)

[Volume 14, Issue 1](#)

## 2009

> Euro Pub

[Read More](#)

**Available From**  
1997 - 2022

**Volumes**  
26

**Issues**  
26

**Articles**  
488

**Academy of Marketing  
Studies Journal**

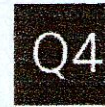

Economics and  
Econometrics

best quartile

SJR 2017

0.12



powered by scimagojr.com

Get the App





## Relevant Topics

[Architectural-Engineering-And-Design-Management](#)

[Astroparticle Physics Scholarly Journals](#)

[Bioinoculants Peer Reviewed Journals](#)

[Biological Engineering-journals](#)

[Biological Pest Control Peer Reviewed Journals](#)

[Biopolymers Precursors Innovations](#)

[Bioprotectants Top Journals](#)

[Architectural-Engineering-And-Design-Management](#)

[Bioinoculants Impact Factor](#)

[Bioinoculants Peer Reviewed Journals](#)

[Biological Pest Control Articles](#)

[Biological Pest Control Peer Reviewed Journals](#)

[Bioprotectants Open Access Journals](#)

[Bioprotectants Top Journals](#)

[Astroparticle Physics Scholarly Journals](#)

[Bioinoculants Impact Factor](#)

[Biological Engineering-journals](#)

[Biological Pest Control Articles](#)

[Biopolymers Precursors Innovations](#)

[Bioprotectants Open Access Journals](#)

[Biotin Deficiency And Restless Legs Syndrome](#)

Allied Business Academies publishing a total of 14 different journals in various fields of business. With an acceptance rate of 30%, each of the journals of our affiliates is double blind, peer reviewed and some of the journals are listed in SCOPUS, SCIMAGO, Google Scholar, ProQuest, Cengage Gale, LexisNexis and several other academic databases and search engines

## Follow Us



## Quick Links

- [📖 Journals](#)
- [📖 Matrix](#)
- [📖 Proceedings](#)
- [📖 Guidelines](#)
- [📖 About Us](#)
- [📖 Member Services](#)

## Contact Info

- 📍 Allied Business Academies  
40 Bloomsbury Way Lower  
Ground Floor  
London, United Kingdom  
WC1A 2SE  
Registered Address  
3 SHENTON WAY  
#10-05  
SHENTON HOUSE  
SINGAPORE (068805)
- 📞 (+ 44-2036082719)
- ✉️ [contactus@abacademies.org](mailto:contactus@abacademies.org)

Get the App





Articles in issue: 4 | Volume: 23 | Month: December | Year: 2019

[An Enhancement of Takaful Marketing in Malaysia in the 21st Century](#)

**Author(s):** Dr. Yusuff Jelili Amuda, Wan Nuraini Binti Wan Din, Nursyafiqah Binti Ibrahim and Nurdiyanah Afiqah Binti Noraman

[Abstract](#) [Full-Text](#) [PDF](#)

[Customer Value in Improving Indihome Customer's Trust in West Java](#)

**Author(s):** Erica Nurmartiani, Sucherly, Meydia Hasan and Rita Komaladewi

[Abstract](#) [Full-Text](#) [PDF](#)

[Economic Benefit and Implication of Exploring Prisoners Employment: Scholars Perspective for Case of the Nigerian Inmates in Malaysia](#)

**Author(s):** Yusuff Jelili Amuda, Abideen Adeyemi Adewale and Oladokun Nafiu Olaniyi

[Abstract](#) [Full-Text](#) [PDF](#)

[Relationship between Service Quality and Customer Satisfaction in Airlines Industry](#)

**Author(s):** A. Thirunavukkarasu and V. R. Nedunchezian

[Abstract](#) [Full-Text](#) [PDF](#)

[Factors Effecting Purchase Frequency in Turkey: An Application on Smart Phones](#)

**Author(s):** Baris Batuhan Gecit

[Abstract](#) [Full-Text](#) [PDF](#)

[Antecedents from Purchase Intention of Retail Brand X Evidence from Indonesia](#)

**Author(s):** Willy Arafah, Nico Lukito and Richardus Rikang

[Abstract](#) [Full-Text](#) [PDF](#)

[Predictors of Customer Loyalty: A Case of Indian Mobile Telecommunication Services Sector](#)

**Author(s):** Vikas Gautam

[Abstract](#) [Full-Text](#) [PDF](#)

[Decision Model Based on Technology Acceptance Model \(Tam\) for Online Shop Consumers in Indonesia](#)

**Author(s):** Dede Suleman, Ida Zuniarti, Sabil, Eka Dyah Setyaningsih, Vera Agustina Yanti, Isnurrini Hidayat Susilowati, Imelda Sari, Sofyan Marwansyah, Seno Sudarmono Hadi and Amin Setio Lestiniingsih

[Abstract](#) [Full-Text](#) [PDF](#)

[Price Discount and Gift Choice: Interplay between Economic and Social Value](#)

**Author(s):** Zhuofan Zhang

[Abstract](#) [Full-Text](#) [PDF](#)

[Mobile Internet use by Generation Z: Evidence from an Emerging Market](#)

**Author(s):** Rania S. Hussein and Mahmoud Attia

[Abstract](#) [Full-Text](#) [PDF](#)

[The Influence of Selfies on Product and Image Evaluation](#)

**Author(s):** Patrick A. Barbro

[Abstract](#) [Full-Text](#) [PDF](#)

[How Social Media Communications can Mitigate Negative Impacts of Corporate Social Irresponsibility on Corporate Financial Performance?](#)

**Author(s):** Saad A. Alhoqail, Hyun Young Cho and Kristopher Floyed

[Abstract](#) [Full-Text](#) [PDF](#)

[Success of Malls in an Emerging Market: An Evaluation beyond Huffs Model](#)

**Author(s):** Subhendu Dey, Jayanta Banerjee and Bibhutesh Nayak

[Abstract](#) [Full-Text](#) [PDF](#)

[Abstract](#) [Full-Text](#) [PDF](#)

### [Creating Consumer Personality Profile by Using 3m Model and Paradoxes of Technology](#)

**Author(s):** Angelica Bahl and Sally Baalbaki-Yassine

[Abstract](#) [Full-Text](#) [PDF](#)

### [The Effect of Customer Prioritization Strategy on Customer Entitlement](#)

**Author(s):** Svetlana V. Davis

[Abstract](#) [Full-Text](#) [PDF](#)

### [The Problematic use of Smartphone and Fomo as Antecedents of Facebook Addiction](#)

**Author(s):** Housseem Edine Nasr and Kaouther Saied Ben Rached

[Abstract](#) [Full-Text](#) [PDF](#)

### [Marketing Artificial Intelligence: Creating the AI Archetype for Evoking the Personality Trust](#)

**Author(s):** Gulnara Z. Karimova and Amir Shir Khanbeik

[Abstract](#) [Full-Text](#) [PDF](#)

### [Learning from Semantic Inconsistencies as the Origin of Dynamic Capabilities in Mncs: Evidence from Pharmaceutical Mncs](#)

**Author(s):** Isar Kiani, Pouya Seifzadeh and Ian Alam

[Abstract](#) [Full-Text](#) [PDF](#)

## Follow Us.

## Quick Links

[Academies](#)  
[Journals](#)  
[Matrix](#)  
[Proceedings](#)  
[Guidelines](#)  
[About Us](#)  
[Member Services](#)

## Contact Info

Allied Business Academies  
40 Bloomsbury Way Lower Ground  
Floor  
London, United Kingdom  
WC1A 2SE  
(828) 214-3944  
[contact@abacademies.org](mailto:contact@abacademies.org)

## Editorial Board

Academy of Marketing Studies Journal (AMSJ) is an open access publication affiliated to the Allied Business Academies. The Editorial Board of the AMSJ exercises complete control over the editorial content of the Journal and it is published Bi-monthly. AMSJ invites authors to submit manuscripts throughout the year to get accommodated in any of these editions. The Journal welcomes participants in its associated conferences to submit their manuscripts for accelerated review.

AMSJ encourages theoretical and empirical research on the market opportunities and branding strategies to explore recent trends in this field like E-marketing. All the manuscripts submitted for publication are subjected to a thorough double blind peer review process. The journal aims to expand the horizon of this scientific discipline by sharing the latest trends and developments to further the reader's understanding of Marketing and Branding.

More details related to the types of manuscripts published and the categories of research accepted in AMSJ are displayed in detail in the Journal Matrix section of this website. Individuals that are keen in joining the Editorial Board should contact the Editorial staff. The Journal is interested in expanding its editorial board and solicits inquiries.

For more information about submitting your manuscript for consideration, please visit our 'Submit Manuscript page' in the website.

### Editors-in-Chief

**Submit Queries Here, Direct to Journal Email and Submit the new manuscript**  
marketingstudy@abacademies.org

**Rohaizat Baharun**  
Azman Hashim International Business School

**Dr. Nirmal Kumar Betchoo**  
Dean of Faculty, Business & Management, 2016-19 Senior Lecturer in Management, HRM, International Business at ex-SDIM First Head of Department, Management and Communication 2002-2004

### Associate Editor

**Anuj Kumar**  
Assistant Professor, Apeejay School of Management (International Business and Marketing)

**Dr Pabitra Kumar Jena**  
Shri Mata Vaishno Devi University, India

### Editorial Board

**Prof. Zhou Jie, Phd**  
Associate Professor and master supervisor in College of Tourism and Service Management, Nankai University, China

**Dr. Masoud Lajevardi, Phd**  
Assistant Professor of marketing management, Islamic Azad University of Iran, Iran.

**Dr. Debarun Chakraborty, Phd**  
Associate Professor & Research Head in Symbiosis Institute of Business Management (SIBM), Nagpur, Constituent of Symbiosis International (Deemed University), Pune.

**Dr. Roop Lal Sharma, Phd**  
Assistant Professor, Shri Mata Vaishno Devi University, India

**Dr. Ratish C Gupta, Phd**  
Currently associated with Daly College Business School (Affiliated to De Montfort University UK) as Faculty M

Get the App



**Dr. Chia-Huei Wu, Phd**  
Assistant Professor at Minghsin University of Science Technology in Taiwan, Taiwan.

**Alimnazar Islankudov**  
Academy of Public Administration under the President of the Republic of Uzbekistan

**Dr. Ching-chih Chou, Phd**  
Associate professor, School of Management, Zhongshan Institute, University of Electronic Science and Technology of China, China.

**Dr. Nimit Gupta**  
Professor in Management, The NorthCap University, Gurugram, India

**Murat Emikonel**  
Kocaeli University, Turkey.



## Editorial Review Board

**Mufutau Akanbi Awoniyi**  
Lagos State University

**Hai Wang**  
Southeast University, China

**Pradip Kumar Sharma**  
Seoul National University of Science and Technology

**Prashant Kumar**  
The T.A. Pai Management Institute

**CHEN, Shu-Ching**  
University of Adelaide

**Colla Enrico**  
ESCP-Europe Business School

**Valeriya Shapoval**  
University of Central Florida

**Abu Saleh**  
University of Canberra, Australia

**Saradhi Motamamri**  
Institute for Infocomm Research, A-Star, Singapore

**Fred Chao**  
University of Newcastle, Australia

**Crystal Yap**  
Auckland University of Technology

**K. Abdul Waheed**  
Institute of Management Technology

**Manisha Gupta**  
Sharda University

**Dr. KIRAN SONI, Ph.D**  
Associate Professor at Geetanjali Institute of Management &  
Technology, Udaipur, INDIA

**Dr Vinod A S, Ph.D**  
Assistant Professor, PG Department of Commerce, Mahatma  
Gandhi College, Trivandrum, Kerala, INDIA.

**Zeki Atil Bulut**  
Dokuz Eylul University

Get the App

**Aijun Liu**  
Xidian University



**Jiafu Su**  
Chongqing Technology and Business University

**Hira Batool**  
Walailak University, Thailand

**Jorge Bullemore Campbell, PhD**  
Adjunt Professor and Researcher, Univeridad del Desarrollo, Chile

**Jishnu Bhattacharyya, FPM Scholar, Indian Institute of  
Management, Kozhikode.**  
FPM Scholar, Indian Institute of Management, Kozhikode.

**Asmat Ara Shaikh**  
Assistant Professor, Bharati Vidyapeeth's Institute of Management  
Studies and Research, Navi Mumbai

**Purvi Pujari**  
Associate Professor, Bharati Vidyapeeth's Institute of Management



Assistant Professor, Royal School of Commerce Royal Global  
University Guwahati Assam, India

**Aruna Dev Rroy**

Assistant Professor, Royal School of Commerce, Royal Global  
University Guwahati Assam, India

**Srilalitha Sagi**

Associate Professor, Head of the Department, International Business  
GITAM School of Business, GITAM Deemed to be University, Andhra  
Pradesh India

**Emily L. Pan**

professor of MBA program at Silicon Valley Business Institute  
(SVBI), Milpitas, Los Angeles, CA

**Hossien Moghimi Esfandabadi**

University of Tehran

**Gholam Reza Zandi**

University Kuala Lumpur

**Sajjad Ahmad Baig**

University of Punjab

**Mufutau Akanbi Awoniyi**

Lagos State University

**Morteza Abolhasani**

The Open University

**Prahalad Sooknanan**

University of Trinidad and Tobago

**Giuseppe Festa**

University of Salerno

**Vinod Kumar**

Indian Institute of Technology

**Lianda W. Mauyo**

Masinde Muliro University of Science and Technology

**Timothy W. Aurand**

NIU College of Business

**Kevin D. Bradford**

University of California

**Scott D. Swain**

Clemson University

**Gary Brunswick**

Arizona State University

**Donald Sexton**

Emeritus of Business

**Ibrahim Alnawas**

Al-Petra University Jordan

**Marlene C. Kahla**

Stephen F. Austin State University

**Cynthia Hanson**

High Point University

**Martin S. Meyers**

University of Wisconsin at Stevens Point

**Martin Bressler**

Southeastern Oklahoma State University

**Brent L. Baker**

University of North Dakota

**David Price**

Washburn University

**Susan Geringer**

Get the App





Niagara College, Canada

**Jacqueline Williams**  
North Carolina A&T State University

**Kelly Bruning**  
Walden University

**Ashley Kilburn**  
University of Tennessee Martin

**Val Larsen**  
James Madison University

**Rujirutana Mandhachitara**  
Pennsylvania State University

**Peter J. Gordon**  
Southeast Missouri State University

**M. Wayne Alexander**  
Minnesota State University Moorhead

**M.J. Alhabeeb**  
University of Massachusetts

## Relevant Topics

[Architectural-Engineering-And-Design-Management](#)

[Astroparticle Physics Scholarly Journals](#)

[Bioinoculants Peer Reviewed Journals](#)

[Biological Engineering-journals](#)

[Biological Pest Control Peer Reviewed Journals](#)

[Biopolymers Precursors Innovations](#)

[Bioprotectants Top Journals](#)

[Biotin Deficiency And Restless Legs Syndrome](#)

[Civil-engineering-journals](#)

[Construction-building-journals](#)

[Financial-Market-High-Impact-Factor-Journals](#)

[Financial-Market-Scientific-Journals](#)

[Freely Available Journals In Cancer](#)

[Imaging Mass Spectrometry Impact Factor](#)

[Landscape-Architecture](#)

[Melanin Top Journals](#)

[Tissue Impact Factor](#)

[Weed Management Impact Factor](#)

[Weed Management Top Journals](#)

[Architectural-Engineering-And-Design-Management](#)

[Bioinoculants Impact Factor](#)

[Bioinoculants Peer Reviewed Journals](#)

[Biological Pest Control Articles](#)

[Biological Pest Control Peer Reviewed Journals](#)

[Bioprotectants Open Access Journals](#)

[Bioprotectants Top Journals](#)

[Bubble Column Reactors Peer-review Journals](#)

[Civil-engineering-journals](#)

[Exotic-Architecture](#)

[Financial-Market-High-Impact-Factor-Journals](#)

[Financial-Market-Top-Journals](#)

[Freely Available Journals In Cancer](#)

[Integrated Pest Management Top Journals](#)

[Landscape-Architecture](#)

[STR Markers Articles](#)

[Tissue Impact Factor](#)

[Weed Management Open Access Journals](#)

[Weed Management Top Journals](#)

[Astroparticle Physics Scholarly Journals](#)

[Bioinoculants Impact Factor](#)

[Biological Engineering-journals](#)

[Biological Pest Control Articles](#)

[Biopolymers Precursors Innovations](#)

[Bioprotectants Open Access Journals](#)

[Biotin Deficiency And Restless Legs Syndrome](#)

[Bubble Column Reactors Peer-review Journals](#)

[Construction-building-journals](#)

[Exotic-Architecture](#)

[Financial-Market-Scientific-Journals](#)

[Financial-Market-Top-Journals](#)

[Imaging Mass Spectrometry Impact Factor](#)

[Integrated Pest Management Top Journals](#)

[Melanin Top Journals](#)

[STR Markers Articles](#)

[Weed Management Impact Factor](#)

[Weed Management Open Access Journals](#)

Get the App



Allied Business Academies publishing a total of 14 different journals in various fields of business. With an acceptance rate of 30%, each of the journals of our affiliates is double blind, peer reviewed and some of the journals are listed in SCOPUS, SCIMAGO, Google Scholar, ProQuest, Cengage Gale, LexisNexis and several other academic databases and search engines.

## Quick Links

- [Journals](#)
- [Matrix](#)
- [Proceedings](#)
- [Guidelines](#)
- [About Us](#)

## Contact Info

- [Allied Business Academies  
40 Bloomsbury Way Lower  
Ground Floor  
London, United Kingdom  
WC1A 2SE  
Registered Address](#)

Follow Us



# ANTECEDENTS FROM PURCHASE INTENTION OF RETAIL BRAND “X”: EVIDENCE FROM INDONESIA

Willy Arafah, Trisakti University  
Nico Lukito, Trisakti University  
Richardus Rikang, Trisakti University

## ABSTRACT

*The purpose of this study was to determine in what extent e-service quality influences brand love, word of mouth, and purchase intention, furthermore how brand love influence word of mouth and purchase intention, as well as the influence of word of mouth to purchase intention, the study was conducted on one online application by (Brand “X”). This research revealed that e-service quality affects brand love, word of mouth, and purchase intention. Likewise, brand love influences word of mouth, and purchase intention, additionally word of mouth has a significant effect on purchase intention on (Brand “X”) consumers. The limitations of this study are the number of respondents who use the (Brand “X”) application. As a matter of fact, it is suggested that (Brand “X”) introduce online applications further to its consumers because it was expected that online application could build consumer's' love for the brand towards (Brand “X”) products, create positive word of mouth, and ultimately raise consumer willingness to shop (Brand “X”) products.*

**Keywords:** Brand Love, E-Service Quality, Home Furnish, Online App, Purchase Intention, Word of Mouth.

## INTRODUCTION

Based on survey data conducted by the Indonesian Internet Service Providers Association (APJII) in 2017, 54.68% of Indonesia's total population or around 143.26 million Indonesians are internet users, the number of which continues to increase from year to year including compared to year 2016 which has reached 132.7 million. According to Bressolles & Durrieu (2011) e-service quality is defined as the condition of consumers or customers can shop, search for products, buy products until delivery through facilities provided via electronic or existing sites. Conducted by Kassim & Abdullah (2010) by utilizing the internet or online website, companies can increasingly increase revenue in new ways and increasingly open opportunities for companies and consumers to interact. Fournier & Mick (1999) also said the brand or brand created by each company is made to further increase satisfaction for consumers, satisfaction due to the love of the brand can build satisfaction that is stronger and deeper in all aspects of satisfaction. Carroll & Ahuvia (2006) introduced a new marketing strategy called brand love. Brand love or love of the brand is a consumer satisfaction with a level of emotional bond that is passionate to have a product that emerges from within the consumer itself. Brand love is an important role for a consumer when deciding to buy a product. Consumers love a brand because of their interest in brands, which in turn can inspire a consumer (Ismail & Spinelli, 2012).

The existence of consumers has a significant contribution in marketing products, both goods and services from a company. This is often referred to as word of mouth or the delivery of information directly from consumers to other potential customers. Consumer purchasing



behavior is currently strongly influenced by word of mouth, that is, recommendations or suggestions from closest colleagues have more potential to be more trusted than commercial sources such as advertising. Word of mouth usually occurs naturally, that is when a consumer feels satisfied with a product, then tells the product to someone else (Kotler & Keller, 2012).

Based on this background, so the research problems can be formulated as follows: (1). Is there an effect of e-service quality on brand love on online application users?; (2). Is there an effect of e-service quality on word of mouth on online application users? ; (3). Is there an effect of e-service quality on purchase intention on online application users? ; (4). Is there an influence of brand love on word of mouth on online application users? ; (5). Is there influence of brand love on purchase intention on online application users? ; (6). Is there an effect of word of mouth on purchase intention on online application users?. Therefore, the purpose of this research to explore the issues outlined. This kind of investigations is important because when the company decided e-service quality it's will influence to purchase intention, but in this research we look at one case in Indonesia retail product.

## LITERATURE REVIEW AND HYPOTHESES DEVELOPMENT

### E-Service Quality

According to previous research conducted by Ho & Lee (2007) there are five dimensions of e-service quality measurement, namely: (1). Information quality is information available on the website. (2). Security is the extent to which a website is proven and reliable for its customers. (3). Website functionality consists of three aspects: (a). Navigation. (b). Access the website. (c). Transactional function. (4). Customer relationship, what is meant is a virtual community or forums that are formed through the same interest in a product or only as limited as the user, "*gathering*" in a forum to convey opinions and opinions and exchange information between consumers with one another regarding a product or services. (5). Responsiveness and fulfillment are measured based on the extent to which existing websites respond to consumers, both like answering questions from consumers quickly and efficiently or responding to complaints from consumers politely.

Then according to Parasuraman et al. (1988) also identified five dimensions of service quality related to what is desired by consumers, namely: (1). reliability. (2). assurance. (3). tangibles. (4). empathy. (5). responsiveness. so according to parasuraman, consumers use these five dimensions to determine the extent to which the quality of services provided by producers to what is needed by consumers. According to Chase et al. (2006) e-service quality can be defined as an increase in service from producers through existing internet media such as websites, where consumers can find needs or shop, make purchases, and distribute effectively and efficiently with internet media.

### Brand Love

Carroll & Ahuvia (2006) define brand love as a very strong level of desire or passionate emotional attachment from within consumers to have a particular brand. In a previous study by Santos (2003) brand love has 5 (five) dimensions of measurement, namely: (1). Passion for a brand is where consumers feel passionate about buying and owning a product with a certain brand. (2). Brand attachment is a condition where consumers feel tied to a brand of a product. (3). Positive evaluation of the brand is a condition where after a consumer uses or uses a product



with a particular brand, the consumer will provide feedback in the form of testimonials or suggestions on the product. (4). Positive emotions in response to the brand are conditions where when consumers consume products with a brand, consumers will feel positive emotions. (5). Declarations of love toward the brand are declarations from consumers which are a form of love for the brand. According to Fournier (1998) brand love is also an attachment between a product and a particular brand of consumers, where consumers have a high level of satisfaction to own the brand. According to Thomson & Park (2005) brand love is also a psychological condition where the attitudes and behavior of consumers who have an emotional relationship with the brand, which is related to consumer attitudes towards the products offered by the brand.

### **Word of Mouth**

Hasan (2010) said that word of mouth is a positive experience of consumers of services and products that really influence the purchasing decisions or behaviors of these consumers which are then conveyed in the form of praise, recommendations and positive comments. According to Kotler & Keller (2012) word of mouth marketing is the activity of marketing products and services through intermediaries to people related to the experience of buying or using a product and service by means of oral, written or electronic communication media. Based on the research of Wasim (2017) word of mouth consists of two types, namely: organic word of mouth and amplified word of mouth. Organic word of mouth is a conversation that occurs naturally or naturally and just goes on the basis of the positive qualities of the company.

### **Purchase Intention**

Belch (2004) said purchase intention is the suitability between the motives of purchase with the attributes or characteristics of a brand of products that have been previously considered for the next process of buying the product. According to Engel (2002) purchase intention is related to two categories, namely: (1). Purchase intention where the condition of consumers is indeed an interest in certain products and brands, if a product is a different brand, maybe the consumer discourages him from buying; (2). Purchase intention where the condition of consumers is interested in the product only, so that if the consumer wants a product, the consumer is free to choose an existing brand, even though later the decision to choose the brand is made at the planned purchase. Purchase intention shows how far individuals have the ability to buy certain brands that are chosen after evaluating according to Khan et al. (2012). Peter & Olson (2008) also argue that the attitude of a consumer in buying a product or service is based on the desire or intention of the consumer to buy the desired product and service.

### **Hypothesis Development**

In this research, researchers wanted to find out the effect of e-service quality on brand love on online application users, previous research conducted by Sundaram et al. (2017) and the other research by Al-dweeri (2017) and Mohammed et al. (2016) said that there is an influence of e-service quality on brand love, so we can formulate the hypothesis as follows:

*H1: There is an influence of e-service quality on brand love on online application users.*



Several previous research conducted by Zeglal et al. (2016) and Ting et al. (2016) and Syahrivar & Ichlas (2018) said that there was an effect of e-service quality on word of mouth, so we can formulate hypothesis as follows:

*H2: There is the effect of e-service quality on word of mouth on online application users.*

Previous research conducted by researchers, including Wasim et al. (2017) also Kyungwan Kang & Chung (2018) said that there was an effect of e-service quality on purchase intention, so we can formulate the following hypothesis:

*H3: There is an influence of e-service quality on purchase intention on online application users.*

Some of the results of research conducted by researchers, including Anggraeni & Rachmanita (2015) also Sta et al. (2018) said that there was an influence of brand love on word of mouth, so the research hypothesis could be formulated as follows:

*H4: There is an influence of brand love on word of mouth on online application users.*

If we look at some of the results of previous studies, among others those conducted by Cristina et al. (2018) and Danish et al. (2018) said that there is an influence of brand love on purchase intention, so that the research hypothesis can be formulated as following:

*H5: There is an influence of brand love on purchase intention on online application users.*

Previous research conducted by researchers, including Shidqi et al. (2019) Also Jalilvand & Samiei (2017) and other researchers Zarei & Kazemi (2014) said that there was an effect of word of mouth on purchase intention, so the research hypothesis can be formulated as follows:

*H6: There is an effect of word of mouth on purchase intention on online application users.*

## **METHODOLOGY**

### **Research Design**

This research refers to research conducted by Sallam (2014) as the main journal and Wasim et al. (2017) as a supporting journal. The research method used is hypothesis testing which is a decision making method using experimental data where the hypothesis testing is an action in statistics to test a assumptions about population parameters according to Sun et al. (2014). This study was conducted to obtain an overview of the effect of e-service quality towards word of mouth that has an impact on purchase intention through brand love for (Product X) online application users. The measurement of the variables in this study uses one measurement method to test indicators for e-service quality, brand love, word of mouth and purchase intention by using a 5-point Likert scale measurement where 1=strongly disagree, 2=disagree, 3=neutral, 4=agree, and 5=strongly agree.

### **Subjects and Procedures**

The sampling method used in this study is non probability sampling, where sampling is based on certain considerations that are in accordance with research needs according to Sekaran

& Bougie. (2013). Determination of the sample using judgment sampling method in purposive sampling that is choosing the most appropriate respondent to be able to determine the information needed. The total population will be 150 respondents which are (Product X) consumers in the vicinity of area Jakarta and other (Product X) consumers who are in forums such as Facebook, Twitter and Instagram, which will be given questionnaires through hardcopy and electronic media such as Google Form.

Data collection in this study uses primary data obtained by survey, based on the population and samples that are available the survey will be carried out by distributing questionnaires. The questionnaire will then be distributed to 150 respondents to be answered. According to Hermawan & Kristaung. (2014) in structural equation modeling a sample size between 100 and 200 is needed. Where the criteria of respondents needed are respondents who have at least 20 years of age or already have their own income and also have used or know about online applications to find needs household. Because of the limited time, funds and energy, this study uses a sample of the population in Table 1 and Table 2.

0	Respondent Characteristics	Amount	Percentage
1.	Gender		
	Male	44	34.4
	Female	84	65.6
	Total	128	100.0
2.	Age		
	20 - 24 years	37	28.9
	25 - 29 years	57	44.5
	26 - 34 years	11	8.6
	35 - 40 years	4	3.1
	> 40 years	19	14.8
	Total	128	100.0
3.	Profession		
	Collage Student	19	14.8
	Employee	78	60.9
	Housewife	5	3.9
	Entrepreneur	15	11.7
	Lecturer	6	4.7
	Civil Servants	5	3.9
	Total	128	100.0
4.	The intensity of using an online application to find household furniture needs for one month.		
	less than 3 times	88	68.8
	3 – 5 times	17	13.3
	More than 5 times	23	18.0
	Total	128	100.0
5.	Expenditures in one month for household furniture needs.		
	< Rp. 1,500,000	94	73.7
	Rp. 1,500,000 - Rp. 3,000,000	22	17.2
	Rp. 3,000,000 – Rp. 5,000,000	5	3.9
	Rp. 5,000,000 - Rp. 10,000,000	7	5.5
	Total	128	100.0

Source: Questionnaire Processed Data 2018



## RESULTS AND FINDINGS

### Validity and Reliability test

Variable	Item	Significant	Information	C.R	Information
E-Service Quality	1	0,815	Valid	0.8996	Reliable
	2	0,794	Valid		
	3	0,815	Valid		
	4	0,747	Valid		
	5	0,833	Valid		
Brand Love	1	0,827	Valid	0.8799	Reliable
	2	0,814	Valid		
	3	0,822	Valid		
	4	0,753	Valid		
Word of Mouth	1	0,799	Valid	0.8328	Reliable
	2	0,813	Valid		
	3	0,856	Valid		
Purchase Intention	1	0,815	Valid	0.8389	Reliable
	2	0,744	Valid		
	3	0,829	Valid		

Source: Primary Data processed, 2018

In accordance with the model developed in this research, the data analysis tool used is Structural Equation Modeling in Figure 1. SEM is used in testing the effect of e-service quality on word of mouth which has an impact on purchase intention through brand love for users of the (Brand “X”) online application which will be operated using AMOS version 22 software.

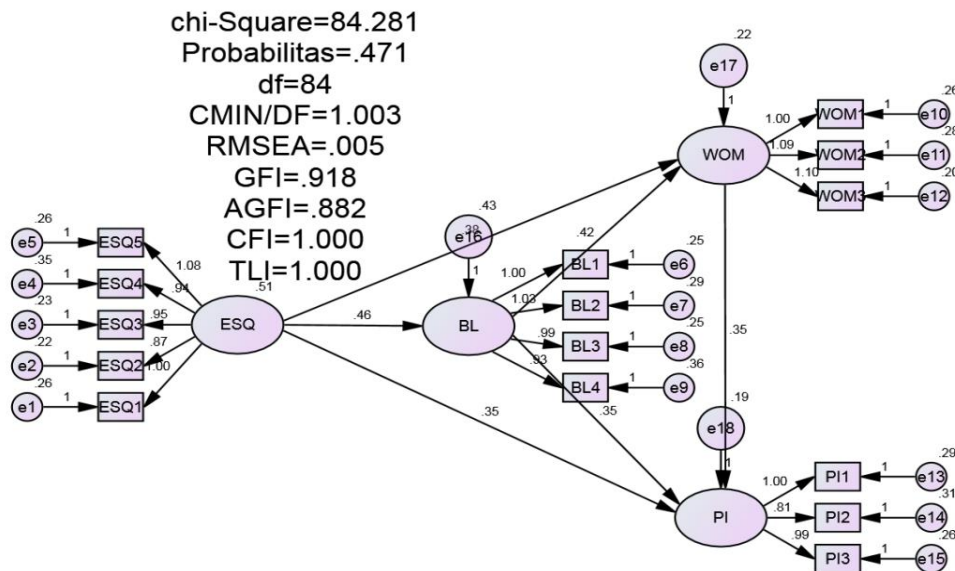

**FIGURE 1**  
**STRUCTURAL EQUATION DIAGRAM**

Normality test is done by using z value (critical ratio or C.R at AMOS output 22.0) from the value of skewness and kurtosis of data distribution. The critical value is  $\pm 2.58$  at a significant level of 0.01 according to (Ghozali, 2011). The results of the data normality test can be done in the following normality test Table 3:

Variable	min	max	skew	c.r.	kurtosis	c.r.
PI3	1.000	5.000	-0.308	-1.420	-0.386	-0.892
PI2	1.000	5.000	-0.398	-1.839	0.102	0.234
PI1	1.000	5.000	-0.227	-1.050	-0.586	-1.352
WOM3	1.000	5.000	-0.575	-2.657	0.108	0.250
WOM2	1.000	5.000	-0.686	-3.169	0.027	0.063
WOM1	1.000	5.000	-0.993	-4.586	1.448	3.344
BL4	1.000	5.000	-0.446	-2.059	-0.023	-0.054
BL3	1.000	5.000	-0.308	-1.424	0.057	0.132
BL2	1.000	5.000	-0.286	-1.320	-0.525	-1.211
BL1	1.000	5.000	-0.625	-2.889	0.405	0.935
ESQ5	1.000	5.000	-0.296	-1.366	-0.501	-1.157
ESQ4	1.000	5.000	-0.205	-0.946	-0.390	-0.901
ESQ3	1.000	5.000	-0.437	-2.021	0.079	0.181
ESQ2	1.000	5.000	-0.501	-2.315	0.586	1.354
ESQ1	1.000	5.000	-0.381	-1.758	0.119	0.274
Multivariate					3.850	0.964

Source Table: AMOS 22 Processed Data

Variable	N	Minimum	Maximum	Mean	Std. Deviation
<b>E - Service Quality</b>					
ESQ1	128	1	5	3.84	0.876
ESQ2	128	1	5	3.84	0.781
ESQ3	128	1	5	3.92	0.829
ESQ4	128	1	5	3.63	0.895
ESQ5	128	1	5	3.77	0.926
Valid N (listwise)	128				
<b>Brand Love</b>					
BL1	128	1	5	3.80	0.888
BL2	128	1	5	3.74	0.933
BL3	128	1	5	3.74	0.881
BL4	128	1	5	3.65	0.910
Valid N (listwise)	128				
<b>Word of Mouth</b>					
WOM1	128	1	5	3.95	0.850
WOM2	128	1	5	3.97	0.913
WOM3	128	1	5	3.89	0.872
Valid N (listwise)	128				
<b>Purchase Intention</b>					
PI1	128	1	5	3.74	0.933
PI2	128	1	5	3.78	0.832



	PI3	128	1	5	3.70	0.910
	Valid N (listwise)	128				

Source: SPSS 21 Processed Data

Based on the Table 4 about the results of the normality test shows that univariate majority are normally distributed because the value of the critical ratio (c.r) for kurtosis (shriveling) and skewness, is in the range of -2.58 to +2.58. While multivariate data fulfills normal assumptions because the value of 0.964 is in the range of ± 2.58.

The statistical results of the variables studied are the dimensions of e-service quality, brand love, word of mouth, and purchase intention.

Hypothesis testing is done to answer the questions in this study or analyze the relationships of structural models. Analysis of hypothesis data can be seen from the value of standardized regression weight which shows the coefficient of influence between variables in the following Table 5:

			Estimate	S.E.	C.R.	P	Conclusion
E-Service Quality	→	Brand Love	.459	.101	4.527	.000	Hypothesis Accepted
E-Service Quality	→	Word of Mouth	.382	.091	4.214	.000	Hypothesis Accepted
E-Service Quality	→	Purchase Intention	.349	.104	3.339	.000	Hypothesis Accepted
Brand Love	→	Word of Mouth	.417	.092	4.540	.000	Hypothesis Accepted
Brand Love	→	Purchase Intention	.346	.108	3.207	.001	Hypothesis Accepted
Word of Mouth	→	Purchase Intention	.353	.133	2.665	.008	Hypothesis Accepted

Source: AMOS 22 Processed Data

### Hypothesis 1

This hypothesis examines the effect of e-service quality on brand love where the relationship between the two variables shows a probability value of 0,000 ( $p < 0.05$ ), so that (H1) reads "*There is an influence between e-service quality on brand love for application users (Brand "X") online*". supported. In addition, the estimated parameter of the standardized regression weight coefficient obtained is 0.459 and the value of C.R 4.527, this indicates that the e-service quality relationship with brand love is positive. This means that the better the quality of services in the field of electronics such as display quality in the online application presented by (Brand "X"), then the information provided through the application is also more complete, the love of consumers or customers for (Brand "X") products is also higher.

This is indicated by the respondents who are (Brand "X") consumers or customers when the content presented by (Brand "X") goes through the application such as the (Brand "X") Catalog, (Brand "X") Store, and on the (Brand "X").co.id site, it becomes more informative so respondents will feel satisfied and happy about the (Brand "X") products they or in other words,

respondents who are interested in (Brand “X”) products will be increasingly facilitated by their desire to have a variety of (Brand “X”) products through the (Brand “X”) online application.

## **Hypothesis 2**

This hypothesis examines the effect of e-service quality on word of mouth where the relationship between the two variables shows a probability value of 0,000 ( $p < 0.05$ ), so that (H2) reads "*There is an influence between e-service quality on word of mouth on users of the (Brand “X”) online application*" supported. In addition, the estimated parameter of the standardized regression weight coefficient obtained is 0.382 and the value of C.R 4.214 shows that the relationship of e-service quality with word of mouth is positive. This means that the more the need for household furniture can be fulfilled through (Brand “X”) online applications and consumers also feel more secure and comfortable when transacting through the application, the greater the possibility of consumers to tell stories and provide positive information about their experiences using (Brand “X”) products to others.

This hypothesis is indicated by the respondents who are (Brand “X”) consumers where in using existing online applications, respondents can search for and get information on products that match what they need, plus when the respondent really wants a product to be purchased, then through the existing application respondents can transact without the need to worry if data or transaction processes are not operating properly so that through their positive experience in shopping for (Brand “X”) products through applications, respondents will tell others, especially those closest to, and make (Brand “X”) products a recommendation when someone asks about household furniture.

## **Hypothesis 3**

This hypothesis examines the effect of e-service quality on purchase intention where the relationship between the two variables shows a probability value of 0,000 ( $p < 0.05$ ), so that (H3) says "*There is an influence between e-service quality on purchase intention on application users (Brand “X”) online*" supported. In addition, the estimated parameter of the standardized regression weight coefficient obtained is 0.349 and the value of C.R 3.339, this indicates that the e-service quality relationship with positive purchase intention. This means that the easier consumers are to access (Brand “X”) online applications and also the more responsive customer service from (Brand “X”) in overcoming the constraints of operating existing applications, the higher the interest of consumers to buy products from (Brand “X”).

Respondents who are (Brand “X”) customers or customers show that, where in the operation of the (Brand “X”) online application they get information on household furniture that is in accordance with what is needed easily and very minimal error in the application, because existing online applications are periodically updated or updated to reduce operating constraints. However, if there are still obstacles in operation, (Brand “X”), in this case the existing customer service, will always help consumers, so that respondents can safely and comfortably use the (Brand “X”) online application.

## **Hypothesis 4**

This hypothesis examines the effect of brand love on word of mouth where the relationship between the two variables shows a probability value of 0,000 ( $p < 0.05$ ), so that (H4) says "*There*



*is an influence between brand love for word of mouth on (Brand "X") online application users supported*". In addition, the estimated parameter of the standardized regression weight coefficient obtained is 0.417 and the value of C.R 4.540, this shows that the relationship between brand love and word of mouth is positive. This means that the more consumers feel happy, happy and proud of the product with the (Brand "X") brand, the greater the possibility of consumers to provide good recommendations for their experience using (Brand "X") products to others.

This is indicated by respondents who are (Brand "X") consumers where respondents who always want to buy products with the (Brand "X") brand or when they need a piece of household furniture and instead buy only products with the (Brand "X") brand will make the respondent talk about positive things for (Brand "X") products to others, about what makes (Brand "X") products their choice and of course makes (Brand "X") products the main recommendation when there is a conversation about furniture with other people.

### **Hypothesis 5**

This hypothesis examines the influence of brand love on purchase intention where the relationship between the two variables shows a probability value of 0.001 ( $p < 0.05$ ), so that (H5) says "*There is an influence between brand love for purchase intention on (Brand "X") online application users supported*". In addition, the estimated parameter of the standardized regression weight coefficient obtained is 0.346 and the value of C.R 3.207 shows that the relationship between brand love and intention purchase is positive. This means that the more love for products with the (Brand "X") brand increases, where consumers feel happy and proud, and care for (Brand "X") products well then the desire to buy (Brand "X") products will also be higher.

This hypothesis is shown by respondents who are (Brand "X") consumers or customers where respondents who already love the products with the (Brand "X") brand, and (Brand "X") products that they only want to have, will automatically increase interest in buying (Brand "X") products, because of the purchasing intensity (Brand "X") products by respondents with a love of these products will also be more frequent (Shakeri & Alavi, 2016).

### **Hypothesis 6**

This hypothesis examines the effect of word of mouth on purchase intention where the relationship between the two variables shows a probability value of 0.008 ( $p < 0.05$ ), so that (H6) reads "*There is influence between word of mouth on purchase intention on (Brand "X") online application users supported.*" In addition, the estimated parameter of the standardized regression weight coefficient obtained is 0.353 and the value of C.R 2.665, this indicates that the relationship of word of mouth and intention purchase is positive. This means that more customers are telling the advantages of (Brand "X") products and giving positive suggestions for (Brand "X") products, so that consumers or prospective consumers buy interest that might have been searching for information (Hair et al., 1998).

The respondents who in this case are (Brand "X") consumers show this, where when respondents who have used (Brand "X") products tell the closest people that the products they use are good, then the interest to buy from fellow consumers or other people as potential customers will also increase, because in theory it has been conveyed, it is said that indeed the recommendations of other people especially the closest people will be more trusted than information from advertisements.

## DISCUSSION

The hypothesis in this research can be said as a new finding, where in previous studies, according to Rowley (2006) that e-service quality has an effect on consumer loyalty and according to Fetscherin & Dato-on (2012) brand love also affects consumer loyalty. So that through this research we want to find out the effect of e-service quality on brand love because in previous research both had an influence on consumer loyalty and the results of the study were that this hypothesis was accepted namely e-service quality had an effect on brand love, the results of this research support research conducted by Sundaram et al. (2017) and Al-dweeri (2017) and Mohammed et al. (2016) say that there is an influence of e-service quality on brand love.

The results of this research are consistent with research by Naik & Krishna (2010) where it is concluded that when customers make good perceptions of their services they will get a positive perception, in other words e-service quality will also have a positive word of mouth impact, the results testing this research supports the research conducted by Zeglat et al. (2016) and Ting et al. (2016) also Syahrivar & Ichlas (2018) saying that there is an effect of e-service quality on word of mouth.

This of course increases interest in buying from (Brand "X") respondents, because their need for information on home furnishings can be met through the (Brand "X") online application. The results of this research are consistent with previous studies carried out by Wasim et al. (2017) where in his study explained that e-service quality that has various indicators such as efficiency, fulfillment, reliability, and privacy has a positive influence on purchase intention, the results of research testing supports the research conducted by Wasim et al. (2017) and Kang & Chung (2018) saying that there is an influence of e-service quality on purchase intention.

The results of this research are consistent with Sallam (2014) research that there is an influence between brand love on word of mouth, the more consumers like or love a brand, the consumer will positively convey all information related to the brand, the results of this research support research conducted by Anggraeni & Rachmanita (2015) and Sta et al. (2018) said that there was an influence of brand love on word of mouth.

The results of this research are consistent with Albert & Merunka (2013) research which shows that brand love has a positive relationship with a consumer's purchase intention, where when a consumer who has a brand will tend to have a sense of desire and the need to have a high product because of his love towards a brand, the results of testing this research support the research conducted by Shidqi et al. (2019), Jalilvand & Samiei (2017) and other researchers Zarei and Kazemi (2014) saying there is an effect of word of mouth on purchase intention.

The results of this research are consistent with Sallam (2014) research conducted previously where it was stated that WOM had an influence on purchase intention. In addition, it is also in line with research conducted by Heriyati & Siek (2011) which states that products that are often referred to in a consumer's conversation tend to lead to stronger purchase intention and give rise to a desire to have a higher level of consumer, the results of testing this research supports the research conducted by Shidqi et al. (2019), Jalilvand & Samiei (2017) and other researchers Zarei & Kazemi (2014) saying there is an effect of word of mouth on purchase intention.



## CONCLUSION

The conclusions of this research, they are: (1). E-service quality has a positive effect on brand love. The quality of service through electronic media provided by (Brand “X”) through its online application makes consumers feel satisfied, happy and proud of their (Brand “X”) products, because the content presented through this online application provides information needed by consumers regarding their needs for home furnishings; (2). E-service quality has a positive effect on word of mouth. (Brand “X”) through its online application such as (Brand “X”) Store, (Brand “X”) Catalog, and the (Brand “X”).co.id site presents an attractive and very easy display to find information related to the products needed to make consumers interested in it and then tell the closest people about their experiences with (Brand “X”) products; (3). E-service quality has a positive effect on purchase intention. The online application which is a wrong way for (Brand “X”) to provide the best quality service in the electronics sector has made consumers' buying interest in (Brand “X”) products increase because what (Brand “X”) provides in its application can make consumers' needs for household furniture fulfilled, consumers do not need to flock to stores (Brand “X”) is to just look for information or even buy a product, because it can be facilitated all through the (Brand “X”) online application; (4). Brand love has a positive effect on word of mouth. This love for (Brand “X”) brand products makes consumers consciously or not promote products from (Brand “X”) by sharing their positive experiences in using (Brand “X”) products. Customers who are happy, happy and proud of their (Brand “X”) products will provide recommendations; (5). Brand love has a positive effect on purchase intention. When consumers feel happy and proud of the products with the (Brand “X”) brand that they have, they will make buying requests for (Brand “X”) products increase, because in this study it was found that consumers with a love for (Brand “X”) products had more than one (Brand “X”) product, so the intensity of their purchases will increase; (6). Word of mouth has a positive effect on purchase intention. Positive experience from consumers when using the (Brand “X”) online application or when using (Brand “X”) products that are told to others will make buying interest in (Brand “X”) products increase, because other people or prospective customers feel more trust and want to buy (Brand “X”) products when they have received information and recommendations good for (Brand “X”) products (James, 1994).

Departing from the conclusions stated above, the results of this study should be used as a reference by (Brand “X”) to further develop its company, especially the quality of its service in the electronic field. (Brand “X”)’s excellent electronic service quality will create a love of products by its customers, and with good quality electronic servants, consumers will tell (Brand “X”) products to the closest people and will increase the demand for purchases from consumers or prospective consumers. This is a part that (Brand “X”) must continue to pay attention to because through good quality electronic services it will provide positive benefits and impacts for the company. In addition, for the (Brand “X”) marketing manager it turns out that through the presentation of a good online application, it is unwittingly a way to market (Brand “X”) and its products very efficiently, because through good electronic services the consumer will tell others about their experiences, and more than that consumers have their own love for (Brand “X”) products and of course buying interest in (Brand “X”) products will also increase. So that (Brand “X”) must continue to maintain and always improve the quality of service, especially in the electronic field (Jean et al., 2001).

This research has been carried out in accordance with existing scientific procedures, but in its implementation there are limitations to the number of respondents who use the (Brand “X”) online application. Apparently in the field there are still many (Brand “X”) consumers who have

not used the (Brand “X”) online application, or have known the (Brand “X”) online application but have never used it. So even though researchers came to the (Brand “X”) store, which in fact many consumers are users of (Brand “X”) products, not all were willing to fill out questionnaires on the grounds that they had never used them.

## REFERENCES

- Albert, N., & Merunka, D. (2013). The role of brand love in consumer brand relationships. *Journal of Consumer Marketing*, 30(3), 258-266.
- Al-dweeri, R.M. (2017). The effect of e-service quality on Jordanian student’s e-loyalty: an empirical study in online retailing”, *Emerald Publishing Limited*. 119(4), 902-923.
- Anggraeni, A., & Rachmanita, R.E. (2015). Effects of brand love, personality and image on word of mouth; the case of local fashion brands among young consumers. Second Global Conference on Business and Social Science, 2015, GCBSS 2015, 17-18 September 2015.
- Belch, G.E. (2004). *Advertising and promotion: an integrated marketing communications perspective*, sixth edition, The McGraw Hill/Irwin: New York.
- Bressolles, G., & Durrieu, F. (2011). Service quality, customer value and satisfaction relationship revisited for online wine websites. In *6th AWBR International Conference*. France.
- Carroll, B.A., & Ahuvia, A.C. (2006). Some antecedents and outcomes of brand love”, *Marketing Letters*, 17(2), 79-90.
- Chase, R.B., Jacobs, F.R., & Aquilano, N.J. (2006). *Operations management for competitive advantage*, 9th ed. New York : McGraw-Hill.
- Cristina, M., Gómez, O., & Pérez, W.G. (2018). effects of brand love and brand equity on repurchase intentions of young consumers”, *International Review of Management and Marketing*, 4, 2018.
- Danish, R.Q., Khan, M.K., Ghafoor, M.M., Ahmad, I., Humayon, A.A., & Aslam, S. (2018). Impact of brand loyalty in assessing purchase intentions of a customer: a study of automobile industry in south asian perspective. *A Research Journal of South Asian Studies*, 33, 347-364.
- Fetscherin, M., & Dato-on, C.M. (2012). brandlove: investigating two alternative love relationships, in Fournier, S., Breazeale, M. and Fetscherin, M. (Eds), *Consumer Brand Relationships: Theory and Practice*, Taylor and Francis, Basingstoke, 151-164
- Fournier, S. (1998). Consumers and their brands: developing relationship theory in consumer research. *Journal of Consumer Research*, 24, 343-373.
- Fournier, S., & Mick, D.G. (1999). Rediscovering Satisfaction. *Journal of Marketing*, 63, 5-23.
- Ghozali, I. (2011). *Aplikasi analisis multivariate dengan program IBM SPSS 19 (V)*. Semarang: Badan Penerbit Universitas Diponegoro.
- Hair, J.F.J., Anderson, R.E., Tatham, R.L., & Black, W.C. (1998). *Multivariate data analysis*, Fifth Edition, Prentice-Hall International, Inc.
- Hasan, Ali. (2010). *Marketing dari mulut ke mulut*. Yogyakarta: Media Pressindo.
- Heriyati, P., & Siek, T.P. (2011). Effects of word of mouth marketing communication and perceived quality on decision making moderated by gender: jakarta blackberry smartphone consumer’s perspective. *Contemporary Management Research*, 7, 329-336.
- Hermawan, A., & Kristaung, R. (2014). *Metodologi Penelitian Bisnis*. Jakarta: Lembaga Penerbit Fakultas Ekonomi Trisakti.
- Ho, C.I., & Lee, Y.L. (2007). The Development of an e-travel service quality scale. *Tourism Management*, 28, 1434-1449.
- Ismail, A.R., & Spinelli, G. (2012). Effects of brand love, personality and image on word of mouth. *Journal of Fashion Marketing and Management: An International Journal*, 16(4), 386-398.
- Jalilvand, M.R., & Samiei, N. (2017). The effect of electronic word of mouth on brand image and purchase intention An empirical study in the automobile industry in Iran, *Marketing Intelligence & Planning*, 30, 460-476, *Emerald Group Publishing Limited*.
- James, F.E. (1994). *Pengertian perilaku konsumen, dalam buku Perilaku Konsumen*, Edisi 6, Jilid 1, Penerbit Bina Rupa Aksara
- Jean, L. Harrison, L., Walker. 2001. The measurement of word of mouth communication and an investigation of service quality and customer commitment as potential antecedents. *Journal of Service Research*.



- Kang, K., & Chung, K. (2018). The effect of e-service quality on brand image and repurchase intention in LCCs: The moderating effect of gender, *Journal of the Korean Data Analysis Society*, 20, 47-58
- Kassim, N., & Abdullah, A.N. (2010). The effect of perceived service quality dimensions on customer satisfaction, trust, and loyalty in e-commerce settings: a cross cultural analysis. *Asia Pacific Journal of Marketing and Logistics*, 22, 351-371.
- Khan, I., Ghauri, T.A., & Majeed, S. (2012). Impact of brand related attributes on purchase intention of customer. a study about the customer of punjab, pakistan. *Interdisciplinary Journal of Contemporary Research in Business*.
- Kotler, P., & Keller, K. (2012). *Marketing Management*. 14th edition. New Jersey: Prentice Hall.
- Mohammed, M.E., Wafik, G.M., Jalil, S.G.A., & El Hassan, Y.A. (2016). The effects of e-service quality dimensions on tourist's e-satisfaction. *International Journal of Hospitality & Tourism Systems*. 9(1) June 2016 ISSN: 0947-6250.
- Naik, C.N., & Krishna. D.K. (2010). Service Quality (Servqual) and its Effect on Customer Satisfaction in Retailing. *European Journal of Social Sciences*. 6(2).
- Parasuraman, A., Zeithmal, V.A & Berry, L.L. (1988), SERVQUAL: A Multiple- item scale for measuring consumer perceptions of service quality. *Journal of Retailing*. 64, 12-14.
- Peter, J.P., & Olson, J.C. (2008). *Consumer Behavior and Marketing Strategy*. 8et editions. Singapore: McGraw-Hill.
- Rowley, J. (2006). *An Analysis of the E-Service Literature: Towards A Research Agenda*. Internet Research. 16, 339-359.
- Sallam, M.A. (2014). The effect of brand image and brand identification on brand love and purchase decision making : The Role of WOM. *Internasional Business Research*. 7, 12-13.
- Santos, J. (2003). *E-Service Quality: A Model of Vistual Service Quality Dimensions Managing Service Quality*, 13 editions.
- Sekaran, U., & Bougie, R. (2013). *Research methods for business: A skillbuilding Approach* (6 ed.). Chichester: Wiley & Sons.
- Shakeri, S., & Alavi, H.H. (2016). Investigating the impact of brand love, brand image, excitement and word of mouth on consumers. *International Journal Of Information Research And Review*, 3, 3081-3085.
- Shidqi, H., Noor, Y.L., & Kirbrandoko. (2019). The Effect of Electronic Word of Mouth on Online trust and Purchase Intention among Millennia's Generation on Instagram, *RJOAS*, 1(85), January 2019 490 DOI 10.18551/rjoas.2019-01.60.
- Sta, N., Abbassi, R., & Elfidha, C. (2018). The effect of brand love on brand performance: the role of brand loyalty. *Journal of Business and Management Research*, 11.
- Sun, Y., Djouni, K.D., Wyk, B.J.V., & Siarry, P. (2014). Hypothesis testing-based adaptive PSO. *Journal of Engineering, Design and Technology*, 12(1) 89-101.
- Sundaram, V., Ramkumar, D., & Shankar P. (2017). Impact of E-Service Quality on Customer Satisfaction and Loyalty Empirical Study in India Online Business, *KINERJA*, 21, 48-69.
- Syahrivar, J., & Ichlas, A.M. (2018). The impact of electronic word of mouth (E-WoM) on brand equity of imported shoes: does a good online brand equity result in high customers' involvements in purchasing decisions?, *The Asian Journal of Technology Management*, 11(1), 57-69.
- Thomson, M., & Park, C.W. (2005). The ties that bind: measuring the strength of consumers emotional attachment to brands. *Journal of Consumer Psychology*, 15(1), 77-91.
- Ting, O.S., Ariff, M.S., Zakuan, N., & Sulaiman, Z. (2016). e-service quality, e-satisfaction and e-loyalty of online shoppers in business to consumer market; evidence form malaysia. MOIME 2016.
- Wasim, A., Hussain, S., Jafar, R.M.S., Latif, W.U. (2017). Impact of E-Service Quality on Purchase Intention Through Mediator Perceived Value in Online Shopping; *Journal of Information Engineering and Applications*, 7(8).
- Zarei, A., & Kazemi, A. (2014). The impact of positive word of mouth on store brand purchase intention with mediated effect of store image and perceived risk towards SBs. *Journal of Accounting & Marketing*, 3(115).
- Zeglat, D., Shrafat F., & Al-Smadi Z. (2016). The impact of the e-service quality of online databases on users' behavioral intentions: a perspective of postgraduate students. *International Review of Management and Marketing*, 6(1), 1-10.