

**PEMBUATAN SERBUK PEWARNA ALAM KAIN DARI EKSTRAK LIMBAH KULIT KOPI ARABIKA (*Coffea arabica*) DENGAN METODE *FOAM-MAT DRYING***  
Muhammad Aziz Husen dan Rizka Amalia

**PEMANFAATAN DAUN KETAPANG SEBAGAI PEWARNA ALAM BATIK DI IKM BATIK BAYAT**  
Sarwono, M. Rudianto, Tiwi Bina Affanti,  
Ratna Endah Santoso, dan Sujadi Rahmad Hidayat

**INNOVATION AND BURDEN SHARING STRATEGY TO INTERNATIONALIZE BATIK: CASE STUDY OF LAWEYAN BATIK**  
Re. Hermini Susiatiningsih, Muhammad Faizal Alfian, and Dewi Setiyaningsih



**COLOR REMOVAL TECHNIQUE (CRT) SEBAGAI ALTERNATIF PENCIPTAAN KARYA BATIK RECYCLE PADA MASA PANDEMI COVID-19**  
Muhammad Arif Jati Purnomo, Sri Marwati, dan Danang Priyanto

**PENGARUH KONSENTRASI SERTA WAKTU PROSES FIKSASI EKSTRAK KAYU JAMBAL (*Phelltophorum pterocarpum*) PEWARNAAN BATIK DITINJAU DARI KETAHANAN LUNTUR DAN KETAJAMAN WARNA**  
Nabila Tria Anggita, Agus Hacrudin, dan Ahmad M Tuadi

**KARYA SENI KREATIF BERKELANJUTAN DENGAN METODE “UPCYCLING CONCEPT”**  
Arif Suharson



**A PRELIMINARY DESIGN OF END EFFECTOR STAMP CANTING FOR BATIK STAMP AUTOMATED PRODUCTION USING DOBOT MAGICIAN ROBOTIC ARM**  
Idriwal Mayusda, Radandio Radix Satriya, Yenni Kristi Manik, Annisa Dewi Akbari,  
Amal Witonohadi, dan Muhammad Ihram Maulana

**KAJIAN BATIK GAMBIR SEBAGAI PRODUK BATIK MINANGKABAU**  
Yuliarma dan Yunisa Ramadhani

**IDENTIFIKASI PENGEMBANGAN USAHA DENGAN PENDEKATAN OVOP PADA PRODUK KERAJINAN BORDIR KABUPATEN MALANG**  
Tin Agustina Karnawati dan Fathorrahman



Akreditasi Dirjen Diktiristek Kemendikbudristek 158/E/KPT/2021

## DINAMIKA KERAJINAN DAN BATIK: MAJALAH ILMIAH

Vol. 41, No. 1, Juni 2024

### **PENANGGUNG JAWAB**

Busi Setiawan, ST, MM (BBSPJIKB)

### **CHIEF EDITOR**

Joni Setiawan, ST, M.Eng (Teknik Material, BBSPJIKB)

### **JOURNAL MANAGER**

Guring Briegel Mandegani, S.Si (Biologi, BBSPJIKB)

### **SEKRETARIS**

Tin Kusuma Arta, S.ST (Teknik Tekstil, BBSPJIKB)

### **SECTION EDITOR**

Joni Setiawan, ST, M.Eng (Teknik Material, BBSPJIKB)

Dana Kurnia Syabana, S.ST (Teknik Tekstil, BBSPJIKB)

Agung Eko Sucahyono, ST, M.MT (Teknik Mesin BBSPJIKB)

Mutiara Triwiswara, ST, M.Sc (Teknik Lingkungan, BBSPJIKB)

I Made Arya Utamaningrat, ST (Teknik Material, BBSPJIKB)

Guring Briegel Mandegani, S.Si (Biologi, BBSPJIKB)

Yudi Satria, S.ST (Teknik Tekstil, BBSPJIKB)

### **COPY EDITOR**

Demas Yogopranoto, ST (Teknik Mesin, BBSPJIKB)

Novita Ekarini, S.ST (Teknik Tekstil, BBSPJIKB)

Imas Arista, ST (Teknik Industri, BBSPJIKB)

Yonathan Raditya, ST (Teknik Industri, BBSPJIKB)

Oky Dwi Kartika Sari, ST (Teknik Industri, BBSPJIKB)

Annisa Rizqi Damayanti, ST (Teknik Industri, BBSPJIKB)

### **LAYOUT EDITOR**

Harnandito Paramadharma, S.Ds (Desain, BBSPJIKB)

Tio Yudha Prasetya, S.Ds (Desain, BBSPJIKB)

Savira Chrissentya Angeli, ST (Teknik Industri, BBSPJIKB)

### **PROOFREADER**

Zohanto Widyantoko, ST, M.Eng (Teknik Elektro, BBSPJIKB)

Kuncup Putih Kusumadhata, S.Ds, MA (Desain, BBSPJIKB)

Majalah Ilmiah Dinamika Kerajinan dan Batik (DKB) terbit dua kali dalam setahun, yaitu bulan Juni dan Desember, sebagai wahana peningkatan apresiasi ilmiah bagi masyarakat dan pejabat fungsional Balai Besar Standardisasi dan Pelayanan Jasa Industri Kerajinan dan Batik DKB berfokus dalam bidang penelitian dan pengembangan kerajinan dan batik dalam aspek bahan baku, perekayasa teknologi, proses produksi, penanganan limbah dan desain. DKB menerima penulisan artikel ilmiah teoritis, laporan kegiatan litbang dan artikel tinjauan di bidang kerajinan dan batik.

**Dinamika Kerajinan dan Batik: Majalah Ilmiah  
diterbitkan oleh:**

Balai Besar Standardisasi dan Pelayanan Jasa  
Industri (BBSPJIKB)  
Kementerian Perindustrian  
Yogyakarta

### **Alamat Redaksi:**

Jl. Kusumanegara No. 7  
Yogyakarta 55166

### **Telepon/Fax:**

(0274)546111/(0274)543582

### **Email:**

redaksi.dkb@gmail.com

Jurnal Online: [ejournal.kemenperin.go.id/dkb](http://ejournal.kemenperin.go.id/dkb)

## DAFTAR ISI



DAFTAR ISI	i
DAFTAR REVIEWER/MITRA BESTARI	ii
PENGANTAR	iii
ABSTRAK	iv - ix
PEMBUATAN SERBUK PEWARNA ALAM KAIN DARI EKSTRAK LIMBAH KULIT KOPI ARABIKA ( <i>Coffee arabica</i> ) DENGAN METODE <i>FOAM-MAT DRYING</i> Muhammad Aziz Husen dan Rizka Amalia	1 - 10
PEMANFAATAN DAUN KETAPANG SEBAGAI PEWARNA ALAM BATIK DI IKM BATIK BAYAT Sarwono, M. Rudianto, Tiwi Bina Affanti, Ratna Endah Santoso, dan Sujadi Rahmad Hidayat	11 - 24
INNOVATION AND BURDEN SHARING STRATEGY TO INTERNATIONALIZE BATIK: CASE STUDY OF LAWEYAN BATIK Rr. Hermini Susiatiningsih, Muhammad Faizal Alfian, and Dewi Setiyaningsih	25 - 38
COLOR REMOVAL TECHNIQUE (CRT) SEBAGAI ALTERNATIF PENCIPTAAN KARYA BATIK RECYCLE PADA MASA PANDEMI COVID-19 Muhammad Arif Jati Purnomo, Sri Marwati, dan Danang Priyanto	39 - 50
PENGARUH KONSENTRASI SERTA WAKTU PROSES FIKSASI EKSTRAK KAYU JAMBAL ( <i>Phelltophorum pterocarpum</i> ) PEWARNAAN BATIK DITINJAU DARI KETAHANAN LUNTUR DAN KETAJAMAN WARNA Nabila Tria Anggita, Agus Haerudin, dan Ahmad M Fuadi	51 - 60
KARYA SENI KREATIF BERKELANJUTAN DENGAN METODE "UPCYCLING CONCEPT" Arif Suharson	61 - 74
A PRELIMINARY DESIGN OF END EFFECTOR STAMP CANTING FOR BATIK STAMP AUTOMATED PRODUCTION USING DOBOT MAGICIAN ROBOTIC ARM Idriwal Mayusda, Radandio Radix Satriya, Yenni Kristi Manik, Annisa Dewi Akbari, Amal Witonohadi, dan Muhammad Ihram Maulana	75 - 88
KAJIAN BATIK GAMBIR SEBAGAI PRODUK BATIK MINANGKABAU Yuliarma dan Yunisa Ramadhani	89 - 102
IDENTIFIKASI PENGEMBANGAN USAHA DENGAN PENDEKATAN OVOP PADA PRODUK KERAJINAN BORDIR KABUPATEN MALANG Tin Agustina Karnawati dan Fathorrahman	103 - 120

## DAFTAR MITRA BESTARI DAN REVIEWER

### MITRA BESTARI

Prof. Dr. M. Dwi Marianto, MFA, Ph.D (Seni Budaya, ISI Yogyakarta)

Dr. Tutik Dwi Wahyuningsih, Ph.D (Kimia, UGM)

Andik Yulianto, ST, MT (Teknik Lingkungan, UII)

M. K. Heliansyah, ST, MT, Ph.D (Teknik Industri, UGM)

Risdiyono, ST, M.Eng, Ph.D (Mesin, UII)

Ida Nuramdhani, S.Si.T, M.Sc (Kimia Tekstil & Zat Warna, STT Tekstil)

Mohamad Widodo, A.T., M. Tech, Ph.D (Teknik Tekstil, STT Tekstil)

Tri Widayatno, ST, M.Sc, Ph. D (Teknik Kimia, UMS)

Dr. rer. nat Nurul Hidayat Aprilita, S.Si, M.Si (Kimia, UGM)

Dr. rer. nat Adhitasari Suratman, S.Si, M.Si (Kimia, UGM)

Sutriyanto, S.Sn, MA (Kriya, ISI Surakarta)

Dr. Eng. R. B. Seno Wulung, ST, MT (Sistem Produksi, Politeknik ATK)

Ir. Isananto Winursito, M.Eng, Ph.D (Teknologi Pertanian, Politeknik ATK)

Dr. Fendi Adiatmono, S.Sn, M.Sn (Kriya, Universitas Kuningan)

Andi Sudiarmo, ST, MT, M.Sc, Ph.D (Teknik Mesin dan Industri, UGM)

Dr. Ir. Retno Widiastuti, MM (Teknologi Hasil Hutan, BBKB)

Unggul Wasiwitono, ST., M.Eng.Sc. (Teknik Mesin, ITS)

Dr. Dani Harmanto BEng (Hons) MSc PhD FHEA PgCert C.Eng MIED AMIMEchE (Industrial Engineering, Uni. of Derby)

Prof. Dr. Ir. Murdijati Gardjito (Batik, PPB Sekarjagad)

Dra. Djangjang Purwo Sedjati, M.Hum. (Kriya Seni, ISI Yogyakarta)

Ir. Dwi Suheryanto, M.Eng (Kimia Tekstil)

Ir. Titiek Pujilestari (Teknologi Pertanian)

Dr. Hanny Hafiar, M.Si (Ilmu Komunikasi, Unpad)

Ir. Radjali Amin, M.App.Sc., Ph.D (Bioengineering, ITY)

Dr. Chandra Tresnadi, M.Ds. (Batik, ITB)

Karsam, MA., Ph.D (Batik, STIKOM Surabaya)

Made Tiartini Mudarahayu, S.Sn., M.Sn (Desain Fashion, ISI Denpasar)

Dr. Dra. Sriti Mayang Sari, M.Sn (Desain Interior, UK Petra)

Dr. Moch. Junaidi Hidayat., ST., M.Ds. (Desain produk, ITAT Surabaya)

Winta Adhitia Guspara, S.T, M.Sn (Desain produk, UKDW)

Verry Andre Fabiani, S.Si, M.Si (Kimia Murni, Universitas Bangka Belitung)

Dr. Muhammad Abdurrahman Munir, M.Sc. (Kimia Murni, Universitas Alma Ata)

Dr. Lucky Wijayanti, S.Sn (Seni Kriya, IKJ)

Siti Afiani Musyarofah, STP, MT (Teknik Industri, Kementrian Perindustrian)

Dr. Ida Kusnawati Tjahjani., S.T., M.T., I.P.M (Teknik Industri, LPM)

Dr. Hana Catur Wahyuni ST.MT (Teknik Industri, UM Sidoarjo)

M. Mujiya Ulkhaq, S.T., M.Sc., Ph.D. (Teknik Industri, Undip)

Fajar Pitarsi Dharma, S.ST., MT. (Teknik Industri, AK-Tekstil Solo)

Aulia Rahma, S.T., M.T (Teknik Kimia, Universitas Lambung Mangkurat)

Dr. Anies Mutiari, S.T, M.Eng (Teknik Kimia, BBSPJIBBT)

Dr. Arlini Dyah Radityaningrum, S.T., M.Eng.Sc. (Teknik Lingkungan, ITAT Surabaya)

Fajar Nugroho, S.T., M.Eng. (Teknik Mesin, ATDA)

Rizqi Ilmal Yaqin, S.T., M.Eng. (Teknik Mesin, Politeknik Kelautan dan Perikanan Dumai)

Nyoman Sugiarta, S.T., M.Eng., M.Si. (Teknik Mesin, Politeknik Negeri Bali)

Yudho Yudhanto S.Kom., M.Kom (Teknologi Informasi, UNS)

Ir. Dahlan Susilo, M.Kom (Teknologi Informasi, Universitas Sahid Surakarta)

Joko Kuswanto, M. Kom (Teknologi Informasi, Universitas Baturaja)

### REVIEWER

Edi Eskak, S.Sn, M.Sn (Kriya, BBSPJIKB)

Masiswo, S.Sn, M.Sn (Batik dan Visual Art, BBSPJIKB)

Istihanah Nurul Eskani, ST, M. Ec. Dev (Teknik Kimia, BBSPJIKB)

Isnaini, ST, MT (Teknik Industri, BBSPJIKB)

Agus Haerudin, ST, MT ((Teknik Industri, BBSPJIKB)

Irfa ina Rohana Salma, S.ST, M.Sn (Kimia Tekstil dan Kriya, BBSPJIKB)

Vivin Atika, ST, M.Eng (Teknik Kimia, BBSPJIKB)

## PENGANTAR

Puji syukur kami panjatkan ke hadirat Tuhan YME sehingga penyusunan Majalah Ilmiah Dinamika Kerajinan dan Batik (DKB) Volume 41, No.1, Juni 2024 dapat terwujud dengan baik.

Terbitan kali ini tetap menampilkan 9 (sembilan) naskah yang terdiri dari 7 (tujuh) naskah berbahasa Indonesia dan 2 (dua) naskah berbahasa Inggris.

Kami mengucapkan terimakasih kepada para penulis naskah, editor, section editor, layout editor dan proofreader serta seluruh pihak yang mendukung terbitnya Majalah Ilmiah Dinamika Kerajinan dan Batik (DKB) Volume 41, No.1, Juni 2024. Semoga majalah ilmiah ini tetap menjadi sumber referensi yang dapat mendukung perkembangan industri batik dan kerajinan di Indonesia.

*Redaksi*

## DINAMIKA KERAJINAN DAN BATIK: MAJALAH ILMIAH

P-ISSN 2087-4294

E-ISSN 2528-6196

### ABSTRAK

Volume. 41, No.1 Juni 2024

DDC: 677; 667.2

Muhammad Aziz Husen dan Rizka Amalia  
Teknologi Rekayasa Kimia Industri, Sekolah Vokasi,  
Universitas Diponegoro  
email: amaliarizka@live.undip.ac.id

#### PEMBUATAN SERBUK PEWARNA ALAM KAIN DARI EKSTRAK LIMBAH KULIT KOPI ARABIKA (*Coffea arabica*) DENGAN METODE FOAM-MAT DRYING

Dinamika Kerajinan dan Batik: Majalah Ilmiah. Juni 2024, Vol. 41. No. 1, Hal: 1 - 10

Indonesia merupakan salah satu penghasil kopi terbesar di dunia dimana kopi menjadi komoditas nomor urut kedua paling banyak diperjualbelikan di dunia. Hal ini menyebabkan limbah kulit kopi arabika melimpah, sehingga dapat dimanfaatkan lebih lanjut, salah satunya adalah sebagai pewarna alam. Pewarna alam dalam sediaan cair telah banyak digunakan, namun demikian pewarna tersebut memiliki kekurangan antara lain proses yang tidak praktis dan masa simpan sediaan cair yang singkat. Tujuan penelitian ini adalah untuk mempelajari proses pembuatan serbuk pewarna dari limbah kulit kopi menggunakan metode foam-mat drying dengan mengkaji penambahan maltodekstrin, putih telur dan variasi suhu pengering terhadap kualitas serbuk warna alam yang dihasilkan. Metode foam-mat drying merupakan teknik pengeringan dengan bahan berbentuk cair menggunakan cara pembusaan dimana ditambahkan foam stabilizer pada suhu rendah. Hasil penelitian pembuatan serbuk warna alam kulit kopi terbaik diperoleh pada konsentrasi maltodekstrin 10%, putih telur 25% serta suhu pengering sebesar 80°C dimana didapatkan serbuk dengan rendemen 12,036 %, kadar air 5,20%, intensitas cahaya dengan L\*(kecerahan) 16,25, a\*(hijau-merah) 14,55 dan b\*(biru-kuning) 17,69.

**Kata Kunci:** kulit kopi arabika, ekstraksi, serbuk warna alam, foam-mat drying

DDC: 658; 338

Sarwono, M. Rudianto, Tiwi Bina Affanti, Ratna Endah Santoso, dan Sujadi Rahmad Hidayat  
Fakultas Seni Rupa dan Desain, Universitas Sebelas Maret, Jl. Ir. Sutami 36A Surakarta, 57126, Indonesia  
email: mrudiantomsn@staff.uns.ac.id

#### PEMANFAATAN DAUN KETAPANG SEBAGAI PEWARNA ALAM BATIK DI IKM BATIK BAYAT

Dinamika Kerajinan dan Batik: Majalah Ilmiah. Juni 2024, Vol. 41. No. 1, Hal: 11 - 24

Usaha batik warna alam di Daerah Bayat Klaten terdapat terkendala terkait harga bahan baku, sehingga memengaruhi penetapan harga jual produk. Penelitian diharapkan dapat merekomendasikan alternatif bahan baku warna alam sebagai substitusi pewarna batik. Tumbuhan yang umum dijumpai di daerah setempat adalah pohon ketapang (*Terminalia catappa*). Pohon ketapang dimanfaatkan sebagai tanaman penghias atau tanaman peneduh yang banyak tumbuh di negara-negara tropis. Penelitian bertujuan untuk memanfaatkan daun ketapang sebagai bahan pewarna alam ramah lingkungan untuk memperoleh alternatif bahan dan keterjangkauan harga.

Menggunakan metode eksperimen dengan pendekatan kualitatif deskriptif. Penelitian dilakukan pada perajin batik warna alam di daerah Bayat Klaten. Sampel penelitian adalah daun ketapang secara random sampling yang terbagi menjadi dua jenis yaitu daun ketapang berwarna hijau dan daun ketapang berwarna kemerahan. Penelitian diterapkan pada proses produksi batik cap, dengan proses penelitian meliputi tahapan mordanting; pengecapan; ekstraksi warna; penguncian warna dengan tunjung, kapur dan tawas. Dilakukan pengujian ketahanan warna terhadap pencucian, yang hasilnya dapat direkomendasikan untuk proses produksi batik. Hasil ekstraksi daun ketapang yang diterapkan pada kain batik menghasilkan pewarna yang mengarah ke warna kecoklatan. Daun ketapang dapat menjadi alternatif warna alam berdasarkan penggunaan daun yang dipilih serta dipengaruhi oleh bahan pengunci yang digunakan.

**Kata Kunci:** pemulihan usaha, pewarna alam, ketapang

DDC: 306,4

Rr. Hermi Susiatiningsih, Muhammad Faizal Alfian, and Dewi Setiyaningsih  
Program Studi Hubungan Internasional, Fakultas Ilmu Sosial dan Politik, Universitas Diponegoro, Indonesia.  
email: [herminisusi@lecturer.undip.ac.id](mailto:herminisusi@lecturer.undip.ac.id),  
[muhhammadfaizalalfian@lecturer.undip.ac.id](mailto:muhhammadfaizalalfian@lecturer.undip.ac.id),  
[dwsetyajoikromo@gmail.com](mailto:dwsetyajoikromo@gmail.com)

#### INOVASI DAN STRATEGI BAGI BEBAN UNTUK INTERNASIONALISASI BATIK: STUDI KASUS PADA BATIK LAWEYAN

Dinamika Kerajinan dan Batik: Majalah Ilmiah. Juni 2024, Vol. 41. No. 1, Hal: 25 - 38

Sebagai warisan budaya, Batik memiliki nilai tambah ekonomi yang membuatnya dapat dipasarkan di tingkat domestik dan internasional. Manfaat paling signifikan dari promosi produk batik ke pasar global adalah membawa nilai-nilai lokal ke masyarakat global, serta manfaat pembangunan ekonomi bagi industri garmen dalam negeri. Laweyan merupakan salah satu kabupaten di Solo yang mengkhususkan diri dalam produksi kain batik. Industri di Laweyan memproduksi kain batik lukis dan cetak yang didistribusikan tidak hanya di pasar lokal tetapi juga di pasar global. Dengan menggunakan metode kualitatif, penelitian ini menganalisis inovasi produk batik di Laweyan dan inovasi marketing Batik Laweyan dalam menembus pasar global. Temuan dari riset ini menyimpulkan bahwa produsen di Kabupaten Laweyan mengembangkan inovasi produk berupa penyesuaian motif batik bernuansa lokal dengan selera pasar internasional, dan untuk mendorong internasionalisasi, produsen menggunakan inovasi pemasaran melalui strategi burden sharing. Maka, dalam hal internasionalisasi, nilai-nilai budaya lokal menjadi aspek penting dalam inovasi produk, sedangkan dalam hal pemasaran, strategi burden sharing menjadi inovasi dalam upaya menembus pasar internasional. Melalui strategi burden sharing, produsen lokal membangun jejaring dengan produsen luar negeri untuk memperoleh permintaan dari pasar luar negeri, sehingga produsen lokal dapat menjangkau pasar dunia dengan menjembatani antara industri lokal dan pasar internasional.

**Kata Kunci:** komoditas batik, kewirausahaan, strategi bisnis,

## DINAMIKA KERAJINAN DAN BATIK: MAJALAH ILMIAH

P-ISSN 2087-4294

E-ISSN 2528-6196

### ABSTRAK

Volume. 41, No.1 Juni 2024

internasionalisasi pasar.

DDC: 628

Muhammad Arif Jati Purnomo, Sri Marwati, dan Danang Priyanto

Fakultas Seni Rupa dan Desain, Institut Seni Indonesia Surakarta

email: [danangpriyanto515@gmail.com](mailto:danangpriyanto515@gmail.com),

[ariefj4ti@gmail.com](mailto:ariefj4ti@gmail.com), [art.marwatie@gmail.com](mailto:art.marwatie@gmail.com)

#### **COLOR REMOVAL TECHNIQUE (CRT) SEBAGAI ALTERNATIF PENCIPTAAN KARYA BATIK RECYCLE PADA MASA PANDEMI COVID-19**

Dinamika Kerajinan dan Batik: Majalah Ilmiah. Juni 2024, Vol. 41 No. 1, Hal: 39 - 50

Corona Virus Disease-19 (Covid-19) adalah jenis penyakit menular yang disebabkan oleh virus Corona yang baru ditemukan dan status perkembangannya sangat cepat hingga termasuk dalam jenis virus bersifat pandemi. Fenomena pandemi Covid-19, yang mengharuskan untuk bekerja dari rumah atau Work From Home (WFH) menginspirasi untuk meredesain kembali produk tekstil lama termasuk batik untuk direcycle dengan tampilan motif yang baru. Color Removal Technique (CRT) adalah teknik pencabutan warna atau pelunturan warna pada desain tekstil permukaan atau surface design. Penelitian artistik ini bertujuan mengidentifikasi material bahan yang bisa digunakan sebagai alternatif dalam pemanfaatan batik recycle; dan menciptakan desain motif batik dengan Color Removal Technique (CRT) dari sebuah fenomena wabah Covid-19. Metode yang digunakan melalui tahapan eksplorasi, eksperimentasi, perenungan, perancangan dan perwujudan. Luaran dari penelitian ini berupa 5 buah karya yang terdiri dari 2 buah karya yang berfungsi dekoratif dan 3 buah baju yang didaftarkan Hak Kekayaan Intelektual (HKI), serta artikel ilmiah yang dimuat dalam jurnal ilmiah nasional. Penelitian ini sebagai alternatif metode perwujudan karya mode dengan memanfaatkan limbah tekstil yang gagal produksi sehingga meminimalkan dampak pencemaran lingkungan oleh sampah.

**Kata Kunci:** pandemi Covid-19, teknik pelunturan warna, batik daur ulang

DDC:677;667

Nabila Tria Anggita<sup>1</sup>, Agus Haerudin<sup>2</sup>, dan Ahmad M Fuadi<sup>1</sup>

<sup>1</sup>Universitas Muhammadiyah Surakarta, Jl. Ahmad Yani, Pabelan, Kartasura, Indonesia

<sup>2</sup>Balai Besar Kerajinan dan Batik, Jl. Kusumanegara, No. 7

Yogyakarta, Indonesia

email: [d500190052@student.ums.ac.id](mailto:d500190052@student.ums.ac.id)

#### **PENGARUH KONSENTRASI SERTA WAKTU PROSES FIKSASI EKSTRAK KAYU JAMBAL (*Pheltophorum pterocarpum*) PEWARNAAN BATIK DITINJAU DARI KETAHANAN LUNTUR DAN KETAJAMAN WARNA**

Dinamika Kerajinan dan Batik: Majalah Ilmiah. Juni 2024, Vol. 41. No. 1, Hal: 51 - 60

Kain batik diwarnai dengan pewarna alami dan pewarna

sintesis. Pewarna sintesis mempunyai keunggulan yaitu: warna yang beragam, dijamin kecerahan warnanya, stabil, tidak mudah luntur, tahan diberbagai kondisi lingkungan, memiliki kekuatan warna yang baik, mudah didapatkan, harganya ekonomis. Namun, penggunaan pewarna sintetis pada kehidupan sehari-hari menimbulkan dampak buruk terhadap lingkungan karena sifatnya yang karsinogenik. Sehingga, perlu upaya guna menghasilkan pewarna alami pengganti sintetis. Kulit kayu jambal berpotensi sebagai pewarna alami karena mengandung (+)-leucocyanidin-3-O-@-D-galactopyranoside. Penelitian ini memakai kulit kayu jambal dengan pengaruh jenis konsentrasi dan waktu proses fiksasi dengan konsentrasi 20, 50, 70 dan 90 g/L dari hasil penelitian yang dilakukan guna mengetahui kelayakan dari bahan alami Kulit Kayu Jambal (*Peltophorum Pterocarpum*) dilakukannya penelitian dengan uji luntur warna kain dan L\*a\*b\* nilai yang dihasilkan digunakan untuk diuji pencucian menggunakan sabun (kelunturan) mendapatkan nilai 4-5.

**Kata Kunci:** Pewarna alami, kulit kayu jambal, tahan luntur warna, fiksasi

DDC: 746.662

Arif Suharson

Jurusan Kriya, Fakultas Seni Rupa, Institut Seni Indonesia Yogyakarta

email: [arifshuharson318@gmail.com](mailto:arifshuharson318@gmail.com)

#### **KARYA SENI KREATIF BERKELANJUTAN DENGAN METODE "UPCYCLING CONCEPT"**

Dinamika Kerajinan dan Batik: Majalah Ilmiah. Juni 2024, Vol. 41 No. 1, Hal: 61 -74

Kemajuan teknologi dalam kehidupan manusia berdampak pada meningkatnya kebutuhan produk-produk atau komponen mesin yang diterapkan pada hasil karya terbarukan. Tuntutan kebutuhan manusia untuk memenuhi desain terbaru, teknologi tepat guna atau tren desain, atau alasan lainnya meninggalkan produk atau komponen yang dahulu dianggap baru menjadi usang bahkan berubah menjadi sampah atau limbah. Tujuan penelitian untuk memahami upcycling concept sebagai metode bagi insan kreatif dunia seni rupa untuk mewujudkan karya baru dari produk, komponen atau barang lama menjadi memiliki nilai kebaruan atau menghadirkan keberadaan produk yang telah menjadi sampah atau limbah menjadi karya seni berkelanjutan yang bermanfaat bagi kehidupan manusia di tengah derasnya perubahan dunia teknologi industri. Metode yang digunakan yaitu deskriptif analitis untuk mengkaji karya seni berkelanjutan dari bahan yang tidak terpakai menjadi produk kreatif yang bernilai. Dari kajian ini dihasilkan bahwa eksperimen yang dilakukan oleh seniman didukung dengan metode practice-based research untuk mencapai kreasi artistik melahirkan seni kreatif berkelanjutan dapat diwujudkan. Produk yang tercipta dari metode upcycling concept berupa karya-karya kreatif yang dapat digunakan sebagai elemen estetis interior-eksterior, karya seni, sampai pada produk fungsional praktis yang digunakan sehari-hari.

**Kata Kunci:** seniman, karya seni, keberlanjutan, upcycling concept

## DINAMIKA KERAJINAN DAN BATIK: MAJALAH ILMIAH

P-ISSN 2087-4294

E-ISSN 2528-6196

### ABSTRAK

Volume.41, No.1 Juni 2024

DDC: 745.5

Idriwal Mayusda<sup>1</sup>, Radandio Radix Satriya<sup>1</sup>, Yenni Kristi Manik<sup>1</sup>, Annisa Dewi Akbari<sup>1</sup>, Amal Witonohadi<sup>1</sup>, dan Muhammad Ihram Maulana<sup>2</sup>

<sup>1</sup>Program Studi Teknik Industri, Universitas Trisakti, Jakarta, Indonesia

<sup>2</sup>Program Studi Teknik Mesin, Universitas Trisakti, Jakarta, Indonesia

email: idriwal.mayusda@trisakti.ac.id

#### **PERANCANGAN AWAL *END EFFECTOR* CANTING CAP UNTUK PRODUKSI BATIK CAP TEROTOMASI DENGAN MENGGUNAKAN *ROBOTIC ARM* “*DOBOT MAGICIAN*”**

Dinamika Kerajinan dan Batik: Majalah Ilmiah. Juni 2024, Vol. 41. No. 1, Hal: 75- 88

Keterbatasan sumber daya manusia (SDM) menghambat produksi batik cap di sanggar Batik Kembang Mayang padahal permintaan batik yang tinggi harus dipenuhi oleh sanggar. Penelitian ini bertujuan untuk merancang produksi cap batik terotomasi menggunakan *Robotic Arm* “*The Dobot Magician*” sebagai alternatif untuk memenuhi permintaan tersebut. Perancangan dilakukan dengan menggunakan metode *Quality Functions Deployment* (QFD). Hasil penelitian memberikan 16 alternatif desain alat canting cap berdasarkan interpretasi kebutuhan sanggar Batik Kembang Mayang. Alternatif ini kemudian dianalisis dengan metode *Finite Element Analysis* untuk mendapatkan desain alat canting cap terpilih yang memiliki 13 atribut spesifikasi canting cap. Alat ini menggunakan material polikarbonat yang diproduksi dengan proses *additive manufacturing* atau *3D printing*. Penerapan alat ini pada *Robotic Arm* “*Dobot Magician*” terbukti bisa menghasilkan batik cap.

**Kata Kunci:** otomasi, batik, canting cap, produksi, robotic arm

DDC: 677

Yuliarma dan Yunisa Ramadhani

Universitas Negeri Padang, Padang, Sumatera Barat, 25132, Indonesia

email: yuliarmaincim@yahoo.com

#### **KAJIAN BATIK GAMBIR SEBAGAI PRODUK BATIK MINANGKABAU**

Dinamika Kerajinan dan Batik: Majalah Ilmiah. Juni 2024, Vol. 41 No. 1, Hal: 89-102

Batik merupakan warisan budaya masyarakat Indonesia yang telah mendunia. Setiap daerah memiliki corak batik tersendiri. Bagi pembatik di Sumatera Barat selalu didengar beberapa kesulitan dalam pengembangan motif, yang terkesan monoton dan tidak bervariasi. Pada batik gambir ini terdapat inovasi ciri khas motif yaitu gambir dan kekayaan alam dan budaya daerah Minangkabau. Kebanyakan batik di berbagai daerah memakai pewarna sintesis sebagai pewarnaan batik, sementara batik gambir lebih memilih gambir sebagai bahan baku pewarnaan alam. Tujuan dari penelitian ini adalah untuk mengkaji batik gambir sebagai produk inovatif batik Minangkabau meliputi karakteristik motif dan proses pewarnaan. Metode penelitian

yang digunakan yaitu deskriptif kualitatif dengan sumber data primer: karakteristik motif dan proses pewarnaan dan data sekunder: dokumentasi dan kajian teori. Hasil penelitian ditemukan 1) bentuk motif gambir tigo sarumpun, tari payung, awan berarak, kelok rumah gadang 50 kota, dan rangkiang manjala sebagai motif batik inovatif. Motif ini terinspirasi dari keanekaragaman alam dan kebudayaan Kabupaten Lima Puluh Kota, 2) proses pewarnaan menggunakan zat warna alam dari ekstrak gambir sebagai pewarnaan batik yang inovatif.

**Kata Kunci:** batik gambir, produk inovatif, batik Minangkabau

DDC: 658; 338

Tin Agustina Karnawati dan Fathorrahman

Institut Teknologi dan Bisnis Asia Malang

email: agustina@asia.ac.id

#### **IDENTIFIKASI PENGEMBANGAN USAHA DENGAN PENDEKATAN OVOP PADA PRODUK KERAJINAN BORDIR KABUPATEN MALANG**

Dinamika Kerajinan dan Batik: Majalah Ilmiah. Juni 2024, Vol. 41. No. 1, Hal: 102 - 120

Peningkatan kesejahteraan masyarakat dapat dilakukan dengan pengembangan potensi daerah melalui pemanfaatan potensi sumber daya lokal. Pendekatan *One Village One Product* (OVOP) yang dirancang untuk meningkatkan keunggulan potensi desa, diharapkan mempercepat laju pertumbuhan ekonomi yang mampu meningkatkan kesejahteraan masyarakat. Produk kerajinan bordir merupakan salah satu produk lokal unggulan daerah yang memiliki potensi berkembang. Tujuan penelitian ini mengidentifikasi permasalahan untuk menemukan rumusan model pengembangan usaha dengan pendekatan OVOP pada produk kerajinan bordir di Kabupaten Malang. Jenis penelitian ini menggunakan pendekatan deskriptif kualitatif dan pengumpulan data melalui observasi dan wawancara. Hasil penelitian menunjukkan bahwa permasalahan utama adalah keterbatasan modal, faktor pengetahuan sumber daya manusia, wawasan manajerial dan pemasaran serta relasi bisnis. Pendekatan OVOP pada usulan prototype model pengembangan usaha ini diperlukan pengamatan awal pada 'need assessment' untuk memberikan pembinaan lebih lanjut pada segi manajerial, teknis dan softskill dari pihak pemerintah, akademisi dan praktisi atau pakar yang relevan dengan kebutuhan materi pelatihan.

**Kata Kunci:** pengembangan usaha, produk kerajinan bordir, one village one product (OVOP)



## DINAMIKA KERAJINAN DAN BATIK: MAJALAH ILMIAH

P-ISSN 2087-4294

E-ISSN 2528-6196

### ABSTRACT

Volume. 41, No.1, June 2024

DDC: 677; 667.2

Muhammad Aziz Husen and Rizka Amalia  
Industrial Chemical Engineering, Vocational School Sekolah  
Vokasi, Universitas Diponegoro  
email: amaliarizka@live.undip.ac.id

#### **PRODUCTION OF NATURAL DYE FABRIC POWDER FROM ARABICA COFFEE (COFFEE ARABICA) SKIN WASTE EXTRACT USING FOAM-MAT DRYING**

Dinamika Kerajinan dan Batik: Majalah Ilmiah, June 2024, Vol. 41 No. 1, pages 1 - 10

Indonesia is one of the largest coffee producers in the world, where coffee is the second most traded commodity in the world. This causes Arabica coffee skin waste to become abundant, so that it can be used further, one of which is as a natural dye. Natural dyes in liquid preparations have been widely used, however these dyes have disadvantages including impractical processing and short shelf life of liquid preparations. The aim of this research is to study the process of making coloring powder from coffee skin waste using the foam-mat drying method by examining the addition of maltodextrin, egg white and variations in drying temperature on the quality of the natural colored powder produced. The foam mattress drying method is a drying technique with liquid material using a foaming method where foam stabilizer is added at low temperatures. The results of research on making the best natural coffee skin color powder were obtained at a maltodextrin concentration of 10%, egg white 25% and a drying temperature of 80 0C where powder was obtained with a yield of 12.036%, air content of 5.20%, light intensity with L\* (brightness) 16 .25, a\*(green-red) 14.55 and b\*(blue-yellow) 17.69.

**Keywords:** arabica coffee skin, extraction, natural color powder, foam-mat drying

DDC: 658; 338

Sarwono, M. Rudianto, Tiwi Bina Affanti, Ratna Endah Santoso, and Sujadi Rahmad Hidayat  
Faculty of Art and Design, Universitas Sebelas Maret, Jl. Ir. Sutami 36A Surakarta, 57126, Indonesia  
email: mruantomsn@staff.uns.ac.id

#### **UTILIZATION OF KETAPANG LEAVES AS NATURAL BATIK DYES IN BAYAT'S SMALL AND MEDIUM-SIZED BATIK INDUSTRIES**

Dinamika Kerajinan dan Batik: Majalah Ilmiah, June 2024, Vol. 41, No. 1, pages 11- 24

The natural color batik business in the Bayat area of Klaten is constrained by the price of raw materials, which affects the selling price of the product. The research is expected to recommend alternative natural color raw materials as a substitute for batik dyes. A common plant found in the local area is the ketapang tree (*Terminalia catappa*). The research

aims to utilize ketapang leaves as environmentally friendly natural dyes to obtain alternative materials and affordability. Using an experimental method with a descriptive qualitative approach. The research was conducted on natural color batik crafters in the Bayat area of Klaten. The research sample is ketapang leaves by random sampling which is divided into two types, namely green ketapang leaves and reddish ketapang leaves. The research is applied to the production process of stamped batik, with the research process including the stages of mordanting; tasting; color extraction; color locking with arbor, lime and alum. Testing of color resistance to washing was carried out, the results of which can be recommended for the batik production process. Ketapang leaves can be an alternative to natural colors based on the use of the selected leaves and are influenced by the locking agent used.

**Keywords:** business recovery, natural dyes, ketapang

DDC: 306.4

Rr. Hermini Susiatiningsih, Muhammad Faizal Alfian, and Dewi Setiyaningsih  
Department of International Relations, Faculty of Social Political Science, Univeristas Diponegoro, Indonesia.  
email: [herminisusi@lecturer.undip.ac.id](mailto:herminisusi@lecturer.undip.ac.id),  
[muhammadfaizalalfian@lecturer.undip.ac.id](mailto:muhammadfaizalalfian@lecturer.undip.ac.id),  
[dwsetyajoikromo@gmail.com](mailto:dwsetyajoikromo@gmail.com)

#### **INNOVATION AND BURDEN SHARING STRATEGY TO INTERNATIONALIZE BATIK: CASE STUDY OF LAWEYAN BATIK**

Dinamika Kerajinan dan Batik: Majalah Ilmiah, June 2024, Vol. 41. No. 1, pages 25 - 38

Batik has added economic value as a cultural heritage, making it marketable at domestic and international levels. The most significant benefits of promoting batik products to the global market are bringing local values to global society, as well as the benefits of economic development for the domestic garment industry. Laweyan is one of the Solo districts specializing in batik cloth production. The sector in Laweyan produces painted and printed batik cloth, distributed not only in the local market but also in the global market. By using qualitative methods, this research analyses the innovation of batik products and marketing innovations of Batik Laweyan in penetrating the global market. The findings from this research conclude that producers in Laweyan Regency develop product innovations by adapting batik motifs with local nuances to international market tastes, and to encourage internationalization, producers use marketing innovations through a burden-sharing strategy. So, in terms of internationalization, local cultural values become an essential aspect of product innovation. In contrast, in terms of marketing, the burden-sharing strategy becomes an innovation to penetrate international markets. Through the burden-sharing approach, local producers build networks with foreign producers to obtain demand from foreign markets so that local producers can reach the world market by bridging the local industry and international markets.

## DINAMIKA KERAJINAN DAN BATIK: MAJALAH ILMIAH

P-ISSN 2087-4294

E-ISSN 2528-6196

### ABSTRACT

Volume. 40, No.1, June 2024

**Keywords:** Batik commodity, entrepreneurship, business strategy, market internationalization.

DDC: 628

Muhammad Arif Jati Purnomo, Sri Marwati, and Danang Priyanto

Faculty of Art and Design, Art Institute of Indonesia in Surakarta

email: [danangpriyanto515@gmail.com](mailto:danangpriyanto515@gmail.com),

[ariefj4ti@gmail.com](mailto:ariefj4ti@gmail.com), [art.marwatie@gmail.com](mailto:art.marwatie@gmail.com)

#### COLOR REMOVAL TECHNIQUE (CRT) AS AN ALTERNATIF FOR THE CREATION OF RECYCLE BATIK WORKS DURING THE COVID-19 PANDEMIC

Dinamika Kerajinan dan Batik: Majalah Ilmiah, June 2024, Vol. 41 No. 1, pages 39 - 50

Corona Virus Disease-19 (Covid-19) is a type of infectious disease caused by a newly discovered corona virus and its development status is very fast so that it is included in the type of pandemic virus. One of the impacts is the existence of a government policy to work from home. The phenomenon of the Covid-19 pandemic, which requires working from home or Work From Home (WFH) has inspired to redesign old textile products including batik to be recycled with new motifs. Color Removal Technique is a Color Removal technique or color fading in surface textile designs or surface designs. As for the application of motives with the idea of working, studying and worshipping at home as a form of persuasive communication efforts on batik work so that the public can participate in suppressing the spread of the Covid-19 pandemic. This artistic research aims to (1) identify materials that can be used as alternatives in the use of recycled batik; (2) creating batik motif designs with Color Removal Techniques from a Covid-19 outbreak phenomenon. The method used is through the stages of exploration, experimentation, reflection, design and embodiment. The output of this research is in the form of 5 works consisting of 2 decorative works and 3 clothes that are registered Intellectual Property Right, as well as scientific articles published in national scientific journals. This research is an alternative method for creating fashion creations by utilizing textile waste that has failed in production so as to minimize the impact of environmental pollution by waste.

**Keywords:** Covid-19 pandemic, color removal technique, batik recycle

DDC: 677; 667

Nabila Tria Anggita<sup>1</sup>, Agus Haerudin<sup>2</sup> and Ahmad M Fuadi<sup>1</sup>

<sup>1</sup>Universitas Muhammadiyah Surakarta, Jl. Ahmad Yani, Pabelan, Kartasura, Indonesia

<sup>2</sup>Balai Besar Kerajinan dan Batik, Jl. Kusumanegara, No. 7 Yogyakarta, Indonesia

email: [d500190052@student.ums.ac.id](mailto:d500190052@student.ums.ac.id)

#### EFFECT OF CONCENTRATION AND TIME OF FIXATION PROCESS OF JAMBAL WOOD

#### (*Peltophorum pterocarpum*) BATIK DYEING REVIEWED OF FASTNESS AND COLOR SHARPNESS

Dinamika Kerajinan dan Batik: Majalah Ilmiah, June 2024, Vol. 41. No. 1, pages 51 - 60

Batik cloth is colored with natural dyes and synthetic dyes. Synthetic dyes have the following advantages: various colors, guaranteed color brightness, stability, not easy to fade, resistance to various environmental conditions, good color strength, easy to obtain, and a economical price. However, the use of synthetic dyes in everyday life has a negative impact on the environment because they are carcinogenic. Thus, efforts are needed to produce natural dyes instead of synthetic ones. Jambal bark has potential as a natural dye because it contains (+)-leucocyanidin-3-O- $\alpha$ -D-galactopyranoside. This study used jambal bark with the influence of the type of concentration and fixation process time with concentrations of 20, 50, 70, and 90 g/L from the results of research conducted to determine the feasibility of the natural material Jambal Bark (*Peltophorum Pterocarpum*) Fabric, and the resulting L\*a\*b\* value is used for washing tests using soap (smoothness) to get a value of 4-5.

**Keywords:** Natural coloring, jambal bark, color fastness, fixation

DDC: 746.662

Arif Suharson

Deprtement of Craft, Faculty of Visual Art, Art Institute of Indonesia in Yogyakarta

email: [arifsuharson318@gmail.com](mailto:arifsuharson318@gmail.com)

#### SUSTAINABLE CREATIVE ARTWORK WITH THE UPCYCLING CONCEPT METHOD

Dinamika Kerajinan dan Batik: Majalah Ilmiah, June 2024, Vol. 41. No. 1, pages 61 - 74

Technological advances in human life have an impact on the increasing need for products or machine components applied to renewable work. The demands of human needs to meet the latest designs, appropriate technology or design trends, or other reasons leave products or components that were once considered new to become obsolete and even turn into garbage or waste. The purpose of the research is to understand the upcycling concept as a method for creative people in the world of fine arts to realize new works from old products, components, or goods to have novelty value or present the existence of products that have become waste or waste into sustainable works of art that are beneficial to human life in the midst of rapid changes in the world of industrial technology. The method used is descriptive analytical to examine sustainable artwork made from unused materials into valuable creative products. From this study, it was concluded that experiments conducted by artists supported by practice-based research methods to achieve artistic creations giving birth to sustainable creative arts could be realized. Products created from the upcycling concept method are in the form of creative works that can be used as aesthetic elements of interiors and exterior, artwork, or practical functional products that are used daily.

## DINAMIKA KERAJINAN DAN BATIK: MAJALAH ILMIAH

P-ISSN 2087-4294

E-ISSN 2528-6196

### ABSTRACT

Volume. 40, No.1, June 2024

**Keywords:** artist, artwork, sustainability, upcycling concept

DDC: 745.5

Idriwal Mayusda<sup>1</sup>, Radandio Radix Satriya<sup>1</sup>, Yenni Kristi Manik<sup>1</sup>, Annisa Dewi Akbari<sup>1</sup>, Amal Witonohadi<sup>1</sup>, and Muhammad Ihram Maulana<sup>2</sup>

<sup>1</sup>Department of Industrial Engineering, Universitas Trisakti, Jakarta, Indonesia

<sup>2</sup>Department of Mechanical Engineering, Universitas Trisakti, Jakarta, Indonesia

email: [idriwal.mayusda@trisakti.ac.id](mailto:idriwal.mayusda@trisakti.ac.id)

#### A PRELIMINARY DESIGN OF END EFFECTOR STAMP CANTING FOR BATIK STAMP AUTOMATED PRODUCTION USING DOBOT MAGICIAN ROBOTIC ARM

Dinamika Kerajinan dan Batik: Majalah Ilmiah, June 2024, Vol. 41. No. 1, pages 75 - 88

The lack of human resources (HR) hinders batik stamp production in Batik Kembang Mayang studio. At the same time, the high demand for batik must be fulfilled by the studio. This study aims to design an automated batik stamp production using the Robotic Arm "The Dobot Magician" as an alternative to achieve batik demand. The design was initiated by developing and testing a canting stamp tool on the Dobot Magician end effector. The development of canting stamp tool uses Quality Functions Deployment (QFD) method. The result showed 16 alternative designs of canting stamp tools based on the interpretation of Kembang Mayang Batik studio needs. Then, it is analyzed by Finite Element Analysis methods to get the proposed canting stamp tool design. The selected design of canting stamp tool has 13 attributes of tool specification. It uses polycarbonate material produced by additive manufacturing or 3D printing. Applying in Robotic Arm "Dobot Magician" showed it can produce a stamp batik.

**Keywords:** automation, batik, production, robotic arm, stamp canting

DDC: 677

Yuliarma dan Yunisa Ramadhani  
Padang State University, Padang, West Sumatera 25132, Indonesia  
Email: [yuliarmaincim@yahoo.com](mailto:yuliarmaincim@yahoo.com)

#### STUDY OF BATIK GAMBIR AS MINANGKABAU BATIK INNOVATIVE PRODUCT

Dinamika Kerajinan dan Batik: Majalah Ilmiah, June 2024, Vol. 41. No. 1, pages 95- 102

Dinamika Kerajinan dan Batik: Majalah Ilmiah. Vol. 41 No. 1, Juni 2024, hal. 95 - 108 Batik is the cultural heritage of the Indonesian community that has been worldwide. Each region has its own pattern. The objective of this research is to study gambir batik as an innovative product of Minangkabau batik,

covering the characteristics of motifs and coloring processes. The research method used is qualitative descriptive, with primary data sources: characteristics of motifs and coloring processes and secondary data: documentation and theoretical studies. The results of the research found 1) the shape of the motif of the gambir tigo sarumpun, tari payung, awan berarak, kelok rumah gadang 50 kota, and the rangkiang manjala as innovative batik motifs. The motif is inspired by the natural and cultural diversity of the district of Lima Puluh Kota, and 2) the coloring process uses natural coloring from gambir extract as an innovative batik coloring.

**Keywords:** gambier batik, innovative product, Minangkabau Batik

DDC: 658; 338

Tin Agustina Karnawati dan Fathorrahman  
Institut Teknologi dan Bisnis Asia Malang  
email: [agustina@asia.ac.id](mailto:agustina@asia.ac.id)

#### IDENTIFICATION OF BUSINESS DEVELOPMENT USING THE OVOP APPROACH IN EMBROIDERY HANDICRAFTS PRODUCT IN MALANG REGENCY

Dinamika Kerajinan dan Batik: Majalah Ilmiah, June 2024, Vol. 41. No. 1, pages 103 - 120

Improvement of community welfare can be done by developing regional potential through the utilization of local resource potential. One Village One Product (OVOP) approach is designed to increase the potential advantages of the village, thereby accelerating the rate of economic growth that is able to improve the welfare of the community. Embroidery craft products are one of the superior local products in the region that have the potential to develop. The purpose of this study is to identify problems to be able to formulate a business development model using the OVOP approach for embroidery craft products in Malang Regency. This type of research uses a qualitative descriptive approach and collecting data through observation and interviews. The results of the study indicate that the main problems are limited capital, knowledge of human resource factors, managerial skills and insights as well as marketing and business relations. The OVOP approach to the proposed prototype of a business development model requires initial observations on the 'need assessment' to provide further guidance in terms of managerial, technical and soft skills from the government, academics and practitioners or experts relevant to the needs of training materials.

**Keywords:** business development, embroidery handicrafts product, one village one product (OVOP)



## **A PRELIMINARY DESIGN OF END EFFECTOR STAMP *CANTING* FOR *BATIK* STAMP AUTOMATED PRODUCTION USING DOBOT MAGICIAN ROBOTIC ARM**

*Perancangan Awal End Effector Canting Cap untuk Produksi Batik Cap Terotomasi dengan Menggunakan Robotic Arm "Dobot Magician"*

**Idriwal Mayusda<sup>1</sup>, Radandio Radix Satriya<sup>1</sup>, Yenni Kristi Manik<sup>1</sup>, Annisa Dewi Akbari<sup>1</sup>, Amal Witonohadi<sup>1</sup>, Muhammad Ihram Maulana<sup>2</sup>**

<sup>1</sup> Department of Industrial Engineering, Universitas Trisakti, Jakarta, Indonesia

<sup>2</sup> Department of Mechanical Engineering, Universitas Trisakti, Jakarta, Indonesia

---

### **Corresponding Author**

Email : idriwal.mayusda@trisakti.ac.id

Naskah Masuk : 2 Agustus 2023

Revisi : 20 November 2023

Disetujui : 27 November 2023

---

*Keywords: automation, batik, production, robotic arm, stamp canting*

Kata kunci: otomasi, batik, canting cap, produksi, robotic arm

---

### **ABSTRACT**

The lack of human resources (HR) hinders batik stamp production in Batik Kembang Mayang studio. At the same time, the high demand for batik must be fulfilled by the studio. This study aims to design an automated batik stamp production using the Robotic Arm "The Dobot Magician" as an alternative to achieve batik demand. The design was initiated by developing and testing a canting stamp tool on the Dobot Magician end effector. The development of canting stamp tool uses Quality Functions Deployment (QFD) method. The result showed 16 alternative designs of canting stamp tools based on the interpretation of Kembang Mayang Batik studio needs. Then, it is analyzed by Finite Element Analysis methods to get the proposed canting stamp tool design. The selected design of canting stamp tool has 13 attributes of tool specification. It uses polycarbonate material produced by additive manufacturing or 3D printing. Applying in Robotic Arm "Dobot Magician" showed it can produce a stamp batik.

### **ABSTRAK**

Keterbatasan sumber daya manusia (SDM) menghambat produksi batik cap di sanggar Batik Kembang Mayang padahal permintaan batik yang tinggi harus dipenuhi oleh sanggar. Penelitian ini bertujuan untuk merancang produksi cap batik terotomasi menggunakan Robotic Arm "The Dobot Magician" sebagai alternatif untuk memenuhi permintaan tersebut. Perancangan dilakukan dengan menggunakan metode Quality Functions Deployment (QFD). Hasil penelitian memberikan 16 alternatif desain alat canting cap berdasarkan interpretasi kebutuhan sanggar Batik Kembang Mayang. Alternatif ini kemudian dianalisis dengan metode Finite Element Analysis untuk mendapatkan desain alat canting cap terpilih yang memiliki 13 atribut spesifikasi canting cap. Alat ini menggunakan material polikarbonat yang diproduksi dengan proses additive manufacturing atau 3D printing. Penerapan alat ini pada Robotic Arm "Dobot Magician" terbukti bisa menghasilkan batik cap.

## INTRODUCTION

Batik is a process that performs repeated coloring to create a design piece of fabric with traditional tools (Syed Shaharuddin et al., 2021). Batik has three types: *batik tulis* (written batik), *batik cap* (stamp batik), and batik of combination, which is a combination of batik stamp and written batik. In the production process, written batik takes more time than stamped batik. For one lot (110 pieces), written batik takes 6,594 minutes, while stamped batik takes approximately 912 minutes from cutting the cloth to the "*penglorodan*" process (Pratiwa Siregar et al., 2020).

The problem that often occurs today in making batik is the need for more skilled workers. The decrease in expert labor for batik is due to the current generation's lack of interest in batik, so human resources (HR) are significantly reduced in the production of traditional batik. Besides the threads in batik production, there is a hazard risk for the workers. It can harm the surrounding environment, namely health problems caused by heat exposure to wax vapors used in the batik-making process, such as clinical lungs and bronchitis (Dwinugroho et al., 2019).

The design and use of Computer Numerical Control (CNC) is an automation innovation widely developed in batik production, especially stamped batik. Among the research and development carried out by Dwinugroho (2019), Muthi'ah (2018), and Akhmad (2020). Apart from automated production, there is also the development of batik stamp canting materials, such as using a copper

electroforming process on acrylic material for batik stamp canting (Setiawan et al., 2020) and bamboo as an alternative to copper replacement material (Lias et al., 2020). Some technological developments still have gaps in automated batik production technology that can increase production capacity while maintaining the batik's originality by the batik's requirements. Based on these conditions, an automated batik production design was developed by applying the Dobot Magician robotic arm technology.

The Dobot Magician (Shenzhen Yuejiang Technology Co. Ltd, 2022) is a desktop four-axis manipulator with an accuracy of 0.2 mm based on an industrial chip. It is installed with different end-effectors and can accomplish functions such as drawing, writing, 3D printing, and laser engraving. The Dobot Magician has been commonly applied in academic research. For instance, Zhang et al. (2019) developed an intelligent system that redecorates Chinese handwriting characters and physically writes in a specified calligraphy style using The Dobot Magician. It used a brush operated by a robotic arm in the end effector section of The Dobot Magician. This research develops the automated batik process by designing and developing Batik Stamp tools in the end effector section of Dobot Magician robotic arm.

## Related Works

There is prior research in batik automation that closely relates to this study, as shown in Table 1.

**Table 1.** Previous Research in Batik Automation

Authors	Object	Output
(Muthi'ah, 2018)	Batik Written	Computerized-Batik using "Batik Kelowong" machine
(Dwinugroho et al., 2019)	Batik Stamped	Automatic Stamp Batik Machine Program with Automation Gripper
(Akhmad et al., 2020)	mBatik, CNC batik technology	Development of a wax applicator for mBatik, a written batik machine
(Setiawan et al., 2020)	Canting Stamped	Acrylic Canting Stamped with Copper Electroforming
(Lias et al., 2020)	Canting Stamped	Bamboo Batik Block

**Table 2.** Previous Research in Dobot Magician

Authors	Object	Output
(Ai et al., 2018)	Control System	Innovative control system architecture, adept at precisely monitoring the real-time trajectory of a robotic manipulator while maintaining a high level of stability.
(Zhang et al., 2019)	End Effector	Smart Chinese calligraphy of handwritten Dobot Magician robotic arm character
(Yamanaka et al., 2020)	End Effector	A novel robotic hand designed for food handling, capable of efficiently manipulating organic ingredients and swiftly transporting them.
(Tsai et al., 2021)	Drawing System	A pioneering development framework that seamlessly combines image processing and the creation of robot-arm drawings.

## RESEARCH METHODS

The process of developing tools in this study is to compile, design, and commercialize tools based on Quality Function Deployment (QFD) methods. The stages of concept selection have two stages to overcome difficulties in evaluating the concept of the product. Concept screening and assessment are the two stages (Ulrich et al., 2020; Wahyuni et al., 2020). The following

are the stages in product development carried out in this study.

a. Identifying Customer Needs.

This study found out and identified the customer needs based on a case study in Kembang Mayang Batik studio. It uses a focus group discussion (FGD) with the batik operator. The discussion results were interpreting user needs into customer needs.

b. Product Specifications.

Based on the previous result, specifications, and metrics will be determined to determine the needs of the tools to be designed. Then, it creates a need Metric-matrix, which is carried out to identify the relationship between pre-existing metric needs. The result obtained is a list of target specifications containing metrics, marginals, and values for these metrics.

c. Concept Generation.

Based on the metric specification, this stage explores the concept space to meet customer needs. The design concept had several alternative parts according to the needs and it is mapped through a concept classification tree.

d. Concept Selection and Concept Testing.

At this stage, various concepts are analyzed and disseminated to identify the most promising concepts, carried out several iterations with the creation of additional concepts and refinement. This study used the Finite Element Analysis (FEA) method to evaluate various concepts.

e. Prototyping.

This stage is used to create a design or model to be tested with the same properties in form and function before the final product. This study used 3D CAD Modelling and a product prototype based on the final selected concept in the previous stage.

## Objects

Batik Kembang Mayang studio is one of the batik producers that will be the object of this research. Several problems occur in Batik Kembang Mayang studio, namely the reduction of human resources (HR) who are experts or understand the process of making batik. In addition to problems regarding employment at the Kembang Mayang Batik Studio, most of the workers in this batik studio are elderly. Even though Batik Kembang Mayang studio lacks human resources (HR), the batik-making process still runs with sufficient capacity. Therefore, one of the alternative measures that will be carried out is to produce automated batik.

## RESULTS AND DISCUSSIONS

### *Identifying Customer Needs*

This initial stage uses a Focus Group Discussion (FGD) with the batik operator at Batik Kembang Mayang studio. FGD is divided into four questions: current conditions, things to like, things that are not liked, and proposed improvements in Batik Stamp's production. The discussion results were interpreting user needs into customer needs, and then changing customer needs into a hierarchy by dividing two groups, namely primary and secondary needs, as shown in Table 2. Primary Need is divided into three parts general needs; then secondary needs are obtained from customer needs that have been identified.



**Table 3.** Primary and Secondary Needs Interpretation

<b>Customer Needs Interpretation</b>	
<b>Primary Needs</b>	<b>Secondary Needs</b>
Supporting Tools in Batik Stamped Production	Tools are designed to make it easier the stamped batik process.
	Tools are designed to replace human repetition work.
	Tools are designed to use additional existing batik cap equipment.
Automated System	Tools are designed to carry out the production process automatically with the supervision of 1 operator.
	Tools are designed to have effective and efficient movement.
Ergonomics System	Tools are designed to be safe and comfortable to use.
	Tools are designed to carry out the production process without lifting or moving the batik stamp.
	Tools are designed to carry out the production process without workers having to stand constantly.

**Product Specification**

The limitations of tool design are based on the dimensions and specifications of Dobot Magician’s end effector, as shown below:

- The maximum weight of the tool is 500 grams.
- The tool is designed and integrated with a batik stamp.
- The tool created only has 1 type of motif that cannot be replaced other than changing the tool.
- Motifs of batik stamps are not complicated.
- The size of the batik stamp is limited to a maximum size of 10 cm X 10 cm.

During the initial product specification phase, the primary task involves defining specifications encompassing metrics and units relevant to the requirements of the tool

under development(Ulrich et al., 2020). Then identify the need metric matrix to determine the relationship between the primary need, secondary need, and the level of importance and its metrics. The importance level is determined from the result of FGD in the Customer Need Identification stage. This metric then determined the target value for each specification to define and target the proposed tools that suit the needs as shown in Table 4.

Furthermore, mapping the House of Quality (HOQ) to determine the highest value of our importance rating. Figure 1 is the result of HOQ mapping, based on the highest HOQ rating of 136 obtained from the sum of the overall multiplication results of each metric relationship with customer need.

**Table 4.** Metric List and Specification Units

Need Metric	Importance Level	Unit
Length of Main Body	4	cm
Width of the Main Body	4	cm
Height of the Main Body	4	cm
Design of the Main Body	5	subj
Length of Connecting Part	4	cm
Width of Connecting Part	4	cm
Height of Connecting Part	4	cm
Design of Connecting Part	5	subj
Length of Batik Stamp	4	cm
Width of Batik Stamp	4	cm
Height of Batik Stamp	4	cm
Design of Batik Stamp	5	subj
Total of Weight	5	gram
Materials	5	list

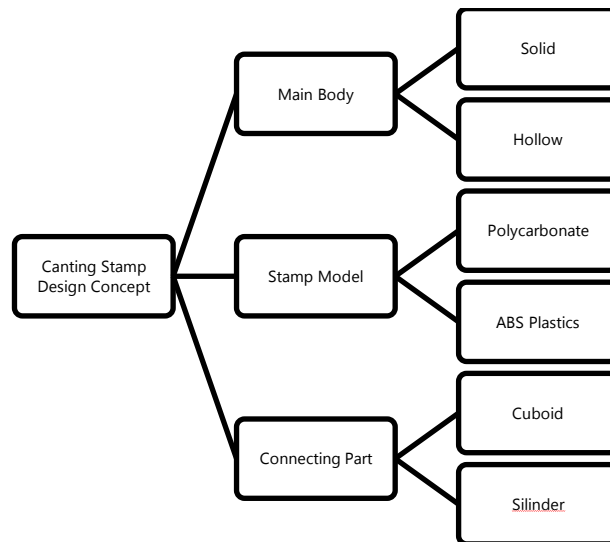

**Figure 1.** Concept Classification Tree

**Concept Generation**

The concept generation stage will be carried out to design the concept based on metric specifications, such as the tools, dimensions, and the materials used. Next, create a concept classification tree and map the concepts that will be used to select the best concept. The concept design consists of

three parts: main body, connecting parts, and stamp tool. Each of the parts has two alternative designs that are shown in Figure 1 as the concept classification tree.

Based on each alternative, there are 16 combinations of concepts in Canting Tool Design as shown in Table 5.

**Table 5.** Combinations of Concepts

Concept	Main Body	Connecting Part	Stamp Model	Materials
I	Solid	Cuboid	Single Parts	PC
	Hollow	Cylinder	Two Parts	ABS Plastics
II	Solid	Cuboid	Single Parts	PC
	Hollow	Cylinder	Two Parts	ABS Plastics
III	Solid	Cuboid	Single Parts	PC
	Hollow	Cylinder	Two Parts	ABS Plastics
IV	Solid	Cuboid	Single Parts	PC
	Hollow	Cylinder	Two Parts	ABS Plastics
V	Solid	Cuboid	Single Parts	PC
	Hollow	Cylinder	Two Parts	ABS Plastics
VI	Solid	Cuboid	Single Parts	PC
	Hollow	Cylinder	Two Parts	ABS Plastics
VII	Solid	Cuboid	Single Parts	PC
	Hollow	Cylinder	Two Parts	ABS Plastics
VIII	Solid	Cuboid	Single Parts	PC
	Hollow	Cylinder	Two Parts	ABS Plastics
IX	Solid	Cuboid	Single Parts	PC
	Hollow	Cylinder	Two Parts	ABS Plastics
X	Solid	Cuboid	Single Parts	PC
	Hollow	Cylinder	Two Parts	ABS Plastics
XI	Solid	Cuboid	Single Parts	PC
	Hollow	Cylinder	Two Parts	ABS Plastics
XII	Solid	Cuboid	Single Parts	PC
	Hollow	Cylinder	Two Parts	ABS Plastics
XIII	Solid	Cuboid	Single Parts	PC
	Hollow	Cylinder	Two Parts	ABS Plastics
XIV	Solid	Cuboid	Single Parts	PC
	Hollow	Cylinder	Two Parts	ABS Plastics
XV	Solid	Cuboid	Single Parts	PC
	Hollow	Cylinder	Two Parts	ABS Plastics
XVI	Solid	Cuboid	Single Parts	PC
	Hollow	Cylinder	Two Parts	ABS Plastics

**Concept Selection and Testing the Concept**

The concept selection and concept testing stages are assessed using the Finite Element Analysis (FEA) method which is simulated in ANSYS software (Ali et al., 2021).

Additionally, the aim is to analyze the mechanical strength of concept design to choose the best alternative concept. The result of the FEA simulation is shown in Figure 2.

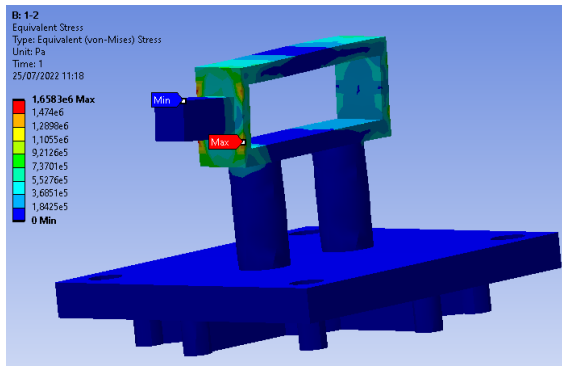

Concept I

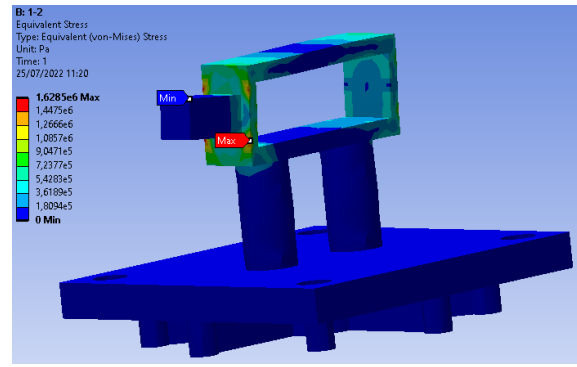

Concept II

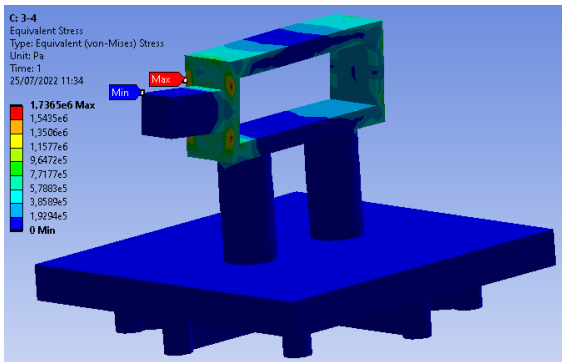

Concept III

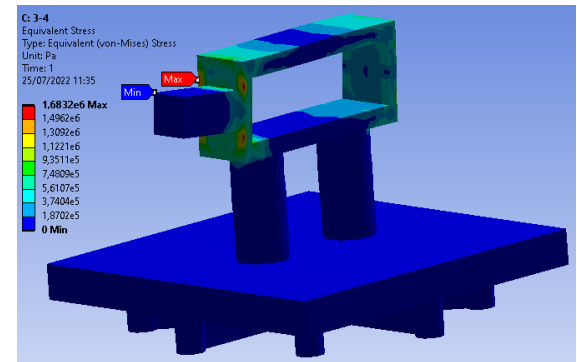

Concept IV

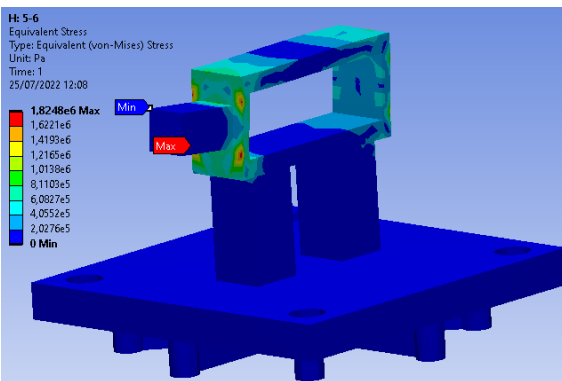

Concept V

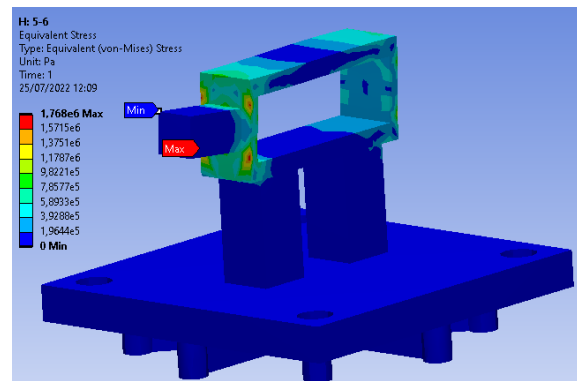

Concept VI

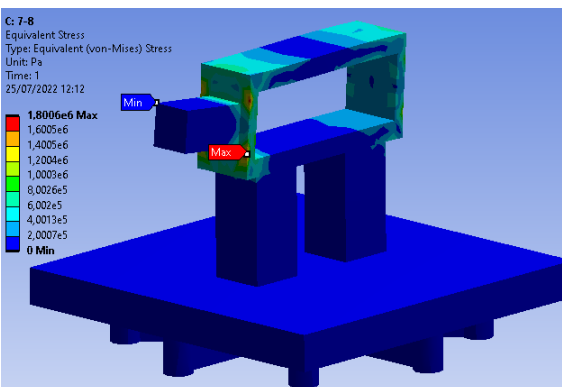

Concept VII

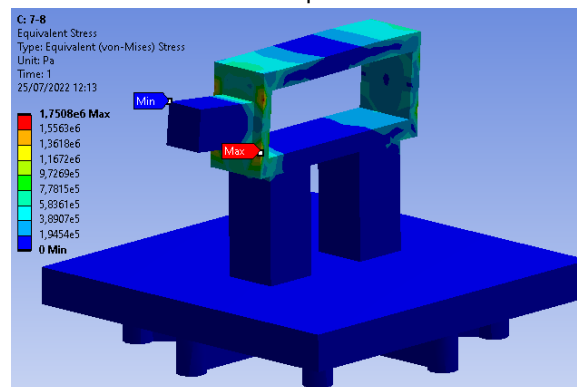

Concept VIII

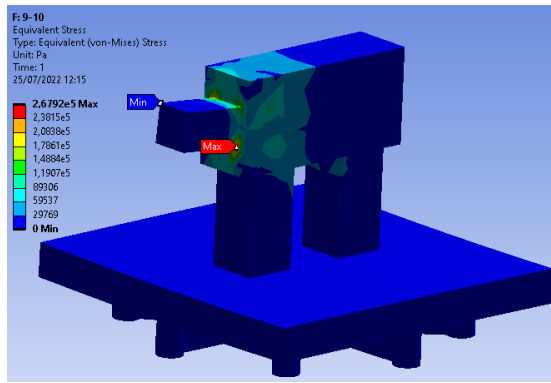

Concept IX

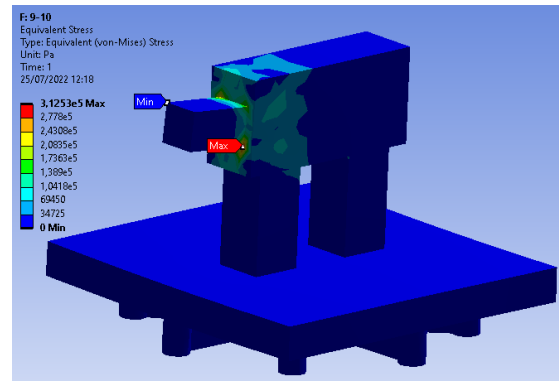

Concept X

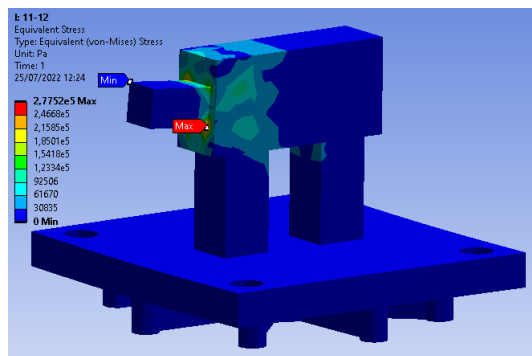

Concept XI

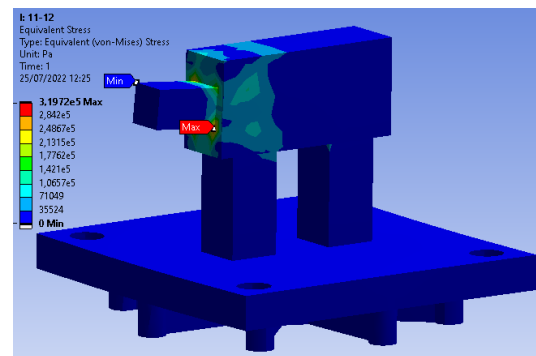

Concept XII

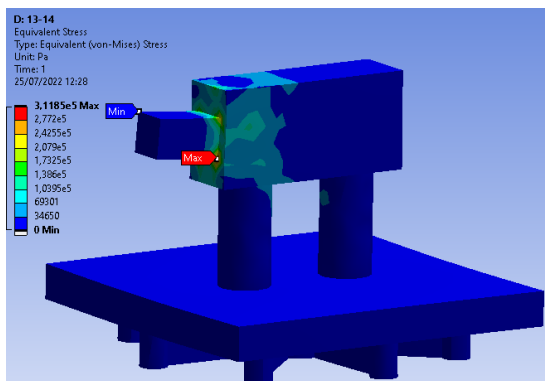

Concept XIII

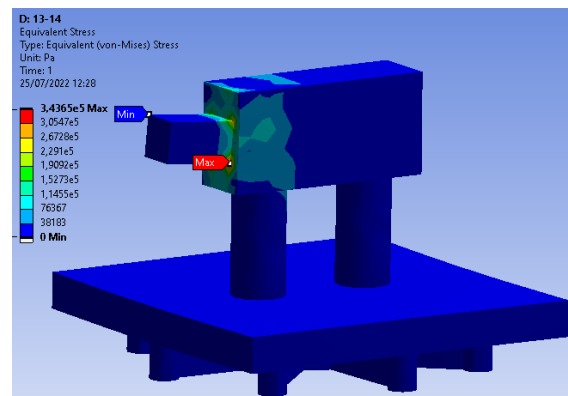

Concept XIV

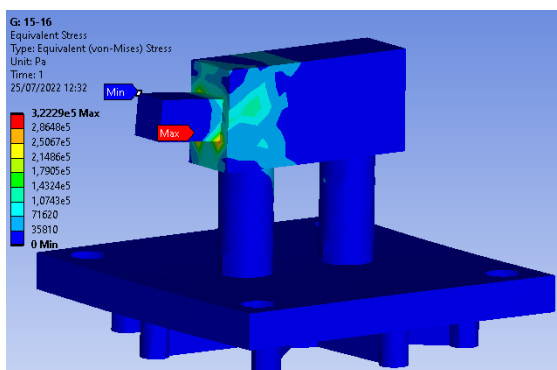

Concept XV

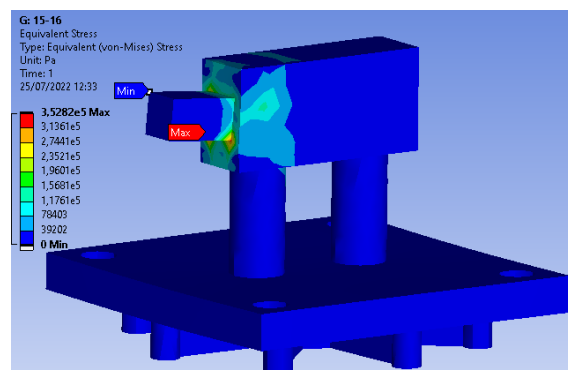

Concept XVI

Figure 2. FEA Simulation Results in ANSYS Software

Based on the simulation result shown in Figure 2, it can be noticed that the whole stress is concentrated on the end effector connector to Dobot Magician robotic arm. The region with the highest concentration of the von-Mises stress (joints) reflects the risk of fracture. This result becomes a consideration in concept selection and testing through the matrix screening and scoring concepts to rate the chosen alternative design. The weighting of the criterion comes from the sum of the importance levels of each criterion in the previous stage. Then the average value is converted into a weighted percent

obtained from the average divided by the total number of averages multiplied by 100%. Table 6 is a matrix scoring concept table that shows the best ranking table selected is Concept XI with a total score rank of 5.00. It means that Concept XI which has specifications with **a solid main body, cylinder connecting parts, two parts separated stamp model, and polycarbonate material** will be produced using 3D printing method.

**Table 6.** Matrix Scoring Concept

Matrix Scoring Concept									
Criteria Selection	Weight	Concept II		Concept IV		Concept XI		Concept XII	
		Rtg	Ws	Rtg	Ws	Rtg	Ws	Rtg	Ws
Dobot & Tools facility	28.58	4	1.14	3	0.86	5	1.43	3	0.86
Automated System	35.05	3	1.05	4	1.40	5	1.75	3	1.05
Ergonomics System	36.37	5	1.82	5	1.82	5	1.82	5	1.82
TOTAL	100%	4.01		4.08		5.00		3.73	
Rank		3		2		1		4	
Continue		Yes		No		Yes		No	

Notes:  
Rtg : Rating  
Ws : Weighted Score

**Prototyping**

The last stage in this study is prototyping. This study will be used to design services and software that must be designed and manufactured in 3D CAD

Modelling. Based on the selected concept of end effector stamp canting, Table 7 shows the detailed specification of Concept XI.

**Table 7.** Detail Specification of The Selected Concept

Parts	Dimension	
Main Body	Shape	Cuboid
	Length	5.7 cm
	Width	1.8 cm
	Height	2.7 cm
Connecting Parts	Diameter	1.8 cm
	Height	3 cm
	Shape	Cylinder
Batik Stamp	Length	10 cm
	Width	10 cm
	Height	2 cm
	Model	2 Separated Parts
Total Weight	≤ 500 kg	
Materials	<i>Polycarbonate</i>	

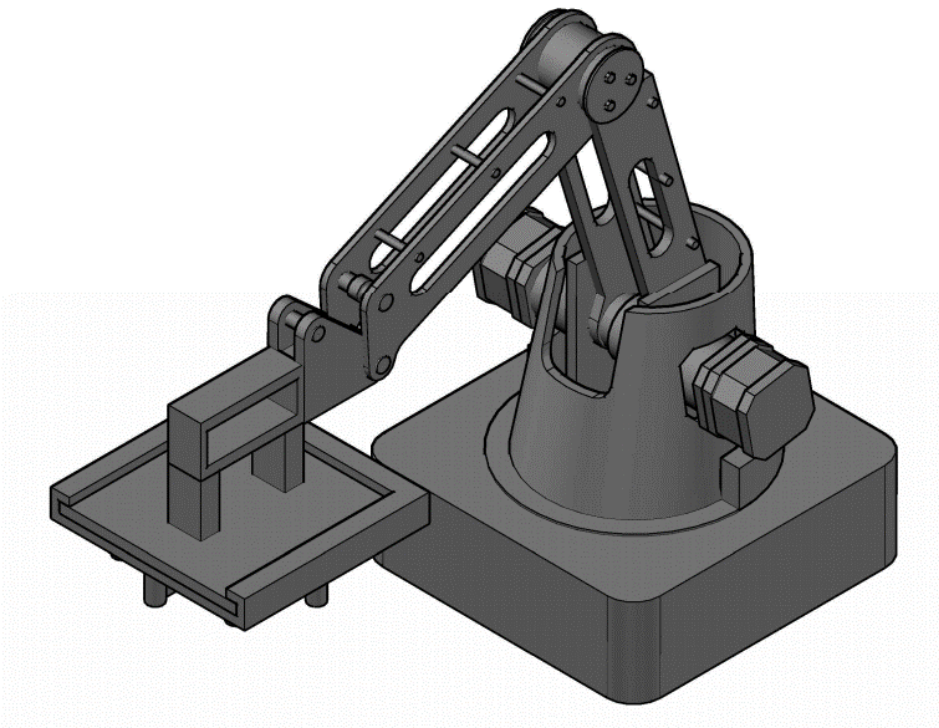

**Figure 3.** 3D CAD Model of End Effector Stamp *Canting* in Dobot Magician

Figure 3 shows 3D CAD Modelling of end effector stamp canting in Dobot Magician Robotic Arm. Figure 4 shows a viewport and Figure 5 is a 3D plotter of product details of the end effector tool stamp canting selected

concept. Figure 6 shows the result of 3D Printing end effector tool stamp canting prototyping where it is used in the Batik Stamp Process as shown in Figure 7.

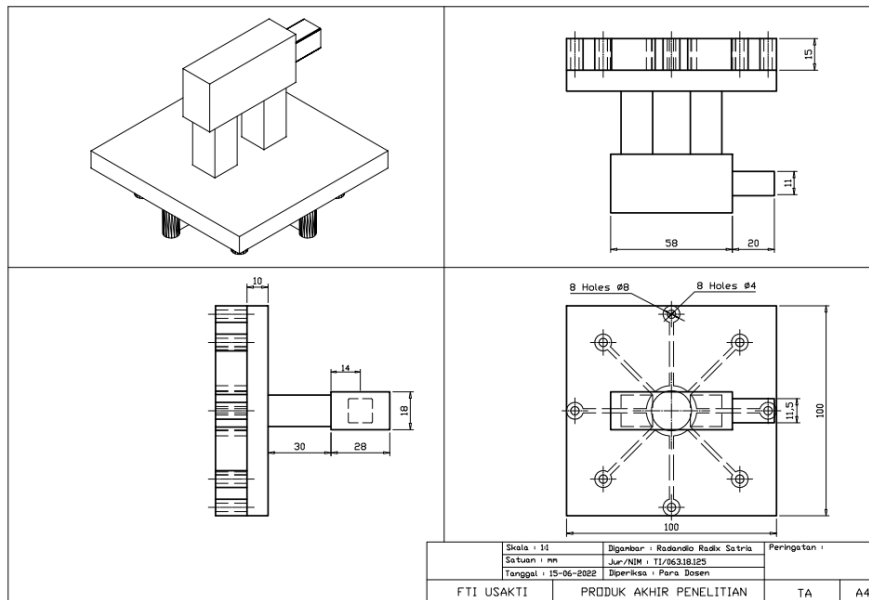

Figure 4. Viewport Product Detail Tool Canting Cap Concept XI

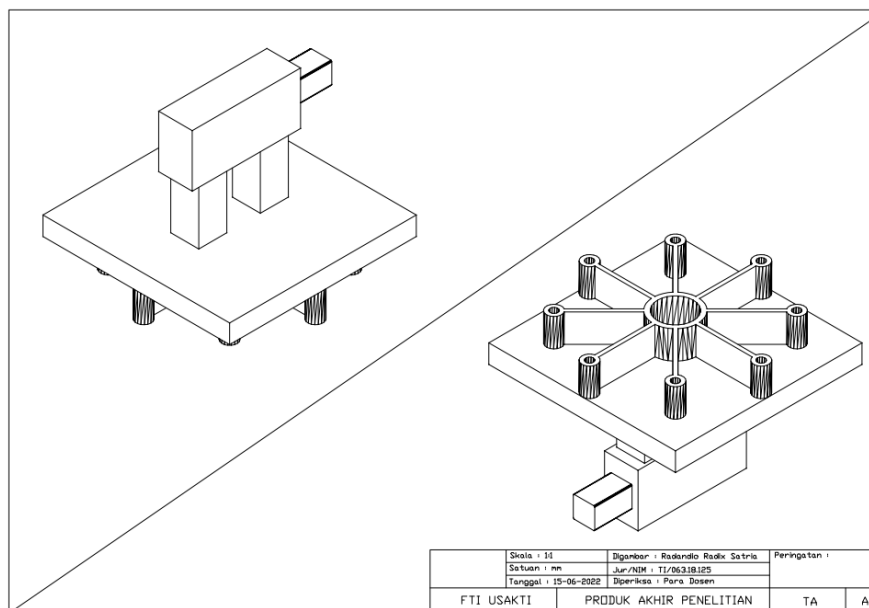

Figure 5. Plotter Product Detail Tool Canting Cap Concept XI

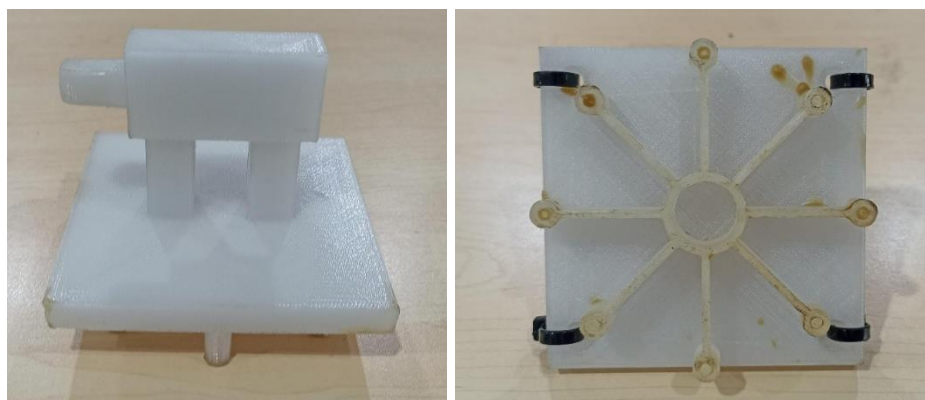

Figure 6. Prototyping of Selected Concept XI





**Figure 7.** Prototyping of Selected Concept XI in Batik Stamp Process

## CONCLUSION

This study develops a preliminary design concept of an end effector batik stamp *canting* tool with **a solid main body, cylinder connecting parts, two parts separated stamp model, and polycarbonate material** that will be produced using 3D Printing. The Quality Function Deployment methods have only been tested in the prototype stage, but the results are promising and can be used to further research in batik automated production.

## AUTHOR'S CONTRIBUTION

Conceptualization, I.M., R.S.S., and Y.K.M.; methodology, I.M., R.S.S., and A.W.; validation, I.M., and M.I.M.; formal analysis, I.M., A.W., and A.D.A.; investigation, I.M., R.S.S., and Y.K.M.; writing—original draft preparation, I.M., R.S.S., and Y.K.M.; writing—review and editing, I.M., Y.K.M. and A.W.; supervision, I.M., and A.W. All authors have read and agreed to the published version of the manuscript.

## ACKNOWLEDGMENT

This research was supported by the Industrial Technology of Faculty Universitas Trisakti Research Grant.

## REFERENCES

- Ai, Q., Yang, Q., Li, M., Feng, X., & Meng, W. (2018). Implementing Multi-DOF Trajectory Tracking Control System for Robotic Arm Experimental Platform. *Proceedings - 10th International Conference on Measuring Technology and Mechatronics Automation, ICMTMA 2018, 2018-January*, 282–285. <https://doi.org/10.1109/ICMTMA.2018.00075>
- Akhmad, S., Arendra, A., Mu'Alim, Winarso, K., & Hidayat, R. (2020). Design of the Batik, textile hot wax applicator to emulate hand drawn batik using CNC plotter machine and characterization of wax plotting parameters. *Journal of Physics: Conference Series*, 1569(3). <https://doi.org/10.1088/1742-6596/1569/3/032026>
- Ali, H. Md., Smagulov, Z., & Otepbergenov, T. (2021). Finite Element Analysis of The CFRP-based 3D Printed Ankle-Foot

- Orthosis. *Procedia Computer Science*, 196, 217–225.  
<https://doi.org/10.1016/j.procs.2021.12.008>
- Dwinugroho, T. B., Kumarajati, D. Y. H., Kurniawanti, & Hapsari, Y. T. (2019). Design and Implementation of CNC (Computer Numerical Control) Based Automatic Stamp Batik Machine Program with Automatic Gripper Using Mach 3. *Journal of Physics: Conference Series*, 1254(1). <https://doi.org/10.1088/1742-6596/1254/1/012069>
- Lias, H., Ismail, A. R., Jusoh, N., & Hamid, H. A. (2020). Technological development of bamboo for “Batik” stamp in Malaysian textile industries. *IOP Conference Series: Earth and Environmental Science*, 616(1). <https://doi.org/10.1088/1755-1315/616/1/012037>
- Muthi’ah, W. (2018). Study of Computerized-Batik Technique Using “Batik Kelowong” Machine in Batik Adelia, Bekasi. *IOP Conference Series: Materials Science and Engineering*, 453(1). <https://doi.org/10.1088/1757-899X/453/1/012022>
- Pratiwa Siregar, A., Bihrajihant Raya, A., Dwi Nugroho, A., Indana, F., Made Yoga Prasada, I., Andiani, R., Gracia Yunindi Simbolon, T., & Tri Kinasih, A. (2020). Batik Industry Development Efforts In Indonesia. *Dinamika Kerajinan Dan Batik*, 37(1), 79–92.  
<https://doi.org/10.22322/dkb.V36i1.4149>
- Setiawan, J., Istihanah Nurul Eskani Balai Besar Kerajinan dan Batik Yogyakarta, dan, & Kusumanegara No, J. (2020). *Prosiding Seminar Nasional Teknik Kimia “Kejuangan” Proses Electroforming Tembaga pada Bahan Acrylic untuk Prototype Canting Cap Batik*. Jurusan Teknik Kimia, 14–15.
- Shenzhen Yuejiang Technology Co. Ltd. (2022).
- Dobot Magician Specifications/Shipping List/API Description*. Available Online: <https://www.dobot.cc/>.
- Syed Shaharuddin, S. I., Shamsuddin, M. S., Drahman, M. H., Hasan, Z., Mohd Asri, N. A., Nordin, A. A., & Shaffiar, N. M. (2021). A Review on the Malaysian and Indonesian Batik Production, Challenges, and Innovations in the 21st Century. *SAGE Open*, 11(3).  
<https://doi.org/10.1177/21582440211040128>
- Tsai, P. S., Wu, T. F., Chen, J. Y., & Lee, F. H. (2021). Drawing system with dobot magician manipulator based on image processing. *Machines*, 9(12).  
<https://doi.org/10.3390/machines9120302>
- Ulrich, K., Eppinger, S., & Yang, M. C. (2020). *Product Design and Development*. McGraw-Hill Education.
- Wahyuni, R. S., Nursubiyantoro, E., & Awaliah, G. (2020). Perancangan dan Pengembangan Produk Helm Menggunakan Metode Quality Function Deployment (QFD). *OPSI*, 13(1), 6.  
<https://doi.org/10.31315/opsi.v13i1.3466>
- Yamanaka, Y., Katagiri, S., Nabae, H., Suzumori, K., & Endo, G. (2020). Development of a Food Handling Soft Robot Hand Considering a High-speed Pick-and-place Task. *Proceedings of the 2020 IEEE/SICE International Symposium on System Integration*, 87–92.
- Zhang, X., Li, Y., Zhang, Z., Konno, K., & Hu, S. (2019). Intelligent Chinese calligraphy beautification from handwritten characters for robotic writing. *Visual Computer*, 35(6–8), 1193–1205.  
<https://doi.org/10.1007/s00371-019-01675-w>