



*journal*  
**INDUSTRIAL  
SERVICES**

Vol. XXX No. XXX YEAR XXXX



Table of Content

Vol 11, No 2 (2025): October 2025

Table of Contents

Articles

<a href="#"><u>Study of the effect of conversations in memorization activities on short-term memory, drowsiness level, and heart rate of college students</u></a> <i>Grace Vania, Elty Sarvia, Novi Soesilo</i>	<a href="#">PDF</a> 167-176
<a href="#"><u>Electricity demand forecasting model in ASEAN integrated with copulas based on deep learning</u></a> <i>I Nyoman Bima Permana, Anak Agung Istri Agung Sri Komaladewi, I Gusti Ngurah Priambadi</i>	<a href="#">PDF</a> 177-190
<a href="#"><u>Designing a user-centric application for electric vehicle battery replacement station search using design thinking and HCD principles</u></a> <i>Silvi Istiqomah, Perdana Suteja Putra</i>	<a href="#">PDF</a> 191-198
<a href="#"><u>Service blueprint design for digital waste bank: An online-to-offline (O2O) service marketing approach</u></a> <i>Sari Wulandari, Intan Permatasari, Meldi Rendra</i>	<a href="#">PDF</a> 199-214
<a href="#"><u>Multi-factor sales and stock forecasting for drinking water with machine learning: A case study of an MSME</u></a> <i>Baban Subandi, Dyah Lestari Widaningrum</i>	<a href="#">PDF</a> 215-227
<a href="#"><u>Embeddedness in marketing ecosystems: Linking relationships and structures for competitive advantage in MSMEs</u></a> <i>Fira Kuni Afifa, Diana Dewi Sartika, Adetia Wulindari, Rudy Kurniawan, Deska Fitriyani, Muhammad Yusuf Abror</i>	<a href="#">PDF</a> 228-238
<a href="#"><u>Identifying key criteria and driving variables for enhancing higher education accreditation rankings: A systematic literature review</u></a> <i>Mukhamad Abduh, Triwulandari Satitidjati Dewayana, Docki Saraswati, Indra Surjati</i>	<a href="#">PDF</a> 239-248
<a href="#"><u>Optimizing outpatient healthcare quality through gap analysis and TRIZ-based problem solving</u></a> <i>Riski Arifin, Sri Rahmawati, Ahmad Akral Bukhra</i>	<a href="#">PDF</a> 249-258
<a href="#"><u>A hybrid fuzzy for supplier selection optimization of steel raw materials</u></a> <i>Erni Krisnaningsih, Muhammad Rifki Nuryusuf, Saleh Dwiyatno, Dadi Cahyadi, Arief Suwandi</i>	<a href="#">PDF</a> 259-268

<p><a href="#"><u>UTAUT model in the context of public service: The role of organizations in the digitalization of cooperative websites</u></a></p> <p><i>Rizqi Atikah Salsabila, M Fathur Rahman</i></p>	<p><a href="#">PDF</a></p> <p>269-277</p>
<p><a href="#"><u>Integrating ergonomic intervention and digital human modelling for posture improvement in welding tasks</u></a></p> <p><i>Sanfransyul Arung Tasik, Rahmi Maulidya, Ika Wahyu Utami, Dian Mardi Safitri, Novia Rahmawati, Anik Nur Habyba</i></p>	<p><a href="#">PDF</a></p> <p>278-299</p>
<p><a href="#"><u>Economic order quantity (EOQ) approach for wood inventory optimization and cost reduction: A case study of a corn-drying company</u></a></p> <p><i>Stella Junus, Ruchbandi Rahmat T. Yasin</i></p>	<p><a href="#">PDF</a></p> <p>300-308</p>
<p><a href="#"><u>Cocoa bean post-harvest risk analysis with enterprise risk management (ERM) method approach</u></a></p> <p><i>Burhan Burhan, Ryan Nur Hidayat, Hamzah Fansuri</i></p>	<p><a href="#">PDF</a></p> <p>309-320</p>
<p><a href="#"><u>A Bayesian MEWMA control chart for monitoring water quality in public utilities</u></a></p> <p><i>Surya Puspita Sari, Aditya Putra Pratama, Riki Herliansyah, Ferdy Novri</i></p>	<p><a href="#">PDF</a></p> <p>321-340</p>
<p><a href="#"><u>Business continuity maturity in the banking industry: A governance perspective</u></a></p> <p><i>Indryadi Hardi, Dadan Umar Daihani, Rina Fitriana, Juniati Gunawan</i></p>	<p><a href="#">PDF</a></p> <p>341-349</p>
<p><a href="#"><u>Advantages of Using the Soft System Dynamics Methodology (SSDM) Approach in Research: A Literature Review</u></a></p> <p><i>Ciptono Setyo Budi, Triwulandari Satitidjati Dewayana, Emelia Sari, Indra Surjati</i></p>	<p><a href="#">PDF</a></p> <p>350-363</p>
<p><a href="#"><u>Supply chain resilience in beverage industry: A hybrid systematic literature review and bibliometric analysis</u></a></p> <p><i>Puji Rahayu, Pudji Astuti, Nora Azmi, Engelin Shintadewi Julian</i></p>	<p><a href="#">PDF</a></p> <p>364-378</p>
<p><a href="#"><u>Optimizing nurse shift scheduling using integer linear programming: A case study in inpatient wards</u></a></p> <p><i>Evi Febianti, I Dewa Ketut Sudarsana, Wahyu Susihono, Anak Agung Istri Agung Sri Komaladewi, Kulsum Kulsum, M. Adha Ilhami, Farhan Arzi Wardono</i></p>	<p><a href="#">PDF</a></p> <p>379-385</p>
<p><a href="#"><u>Bibliometric analysis on the term “human capital” and “university performance”</u></a></p> <p><i>Hadi Setiawan, I Dewa Ketut Sudarsana, Wahyu Susihono, Anak Agung Istri Agung Sri Komaladewi, Muhammad Adha Ilhami</i></p>	<p><a href="#">PDF</a></p> <p>386-394</p>

<p><a href="#"><u>A batch scheduling model for minimizing the sum of weighted tardiness and lateness in tableware manufacturing</u></a></p> <p><i>Andhika Kurniawan, Lely Herlina, Muhammad Adha Ilhami, Lovely Lady, Ade Sri Mariawati, Ratna Ekawati</i></p>	<p><a href="#">PDF</a></p> <p>395-402</p>
<p><a href="#"><u>Conversion of rice straw into CMC via controlled ultrasonic-assisted</u></a></p> <p><i>Nufus Kanani, Wardalia Wardalia, Heri Heriyanto, Rudi Hartono, Rusdi Rusdi, Muhammad Triyogo Adiwibowo, Dhini Maulana Dewi, Muhammad Zidane Ramadhana</i></p>	<p><a href="#">PDF</a></p> <p>403-411</p>
<p><a href="#"><u>Clustering musculoskeletal disorders risk in Banten's small food industries: A postural analysis for sustainable workforce health</u></a></p> <p><i>Nustin Merdiana Dewantari, Yusraini Muharni, Lovely Lady, Nurul Ummi, Ade Sri Mariawati, Lely Herlina</i></p>	<p><a href="#">PDF</a></p> <p>412-419</p>
<p><a href="#"><u>The influence of halal industry growth in achieving Sustainable Development Goals: A bibliometric approach</u></a></p> <p><i>Yusraini Muharni, Tajul Arifin, Yadi Janwari, Elis Ratna Wulan, Ian Rakhmawan Suherli, Maria Ulfah</i></p>	<p><a href="#">PDF</a></p> <p>420-427</p>
<p><a href="#"><u>Customer satisfaction assessment of female convenience store workers using the customer satisfaction index</u></a></p> <p><i>Chyntia Devi Octaviany, Nurul Ummi, Aditya Rahadian Fachrur</i></p>	<p><a href="#">PDF</a></p> <p>428-436</p>
<p><a href="#"><u>Enhancing mechanical properties of spent coffee ground-reinforced composites: The role of coupling agents in sustainable material development</u></a></p> <p><i>Wardalia Wardalia, Nufus Kanani, Rudi Hartono, Rusdi Rusdi, Heri Heriyanto</i></p>	<p><a href="#">PDF</a></p> <p>437-445</p>
<p><a href="#"><u>Catalytic Performance of Calcined Bayah Natural Zeolite and Mg–Ca–Ba Modified ZSM-5 in Methanol-to-Olefins Conversion</u></a></p> <p><i>Heri Heriyanto, Teguh Kurniawan, Endang Suhendi, Sri Djakung Sumbogo Murti, Hens Saputra</i></p>	<p><a href="#">PDF</a></p> <p>446-453</p>
<p><a href="#"><u>Modeling the determinants of outsourcing performance in the poultry supply chain using SEM-PLS</u></a></p> <p><i>Miranda Putri Simatupang, Ambiyar Ambiyar, M. Giatman, Remon Lapisa, Lasyatta Syaifullah, Iffarial Nanda</i></p>	<p><a href="#">PDF</a></p> <p>454-465</p>
<p><a href="#"><u>Development of a fuzzy logic-based sustainable ergonomic assessment method for identifying occupational health risks in the manufacturing sector</u></a></p> <p><i>Silvi Rushanti Widodo, Lolyka Dewi Indrasari</i></p>	<p><a href="#">PDF</a></p> <p>466-474</p>

<p><a href="#">Sustainable manufacturing supply chain resilience: A novel multi-criteria framework integrating fuzzy AHP and MAUT methodologies</a></p> <p><i>Siti Nurmalasari, Muhammad Asrol</i></p>	<p><a href="#">PDF</a></p> <p>475-484</p>
<p><a href="#">The effect of EMS and UV-C mutagenesis on microalgae biomass and lipid productivity under varying harvesting times</a></p> <p><i>Elida Purba, Navira Ebella</i></p>	<p><a href="#">PDF</a></p> <p>485-490</p>
<p><a href="#">Logistics vendor selection in waste transportation using an integrated AHP–TOPSIS approach</a></p> <p><i>Athariq Dias Muyasar, Taufik Roni Sahroni</i></p>	<p><a href="#">PDF</a></p> <p>491-497</p>
<p><a href="#">Budget allocation strategies for risk mitigation in halal slaughterhouses: a systematic literature review</a></p> <p><i>Melfa Yola, Rika Ampuh Hadiguna, Alexie Heryandie Bronto Adi, Mohamad Ikbar Abdul Wahab</i></p>	<p><a href="#">PDF</a></p> <p>498-507</p>
<p><a href="#">User satisfaction analysis of an Innovation on Supply Loss (IOS) system in the commercial and trading sector using the PIECES–usability framework and binary logistic regression</a></p> <p><i>Marsya Muthiah Lazuardy, Elfira Febriani Harahap, Anik Nur Habyba</i></p>	<p><a href="#">PDF</a></p> <p>508-517</p>
<p><a href="#">Interdependency model between project delay risks using fuzzy interpretive structural modeling at project and asset management construction company</a></p> <p><i>Ririn Regiana Dwi Satya, Nabila Azzahra Abdurrohman, Laela Chairani, Sodikun Sodikun</i></p>	<p><a href="#">PDF</a></p> <p>518-526</p>
<p><a href="#">Relationship between physical workload and work fatigue in labor-intensive manufacturing: An integrated CVL and SSRT approach</a></p> <p><i>Muchlis Aditya Faqih, Anastasia Febiyani, Aswan Munang</i></p>	<p><a href="#">PDF</a></p> <p>527-536</p>
<p><a href="#">Multivariate statistical process monitoring of reservoir water quality using MEWMA and MEWMV control charts</a></p> <p><i>Anggela Puspita, Surya Puspita Sari, Aditya Putra Pratama</i></p>	<p><a href="#">PDF</a></p> <p>537-546</p>
<p><a href="#">Lead time reduction in die manufacturing through a hybrid continuous improvement approach integrating eight-step, SMART, and quality control tools</a></p> <p><i>Edward Rosyidi, Nensi Yuselin, Ibrahim Anton Surya Atmaja</i></p>	<p><a href="#">PDF</a></p> <p>547-556</p>
<p><a href="#">Illegal levies in freight transport: A comparative analysis of Indonesian and German freight forwarding regulations toward international standards</a></p> <p><i>Muhammad Aditya, Enda Permana, Vina Dwiyanti</i></p>	<p><a href="#">PDF</a></p> <p>557-567</p>

<a href="#">Mapping performance of batik SMEs: A perspective on green innovation, green culture, and green employee behavior through clustering algorithm</a> <i>Fandi Achmad, Amelia Kurniawati, Fahmy Habib Hasanudin, Iwan Inrawan Wiratmadja</i>	<a href="#">PDF</a> <a href="#">PDF</a> 568-579
<a href="#">Supply chain viability as a driver of FMCG reconfiguration post-disruption: A regional comparison</a> <i>Sherlywati Sherlywati, Eliot Simangunsong, Fathony Rahman, Hesti Maheswari</i>	<a href="#">PDF</a> 580-593
<a href="#">Mitigation of supply chain risks of very small aperture terminal antenna in the satellite-based telecommunication industry</a> <i>Fatahillah Ahmad, Qurtubi Qurtubi</i>	<a href="#">PDF</a> 594-603
<a href="#">Dynamic modeling of inventory systems under supplier delay: A system dynamics approach</a> <i>Fredy Sumasto, Ridho Hans Gurning, Dewi Auditiya Marizka, Febriza Imansuri, Irma Agustiniingsih Imdam, Indra Rizki Pratama, Adam Satria</i>	

## Editorial Team

### Editor-in-Chief

1. [Bobby Kurniawan](#), Department of Industrial Engineering, Universitas Sultan Ageng Tirtayasa, Indonesia

### Associate Editors

1. [Dr. Lely Herlina](#), Department of Industrial Engineering, Universitas Sultan Ageng Tirtayasa, Indonesia
2. [Akbar Gunawan, ST., MT](#), Universitas Sultan Ageng Tirtayasa, Indonesia
3. [Anik Nur Habyba, S.TP., M.Si.](#), Universitas Trisakti, Indonesia
4. [Ir. Indra Setiawan, ST., MT](#), ASTRA Polytechnic, Indonesia
5. [Atia Sonda](#), Sultan Ageng Tirtayasa University

### Editor: Smart Manufacturing System and IOT

1. [Dr Imamul Muttakin](#), Universitas Sultan Ageng Tirtayasa, Indonesia

### Editor: Supply Chain Management

1. [Prof. Dr.-Ing. Asep Ridwan](#), Universitas Sultan Ageng Tirtayasa, Indonesia
2. [Prof. Dr. Wahyudi Sutopo](#), Universitas Negeri Sebelas Maret, Surakarta, Indonesia
3. [Ivonne Ayesha](#), Universitas Muhammadiyah Bandung, Indonesia
4. [Rizki Prakasa Hasibuan](#), Universitas Ibnu Sina, Batam, Indonesia

### Editor: Mathematical Modeling

1. [Prof. Hennie Husniah](#), Universitas Langlang Buana, Indonesia

**Editor: Ergonomic, Occupational Health and Safety Environment**

1. [Prof. Dr. Wahyu Susihono](#), Universitas Sultan Ageng Tirtayasa, Indonesia
2. [Dr. Lovely Lady, ST., MT](#), Universitas Sultan Ageng Tirtayasa, Indonesia
3. [Vivi Mardian](#), Universitas Pendidikan Indonesia, Indonesia

**Editor: Manufacturing Process**

1. [Dr. Mekro Permana Pinem, ST., MT.](#), Universitas Sultan Ageng Tirtayasa, Indonesia

**Editor: Industrial Management**

1. [M. Mujiya Ulkhaq](#), Diponegoro University, Indonesia
2. [Noveri Maulana](#), Sekolah Tinggi Manajemen PPM-Jakarta, Indonesia

**Editor: Production Control and Scheduling**

1. [B. Handoko Purwojatmiko](#), Politeknik STMI Jakarta, Indonesia
2. [Arrazy Elba Ridha, S.ST., M.T.](#), Universitas Teuku Umar, Indonesia

**Production Editor**

1. [Rema Sufiatika](#), Department of Industrial Engineering, Universitas Sultan Ageng Tirtayasa, Indonesia

## *Reviewer*

[Dr Adekunle Ibrahim Musa](#), Department of Mechanical Engineering Olabisi Onabanjo University Ago Iwoye Ogun State Nigeria, Nigeria

[Dr. B. Dhanasakkaravarthi](#), Agni College of Technology, India

[Dr. Wen Song](#), Waseda University, Japan

[Fellek Getu Tadesse](#), School of Mechanical and industrial Engineering, Ethiopian Institute of Technology-Mekelle, Ethiopia, Ethiopia

[Dr. Muhammad Hisjam](#), Universitas Negeri Sebelas Maret, Surakarta, Indonesia

[Dr. Dwi Kurniawan, ST., MT.](#), Institut Teknologi Nasional, Indonesia

[Dr. Rully Tri Cahyono](#), Department of Industrial Engineering Faculty of Industrial Technology Institut Teknologi Bandung, Indonesia

[Romadhani Ardi](#), Universitas Indonesia, Indonesia

[Afrin Fauzya Rizana](#), Telkom University, Indonesia

[Aisyah Larasati](#), Universitas Negeri Malang, Indonesia

[Yeni Roha Mahariani](#), Universitas Bhinneka PGRI, Indonesia

[Pangki Suseno](#), Universitas Bhinneka PGRI, Indonesia

[Artamevia Salsabila Rizaldi](#), Telkom University, Indonesia

[Bimastyaji Surya Ramadan](#), Universitas Diponegoro, Indonesia

[Indri Hapsari](#), University of Surabaya, Indonesia

[Muhammad Hasan](#), Universitas Negeri Makassar, Indonesia

[Dr. Ani Umyati](#), Department of Industrial Engineering, Universitas Sultan Ageng Tirtayasa

[Dr. Sirajuddin Sirajuddin](#), Department of Industrial Engineering, Universitas Sultan Ageng Tirtayasa, Indonesia

[Dr. Nurul Umami](#), Department of Industrial Engineering, Universitas Sultan Ageng Tirtayasa, Indonesia

[Dr. Ade Sri Mariawati](#), Department of Industrial Engineering, Universitas Sultan Ageng Tirtayasa, Indonesia

[Dr. Evi Febianti](#), Department of Industrial Engineering, Universitas Sultan Ageng Tirtayasa, Indonesia

[Dr. Anting Wulandari](#), Department of Industrial Engineering, Universitas Sultan Ageng Tirtayasa, Indonesia

[Dr. Kulsum Kulsum](#), Department of Industrial Engineering, Universitas Sultan Ageng Tirtayasa, Indonesia

[Dr. Lely Herlina](#), Department of Industrial Engineering, Universitas Sultan Ageng Tirtayasa, Indonesia

[Dr. Ade Irman Saeful Mutaqin](#), Department of Industrial Engineering, Universitas Sultan Ageng Tirtayasa, Indonesia

[Muhammad Ilham Adelino](#), Universitas Putra Indonesia YPTK, Indonesia

[Fandi Achmad](#), Telkom University, Indonesia

[Fuad Dwi Hanggara](#), Universitas Islam Negeri Maulana Malik Ibrahim, Indonesia

[Reza Fahlevi Lubis, S. Ak., CAP., AWP., CPMP](#), Universitas Nasional, Indonesia

[Angra Meta Ruswana](#), Universitas Galuh

[Nidya Wisudawati, S.T., M.T., M.Eng](#), Universitas Muhammadiyah Palembang, Indonesia

[Rurry Patradhiani, S.T., M.T.](#), Universitas Muhammadiyah Palembang, Indonesia

[Rafiqa Fijra, ST, MSc](#), Universitas Muhammadiyah Palembang, Indonesia

[Fatturroyhan Fatturroyhan](#), Universitas Darussalam Gontor, Indonesia

[Sulfikar Sallu](#), Universitas Sembilan Belas November, Indonesia

[Ika Rezvani Aprita](#), Politeknik Indonesia Venezuela, Indonesia

[Adhi Putra Satria](#), UNTAG Semarang, Indonesia

[Rosa Nikmatul Fajri](#), Universitas Alma Ata, Indonesia

[Agus Ismail](#), Universitas Mercu Buana, Indonesia

[Tania Avianda Gusman](#), Universitas Muhammadiyah Cirebon, Indonesia

[Dutho Suh Utomo](#), Universitas Mulawarman, Indonesia

[Dr. Surya Cipta Ramadhan Kete, M.Sc](#), Halu Oleo University, Indonesia

[ling Pamungkas](#), Universitas Teuku Umar, Indonesia

[Erni Krisnaningsih](#), Universitas Esa Unggul, Indonesia

[Mohammad Mi'radj Isnaini, ST., MT., Ph.D](#), Institut Teknologi Bandung, Indonesia

[Dr. Tifa Noer Amelia, SE., M.Acc](#), Perbanas Institute, Indonesia

[Dr. Andrian Haro, S.Si., M.M.](#), Universitas Negeri Jakarta, Indonesia

[Rosita Kusumawati, S.Si., M.Sc.](#), Universitas Negeri Yogyakarta, Indonesia

[Riski Arifin, S.T., M.T.](#), Universitas Syiah Kuala

[Gama Harta Nugraha Nur Rahayu](#), Universitas Pancasila, Indonesia

[Saiful Hendra, S. T., M. T.](#), Universitas Mercubuana, Indonesia

[Dina Rachmawaty, ST., MT](#), Institut Teknologi Telkom Purwokerto, Indonesia

[Nabila Nabila Noor Qisthani, ST., MT.](#), Institut Teknologi Telkom Purwokerto, Indonesia

[Anastasia Febiyani, ST., MT](#), Telkom University, Indonesia

[Dr. Irvan Setiadi Kartawiria, ST., M.Sc](#), Swiss German University, Indonesia

## Akreditasi

**SINTA** Author Subjects Affiliations Sources FAQ WCU Registration Login

**JOURNAL INDUSTRIAL SERVICES**  
UNIVERSITAS SULTAN AGENG TIRTAYASA  
P-ISSN : 24610623 <> E-ISSN : 24610631

**1.46018**  
Impact

**1415**  
Google Citations

**Sinta 2**  
Current Accreditation

Google Scholar Garuda Website Editor URL

<https://jurnal.untirta.ac.id/index.php/jiss/article/view/31507>

The screenshot shows a web browser displaying the article page for 'Integrating ergonomic intervention and digital human modelling for posture improvement in welding tasks'. The page includes a navigation menu, a user profile section for 'aniknur', and a detailed abstract. The abstract discusses musculoskeletal disorders in welding and the use of REBA and OWAS methods. The browser's taskbar at the bottom shows various application icons and the system clock.

HOME ABOUT USER HOME CATEGORIES SEARCH CURRENT ARCHIVES ANNOUNCEMENTS IN PRESS

Home > Vol 11, No 2 (2025) > Tasik

### Integrating ergonomic intervention and digital human modelling for posture improvement in welding tasks

*Sanfransyul Arung Tasik, Rahmi Maulidya, Ika Wahyu Utami, Dian Mardi Safitri, Novia Rahmawati, Anik Nur Habyba*

#### Abstract

Work-related musculoskeletal disorders (MSDs) are a persistent problem in welding, where awkward and prolonged postures elevate ergonomic risks. This study investigated two common welding postures in a heavy industrial workshop and aimed to design effective interventions by integrating traditional observational methods with digital human modeling. Ergonomic risks were first assessed using the Rapid Entire Body Assessment (REBA) and the Ovako Working Analysis System (OWAS). The REBA and OWAS analyses identified the sitting-squatting postures as very high risk, while the standing posture posed a moderate risk. Anthropometric data were applied in the 3D Static Strength Prediction Program (3DSSPP) to simulate and evaluate redesign options. The proposed adjustable workbench successfully reduced the sitting-squatting posture to a moderate risk category, whereas height modification of the small lathe provided only marginal improvements for standing posture. These findings confirm that combining observational analysis with digital simulation yields more reliable insights for ergonomic redesign. The results emphasize the need for proactive interventions to reduce MSD risks, improve worker comfort and enhance productivity in heavy industrial environments.

**USER**  
You are logged in as...  
**aniknur**  
» My Journals  
» My Profile  
» Log Out

**MENU**  
Editorial Team  
Reviewers  
Focus and Scope  
Peer Review Process  
Open Access Policy  
Author Guidelines  
Copyright Notice  
Crossmark Policy  
In Press

**REVIEW INSTRUCTIONS**  
Review Procedure (pdf)  
Review Procedure (video)

**SUBMISSION INSTRUCTIONS**

Rahmi Maulidya

<https://sinta.kemdiktisaintek.go.id/authors/profile/5987373/?view=googlescholar>

The screenshot shows the author profile page for Rahmi Maulidya on the SINTA website. The page features a navigation menu, a list of publications, and a summary section with charts for Article Quartile and Research Output. The browser's taskbar at the bottom shows various application icons and the system clock.

SINTA Author Subjects Affiliations Sources FAQ WCU Registration Login

Scopus Garuda Google Scholar RAMA

**An Integrated Order System of Prototype Parts in a Vehicle Development Activity: A Case Study**  
Authors : SM Pradipta, P Moengin, R Maulidya *Proceedings of the 7th Asia Pacific Conference on Manufacturing Systems and ...*, 2025  
2025 0 cited

**Integrating ergonomic intervention and digital human modelling for posture improvement in welding tasks**  
Authors : SA Tasik, R Maulidya, IW Utami, DM Safitri, N Rahmarati, AN Habyba *Journal Industrial Services* 11 (2), 279-289, 2025  
2025 0 cited

**Pelatihan Pembuatan Sabun Ramah Lingkungan Berbasis Eco-Enzyme di Yayasan Amal Ikhlas Mandiri Tasikmalaya**  
*Abdimas Universal* 7 (1), 223-228,

#### Summary

**Article Quartile**  
Q1: 1, Q2: 1, Q3: 2, Q4: 4

**Research Output**  
Articles: 10, Citations: 36, Cited Documents: 5, H-index: 4

	Scopus	GScholar
Article	10	51
Citation	36	81
Cited Document	5	16
H-index	4	5

Ika Wahyu Utami

<https://sinta.kemdiktisaintek.go.id/authors/profile/6861973/?view=googlescholar>

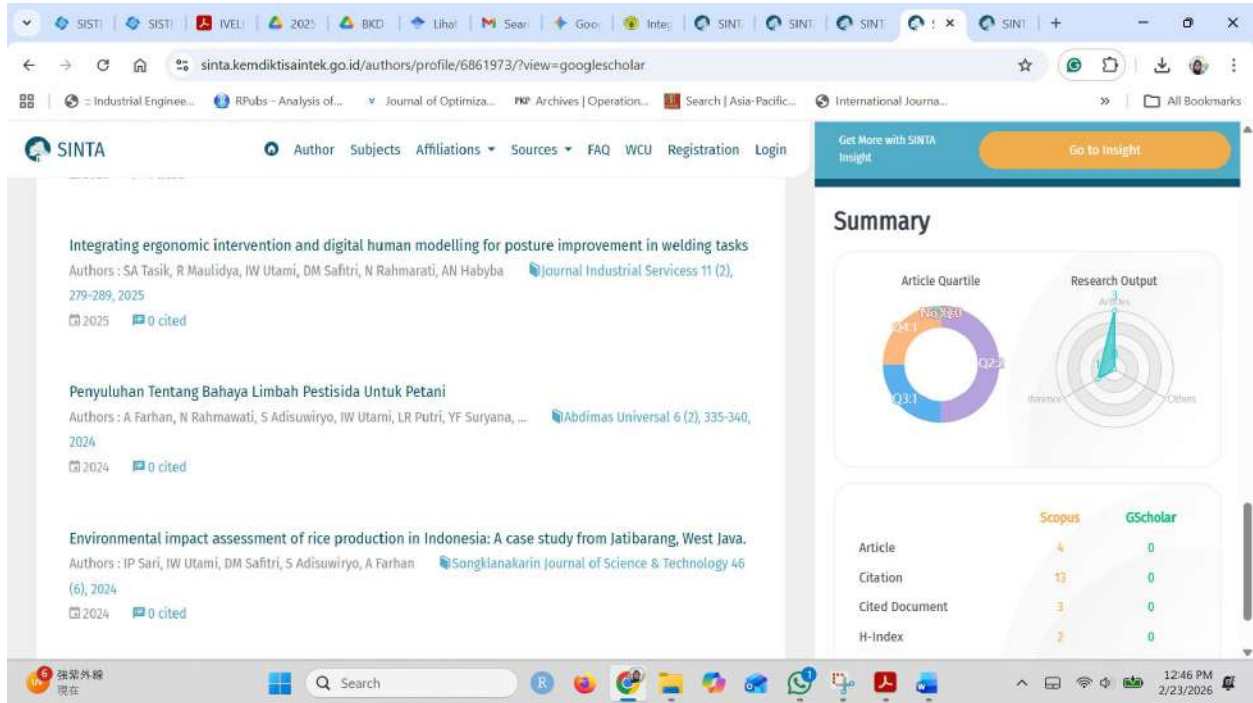

The screenshot shows the SINTA author profile for Ika Wahyu Utami. The page features a navigation bar with 'SINTA' and various menu items like 'Author', 'Subjects', and 'Affiliations'. A 'Get More with SINTA Insight' button is visible. The main content area displays three articles:

- Integrating ergonomic intervention and digital human modelling for posture improvement in welding tasks**  
Authors: SA Tasik, R Maulidya, IW Utami, DM Safitri, N Rahmarati, AN Habyba  
Journal Industrial Services 11 (2), 279-289, 2025  
0 cited
- Penyuluhan Tentang Bahaya Limbah Pesticida Untuk Petani**  
Authors: A Farhan, N Rahmawati, S Adisuwiry, IW Utami, LR Putri, YF Suryana, ...  
Abdimas Universal 6 (2), 335-340, 2024  
0 cited
- Environmental impact assessment of rice production in Indonesia: A case study from Jatibarang, West Java.**  
Authors: IP Sari, IW Utami, DM Safitri, S Adisuwiry, A Farhan  
Songklanakarin Journal of Science & Technology 46 (6), 2024  
0 cited

The 'Summary' section on the right includes an 'Article Quartile' chart (Q1, Q2, Q3, Q4) and a 'Research Output' radar chart. Below these are 'Scopus' and 'GScholar' statistics:

	Scopus	GScholar
Article	4	0
Citation	13	0
Cited Document	3	0
H-Index	2	0

Anik Nur Habyba

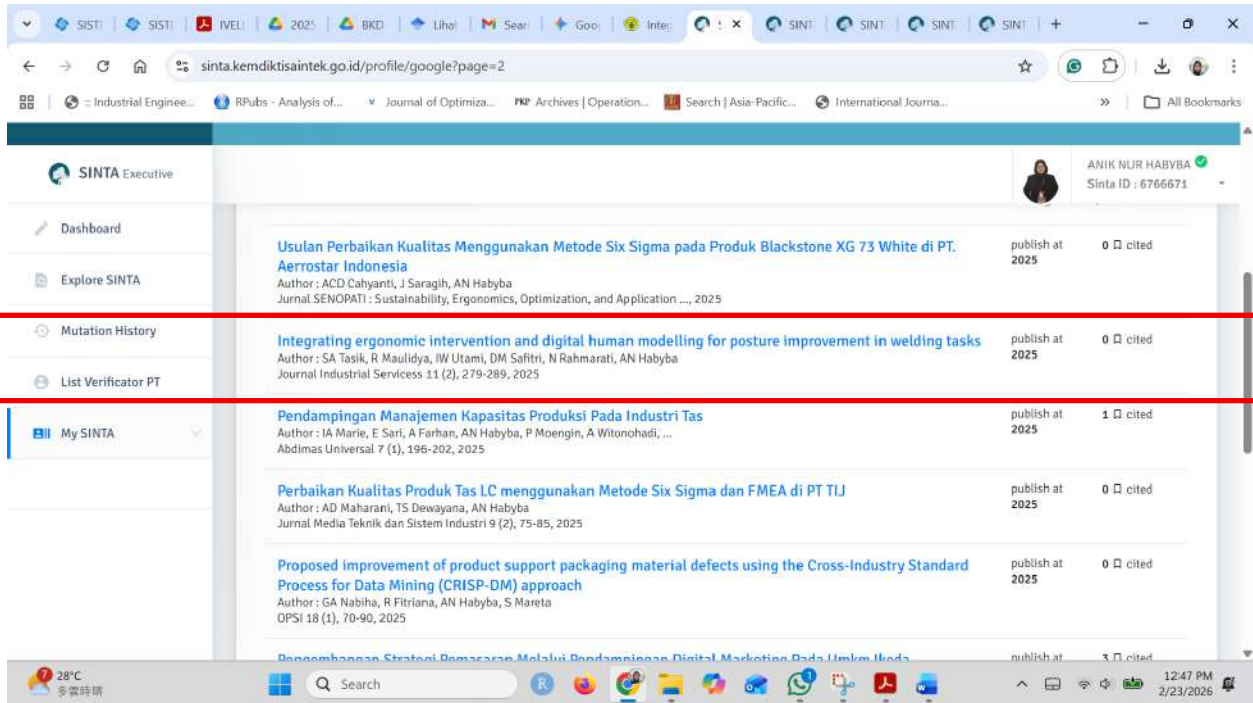

The screenshot shows the SINTA author profile for Anik Nur Habyba. The page features a navigation bar with 'SINTA Executive' and a user profile for 'ANIK NUR HABYBA' with Sinta ID: 6766671. The main content area displays a list of articles:

- Usulan Perbaikan Kualitas Menggunakan Metode Six Sigma pada Produk Blackstone XG 73 White di PT. Aerrostar Indonesia**  
Author: ACD Cahyanti, J Saragih, AN Habyba  
Jurnal SENOPATI : Sustainability, Ergonomics, Optimization, and Application ..., 2025  
publish at 2025 0 cited
- Integrating ergonomic intervention and digital human modelling for posture improvement in welding tasks**  
Author: SA Tasik, R Maulidya, IW Utami, DM Safitri, N Rahmarati, AN Habyba  
Journal Industrial Services 11 (2), 279-289, 2025  
publish at 2025 0 cited
- Pendampingan Manajemen Kapasitas Produksi Pada Industri Tas**  
Author: IA Marie, E Sari, A Farhan, AN Habyba, P Moengin, A Witonohadi, ...  
Abdimas Universal 7 (1), 196-202, 2025  
publish at 2025 1 cited
- Perbaikan Kualitas Produk Tas LC menggunakan Metode Six Sigma dan FMEA di PT TIJ**  
Author: AD Maharani, TS Dewayana, AN Habyba  
Jurnal Media Teknik dan Sistem Industri 9 (2), 75-85, 2025  
publish at 2025 0 cited
- Proposed improvement of product support packaging material defects using the Cross-Industry Standard Process for Data Mining (CRISP-DM) approach**  
Author: GA Nabaha, R Fitriana, AN Habyba, S Mareta  
OPSI 18 (1), 70-90, 2025  
publish at 2025 0 cited

The 'Mutation History' and 'List Verificator PT' menu items in the left sidebar are highlighted with a red box.



Original research article

## Integrating ergonomic intervention and digital human modelling for posture improvement in welding tasks

Sanfransyul Arung Tasik <sup>a</sup>, Rahmi Maulidya <sup>a</sup>, Ika Wahyu Utami <sup>a,\*</sup>, Dian Mardi Safitri <sup>a</sup>, Novia Rahmawati <sup>b</sup>, Anik Nur Habyba <sup>a,c</sup>

<sup>a</sup> Department of Industrial Engineering, Universitas Trisakti, Indonesia

<sup>b</sup> Study Program of Industrial Management, Collage of Vocational Studies, IPB University, Indonesia

<sup>c</sup> Department of Industrial Engineering and Management, Yuan Ze University, Taiwan

### ARTICLE INFO

#### Article history:

Received 4 March 2025

Received in revised form 9 September 2025

Accepted 13 September 2025

Published online 26 October 2025

#### Keywords:

MSDs

REBA

OWAS

Virtual human modeling

Posture improvement

#### Editor:

Bobby Kurniawan

#### Publisher's note:

The publisher remains neutral regarding jurisdictional claims in published maps and institutional affiliations, while the author(s) bear sole responsibility for the accuracy of content and any legal implications

### ABSTRACT

Work-related musculoskeletal disorders (MSDs) are a persistent problem in welding, where awkward and prolonged postures elevate ergonomic risks. This study investigated two common welding postures in a heavy industrial workshop and aimed to design effective interventions by integrating traditional observational methods with digital human modeling. Ergonomic risks were first assessed using the Rapid Entire Body Assessment (REBA) and the Ovako Working Analysis System (OWAS). The REBA and OWAS analyses identified the sitting-squatting postures as very high risk, while the standing posture posed a moderate risk. Anthropometric data were applied in the 3D Static Strength Prediction Program (3DSSPP) to simulate and evaluate redesign options. The proposed adjustable workbench successfully reduced the sitting-squatting posture to a moderate risk category, whereas height modification of the small lathe provided only marginal improvements for standing posture. These findings confirm that combining observational analysis with digital simulation yields more reliable insights for ergonomic redesign. The results emphasize the need for proactive interventions to reduce MSD risks, improve worker comfort and enhance productivity in heavy industrial environments.

## 1. Introduction

With the growth of the industrial sector, concerns about occupational safety have intensified [1]. Among these concerns, work-related musculoskeletal disorders (MSDs) remain one of the most prevalent occupational health issues globally, especially in industrial sectors involving physically demanding tasks such as welding, machining and construction. The Workplace Safety and Health Institute (WSH) reports approximately 2.78 million annual deaths due to hazardous work conditions [2]. According to the International Labor Organization (ILO), MSDs rank second among occupational diseases, with 160 million cases recorded worldwide [3].

MSDs are particularly common in construction and heavy equipment maintenance industries, where workers are exposed to repetitive motion, awkward

postures and high physical loads [4]-[7]. These ergonomic risk factors often result in long-term health issues, reduced productivity and increased compensation costs [8], [9]. Therefore, improving workplace ergonomics through systematic and evidence-based strategies has become a critical concern for employers seeking to reduce risks and optimize conditions.

Body posture assessment methods such as the Rapid Entire Body Assessment (REBA) and the Ovako Working Analysis System (OWAS) have been widely used to identify ergonomic risks and guide interventions [10], [11]. These tools provide structured frameworks to evaluate limb angles, postural stress and movement frequency, offering practical solutions to reduce MSDs [12], [13]. However, the majority of REBA applications have been concentrated in manufacturing (24.18%) and agriculture (21.98%), with limited

\*Corresponding author:

Email: [ika.wahyu@trisakti.ac.id](mailto:ika.wahyu@trisakti.ac.id)

<http://dx.doi.org/10.62870/jiss.v11i2.31507>



implementation in heavy equipment repair industries [14].

For instance, REBA and OWAS have been extensively applied in manufacturing (e.g., roof stick bending) [15] and agriculture (e.g., essential oil extraction using motion capture for posture analysis) [16]. In construction (e.g., dumper operators and construction workers), these methods have also been widely used, yet most studies mainly highlight significant MSD risks without providing proactive workstation redesign or simulation-based solutions [17]. In contrast, welding and heavy equipment maintenance tasks have received less attention and the majority of existing research remains descriptive [18].

Moreover, although some recent studies have explored the integration of REBA or OWAS with digital human modeling, virtual reality or digital twin frameworks [19], [20], these approaches are still limited. Most ergonomic studies still rely heavily on observational methods without digital simulation support, which reduces their potential for predictive modeling and proactive design optimization [21], [22], [23].

To address these gaps, this study integrates REBA and OWAS observational tools with Virtual Human Modeling (VHM) using the 3D Static Strength Prediction Program (3DSSPP) to evaluate and improve welder postures through simulation. This integrated approach offers the advantage of identifying existing risks using traditional methods while also providing a predictive framework to design and validate ergonomic interventions prior to physical implementation, thereby reducing both cost and time. This research contributes to ergonomic intervention methodologies by:

1. combining traditional and digital ergonomic assessment methods for comprehensive posture evaluation,
2. simulating spinal load distribution and evaluating design iterations before physical implementation,
3. proposing evidence-based workstation improvements tailored to welding tasks in heavy-duty settings.

Compared to studies that rely solely on observational approaches, the integrated use of REBA, OWAS, VHM and 3DSSPP minimizes observer bias, provides quantitative biomechanical validation and enables proactive workstation redesign before implementation.

## 2. Material and method

This study employs a quantitative descriptive research design, focusing on ergonomic risk assessment and intervention in industrial work environments involving manual labor tasks. The research integrates direct observational analysis, ergonomic risk evaluation and digital human modeling to identify and mitigate MSDs risks.

### 2.1. Research design and data collection

The study is structured into three main phases: initial survey, posture assessment and simulation-based ergonomic redesign. Data were collected through questionnaires, direct observations, anthropometric measurements and posture simulation software. An initial survey using the Nordic Body Map (NBM) was conducted to identify the primary sources of musculoskeletal discomfort among workers, guiding the focus of the subsequent posture assessment. Seven participants from different job categories (welding and lathing) were assessed before and after work shifts. Although only one welder recorded a substantially higher NBM score compared to other respondents, this case was selected as a critical case study. The welder's task involved repetitive and physically demanding postures, which consistently generated musculoskeletal complaints in multiple body regions. This marked difference in discomfort levels relative to other operators provided strong justification for concentrating on welding as the most ergonomically problematic task within the workshop. A critical case approach ensures that interventions designed for the highest-risk posture also provide transferable insights for less extreme conditions.

Direct observations and interviews were conducted to record key posture-related factors, including angles of the neck, trunk, legs, upper arms, forearms and wrists, load and grip factors and movement frequency. These variables were then analyzed using Rapid Entire Body Assessment (REBA) and Ovako Working Analysis System (OWAS). REBA evaluates body posture risks without requiring highly precise angle measurements. The method involves scoring two groups (Group A: neck, trunk, legs; Group B: upper limbs) and combining them into a composite risk score. This enables the identification of high-risk postures requiring intervention [24]. OWAS classifies posture risks based on back, arm, and leg positions, including load handling, and provides risk categories based on frequency and severity [25], [26].

Anthropometric measurements were used to support ergonomic redesigns. Key body dimensions (popliteal height, hip width, buttock-popliteal length, sitting and standing elbow height) were collected using both primary measurements and Indonesian anthropometric references. These data were essential for designing posture-corrective equipment tailored to workers' physical characteristics.

### 2.2. Research design and data collection

To simulate and evaluate the ergonomic impact of design modifications, the 3D Static Strength Prediction Program (3DSSPP) developed by the University of Michigan was utilized [27], [28]. By integrating REBA, OWAS, anthropometry, and virtual human modeling, this study provides a comprehensive method for ergonomic assessment and design optimization. The findings provide a foundation for implementing

ergonomic interventions to reduce the risk of MSDs in heavy-duty industrial tasks.

### 3. Results and discussions

This study investigates two welding postures commonly adopted in heavy-duty repair tasks: a sitting-squatting position (Posture 1) and a standing position (Posture 2). Each posture presents different ergonomic risks depending on the nature of the welding tasks and workspace constraints. The analysis aims to determine which posture poses a greater risk of MSDs and to propose ergonomic improvements based on the assessment results.

#### 3.1. Initial musculoskeletal discomfort assessment

To identify the primary source of musculoskeletal discomfort, a preliminary Nordic Body Map (NBM) survey was conducted before and after work shifts [29]. The NBM survey results are summarized in Table 1. Respondent 1 (a welder) scored significantly higher than others, indicating substantial discomfort across multiple body regions. In contrast, other respondents working in lathing reported significantly lower scores. These findings highlight welding as the most ergonomically problematic task in the workshop, reinforcing the need for posture-specific ergonomic analysis. Subsequent sections therefore focus on welding postures to evaluate ergonomic risks and develop targeted interventions.

#### 3.2. Ergonomic assessment of Posture 1

Posture 1 is characterized by a sitting-squatting position used during precision welding tasks as shown in Fig. 1. Observations were conducted for one hour. The REBA assessment evaluated ergonomic factors, including body angles, load handling, grip conditions and muscle activity. The assessment factors and corresponding scores are presented in Table 2.

The REBA assessment for Posture 1 yielded a Group A score of 9, derived from significant trunk flexion (30°), neck bending (31°) and an asymmetric leg position. This score increased to 10 after accounting for a 5 kg load. Group B scored 7 based on elevated upper arm and wrist angles and increased to 8 after considering coupling conditions. The combined C score was 12 and with an additional point for static muscle activity, leading to a final score of 13. The result was further validated using ErgoFellow 3.0 software in order to ensure the accuracy of the manual assessment [30], [31], which confirmed the same score. According to the REBA classification table, this score falls within the >11 range, indicating a risk level of 4, classified as very high risk [32]. The high REBA score observed in Posture 1 is consistent with previous findings in manual concrete block production, where squatting and bending postures also yielded a REBA score of 11, classified as very high risk [33]. Workers reported musculoskeletal complaints in the back, arms, wrists, calves and thighs due to prolonged static loading in similar postures.

**Table 1**  
The results of the NBM survey.

Subject	Age	Task	Total score	Category
Respondent 1	31	Welding	45	High
Respondent 2	22	Lathing	7	Low
Respondent 3	24	Lathing	11	Low
Respondent 4	35	Lathing	18	Low
Respondent 5	22	Lathing	9	Low
Respondent 6	20	Lathing	18	Low
Respondent 7	30	Lathing	13	Low

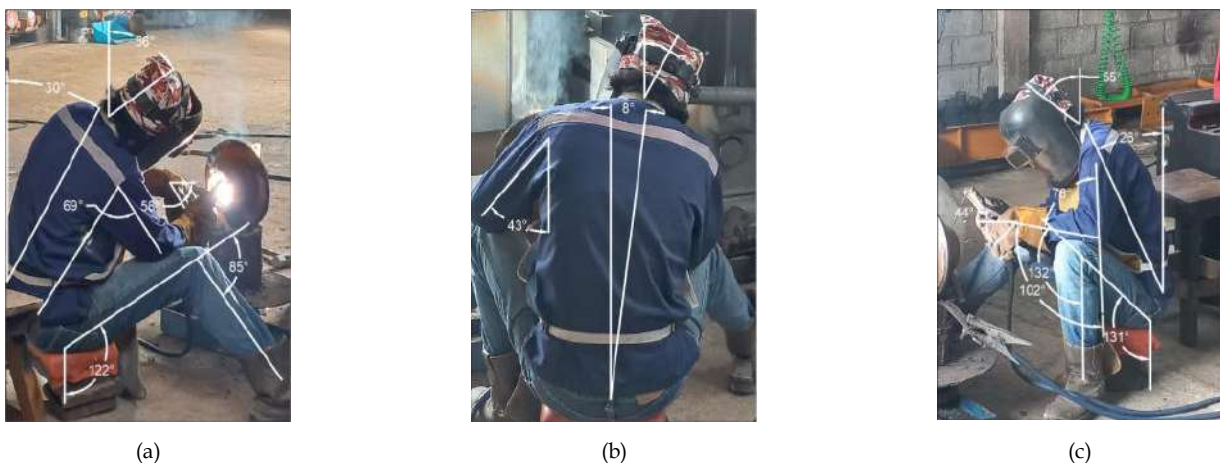

**Fig. 1.** Posture 1 from: (a) right, (b) rear, and (c) left views.

**Table 2**  
Factors assessed by REBA for Posture 1.

No.	Factors	Identification
1	Neck	Forming an angle of 56° and bending 31°
2	Trunk	Forming an angle of 30° and bending 8°
3	Legs	Forming an angle of 132° with one leg supporting the trunk
4	Load	5 kilograms or 11 lbs
5	Upper arm	Forming an angle of 69° and moving away from the trunk at an angle of 43°
6	Forearm	Forming an angle of 102°
7	Wrist	Forming an angle of 58° and the palm is turned inward
8	Coupling	The rubber on the handle is peeling off
9	Activity	Welding in a static state

**Table 3**  
Factors assessed in OWAS for posture 1.

No.	Factors	Identification
1	Back	Forming an angle of 30°
2	Arms	Both arms are under the shoulders
3	Legs	Both legs bent in a squatting position
4	Load	5 kilograms or 11 lbs



(a)



(b)



(c)

**Fig. 2.** Posture 2 (standing) from: (a) right, (b) rear, and (c) left views.

**Table 4**  
Factors assessed by REBA for Posture 2.

No.	Factors	Identification
1	Neck	Forming an angle of 30° and bending 30°
2	Trunk	Forming an angle of 4° and bending 9°
3	Legs	Both legs support the trunk
4	Load	5 kilograms or 11 lbs
5	Upper arm	Forming an angle of 11°
6	Forearm	Forming an angle of 96°
7	Wrist	Forming an angle of 18° and the palm is turned inward
8	Coupling	The rubber on the handle is peeling off
9	Activity	Welding in a static state

**Table 5**  
Factors assessed in OWAS for posture 2.

No.	Factors	Identification
1	Back	In the straight position
2	Arms	Both arms are under the shoulders
3	Legs	Standing on both feet
4	Load	5 kilograms or 11 lbs

**Table 6**  
Indonesian anthropometric data [39].

No.	Dimensions	5 <sup>th</sup>	50 <sup>th</sup>	95 <sup>th</sup>
1	Popliteal height	38	43	49
2	Hip width	28	35	43
3	Buttocks popliteal	31	40	48
4	Sitting elbow height	24	32	40
5	Standing elbow height	98	105	113

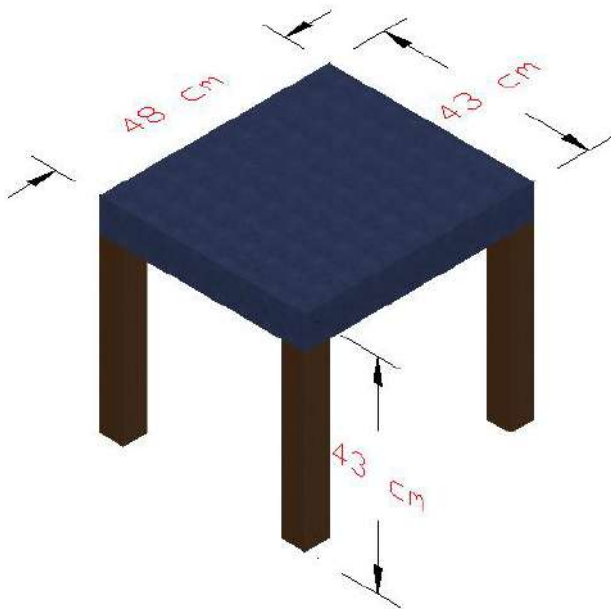

**Fig. 3.** Workbench design.

These parallels reinforce that sustained squatting-bending positions impose considerable ergonomic risks across different manual industries, validating the present assessment results. Following the REBA assessment, the OWAS method was performed to further classify postural strain. The identified OWAS assessment factors for Posture 1 are summarized in Table 3.

The OWAS analysis validated using ErgoFellow 3.0, produced a posture code of 2-1-5-1, corresponding to a risk level of 3 (moderate risk). According to the OWAS assessment table, back and leg positions were classified as high risk (scores of 3 and 4, respectively), while the arms were classified as low risk (score of 1) [32]. These results highlight that while REBA identified very high overall risk, OWAS emphasized localized high-risk areas, particularly in the lower limbs and spine. The alignment of both methods underscores the urgent need for targeted interventions, including posture adjustments and workstation redesign to mitigate long-term MSD risks.

### 3.3. Ergonomic assessment of Posture 2

Posture 2 corresponds to a standing position commonly adopted during welding tasks (

Fig. 2). This posture involves prolonged standing combined with repetitive upper-body movements, potentially leading to musculoskeletal strain. The REBA assessment for Posture 2 was conducted to evaluate

ergonomic risk factors, including body angles, load handling, grip conditions and muscle activity (Table 4).

The assessment process assigned an initial score of 6 to Group A, which evaluates the neck, trunk and legs, and a score of 3 to Group B, which focuses on the upper arm, forearm and wrist. The final C score was recorded as 6, leading to a Final REBA Score of 7. This score indicates a moderate ergonomic risk (risk level 2), suggesting that while Posture 2 does not pose an immediate danger, prolonged exposure without corrective interventions could contribute to musculoskeletal discomfort. To further evaluate postural strain in Posture 2, the OWAS was performed. The assessment focused on key ergonomic factors, including back, arm, and leg positions, as well as the load handled by welders. The identified OWAS assessment factors are summarized in Table 5.

The manual OWAS analysis assigned a posture code of 1-1-2-1, corresponding to risk level 1, which is classified as low-risk. According to the OWAS classification, risk scores by body region were back = 1 (low), arms = 1 (low) and legs = 2 (moderate) [32]. The ErgoFellow 3.0 validation confirmed identical results. This classification indicates a normal posture with no significant impact on the musculoskeletal system. The relatively low risk for Posture 2 is attributed to neutral spine alignment, balanced bilateral foot support and minimal trunk flexion, all of which reduce lumbar compression forces.

A comparison with previous literature provides additional context for interpreting the ergonomic risk classification of Posture 2 in the present study. As reported in [34], novice welders in a Malaysian technical institution exhibited an average REBA score of 9, classified as a high-risk category, primarily due to trunk flexion, neck bonding and varied lower limb positions observed during standing welding tasks.

In contrast, the standing posture assessed as Posture 2 in this study recorded a REBA score of 7, classified as moderate risk. The lower score is supported by the quantitative measurements presented in Table 4, which show minimal trunk flexion with slight bending, balanced bilateral foot support and moderate neck flexion. Upper limb angles and a light load of 5 kg further reduced physical demand. These favourable ergonomic factors collectively minimized lumbar compression forces and musculoskeletal strain, explaining the moderate risk classification compared to the higher-risk standing welding postures reported in [34].

Results from related research further indicate that even moderate-risk postures can contribute to musculoskeletal strain, when tasks are prolonged and repetitive [35]. Welders in that study exhibit high prevalence rates of lower back, shoulder and wrist pain, with significant associations between elevated REBA scores and self-reported discomfort. Additional risk factors such as long working hours and lack of physical activity exacerbated these outcomes, while protective factors included work-rest breaks and higher job satisfaction. This evidence suggests that although

Posture 2 demonstrates a reduced risk profile compared to previously reported standing welding postures, preventive ergonomic strategies remain essential to mitigate the long-term progression of work-related MSDs [36].

### 3.4. Ergonomic intervention and design evaluation

To mitigate the identified risks, a series of ergonomic interventions and design modifications was proposed and evaluated. For Posture 1, the primary target areas for posture improvement include the neck, trunk, forearms, wrists, and feet. The primary objective is to shift from a sitting-squatting to a proper sitting posture, which has been shown to reduce leg strain, minimize energy expenditure and improve blood circulation. Research suggests that working in a sitting position is preferable for tasks requiring precision and prolonged durations [37]. The seat design must allow variations in posture to accommodate movement flexibility [38].

A customized workbench was designed using Indonesian anthropometric data (Table 6) [39], ensuring comfort, safety, and ergonomic practicality for prolonged use (2–6 hours per component) (Fig. 3). The bench height is determined based on the popliteal height of P50, while width and length are designed based on shoulder width and buttocks-popliteal distance using the large percentile (P95).

A proper worktable is also necessary to compensate for height variations when working in a sitting position. Sitting elbow height and popliteal height were used as references to design an optimal table height, tested through three percentile-based experimental heights: small percentile (62 cm), middle percentile (75 cm), and large percentile (89 cm).

The 3D Static Strength Prediction Program (3DSSPP) human model simulation confirmed that a table height of 75 cm provides the most natural body positioning, as seen in Fig. 4. The final worktable dimensions are 100 cm in length and 50 cm in width, constructed from metal or steel to withstand heavy loads (Fig. 5).

After implementation, the redesigned workstation successfully reduced the REBA score to 6 (moderate risk, level 2) and the OWAS code to 1-1-1-1 (low risk, level 1). The 3DSSPP analysis validated this improvement, indicating an L4/L5 spinal load of 1789 N, which falls within the safe category. The design optimization of an excavator driver cabin in [40], which included adjustments based on anthropometric data, resulted in a reduction of REBA scores, supporting the effectiveness of this intervention.

For Posture 2, improvements focused on adjusting the height of the small lathe, a primary workspace for standing welders. Using the standing elbow height from the middle percentile (P50) of 105 cm, the small lathe was raised by 5 cm from its previous height of 100 cm. The new height of 105 cm better aligns with ergonomic requirements. The human model simulation confirmed improved posture ergonomics (Fig. 6).

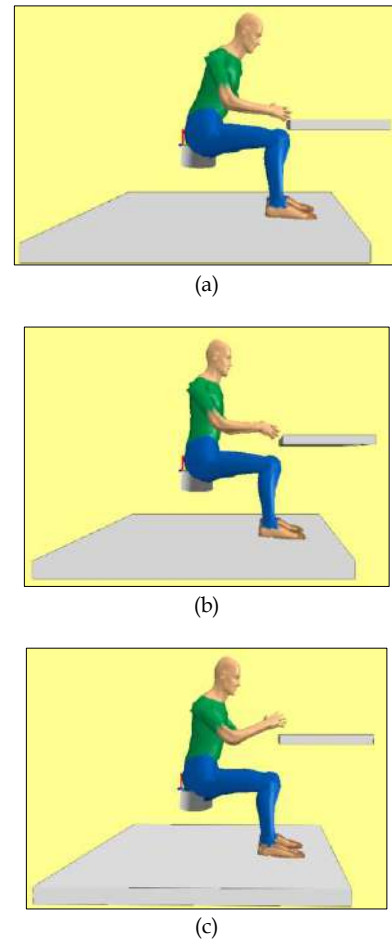

Fig. 4. Worktable height simulation: (a) 62, (b) 75 and (c) 89 cm.

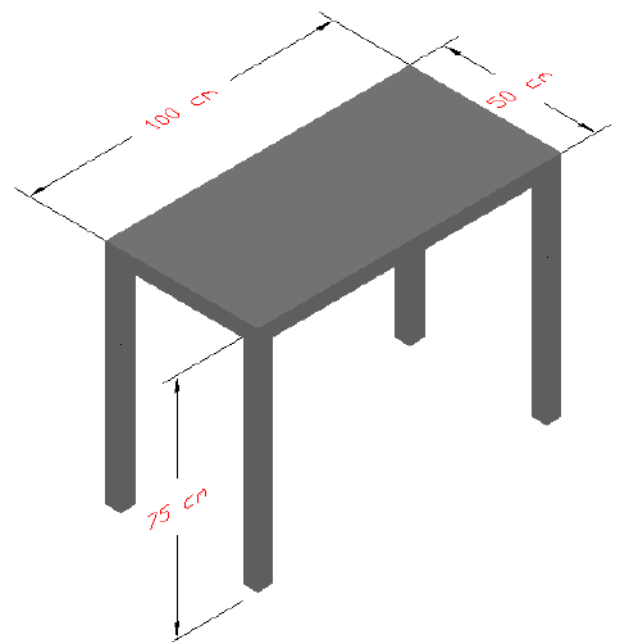

Fig. 5. Workbench design.

This adjustment resulted in a reduced REBA score of 5 (moderate risk, level 2) and the OWAS code to 1-1-2-1 (low risk, level 1). The 3DSSPP analysis validated this improvement, indicating an L4/L5 spinal load of 1100 N (112 kg), which falls within the safe category.

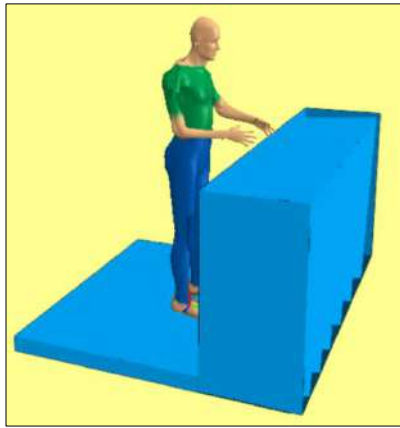

Fig. 6. Posture 2 improvement simulation.

**Table 7**  
Anthropometric data for welders.

Anthropometric data	Dimensions (cm)
Popliteal Height	47
Hip Width	52
Buttocks-popliteal	51
Sitting Elbow Height	28
Standing Elbow Height	105

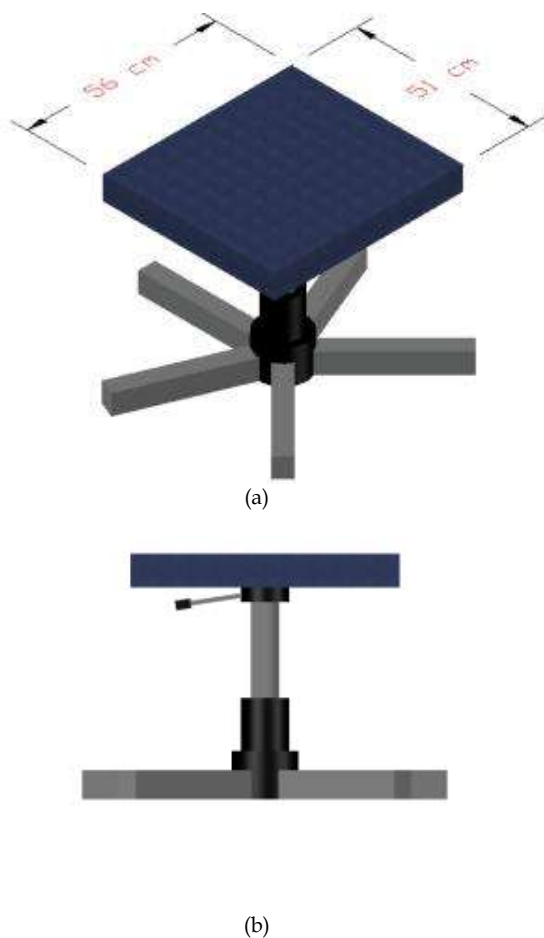

Fig. 7. Adjustable workbench for welders: (a) isometric view and (b) front view.

In addition to Indonesian anthropometric data, actual measurements of the welders were collected for better customization (Table 7). Compared to standard

Indonesian anthropometry, welders exhibited larger dimensions, particularly in popliteal height, hip width, and buttocks-popliteal distance (4 cm larger than standard data). These deviations have direct implications for workbench ergonomics, as a fixed-height bench would not accommodate the full range of body sizes, potentially increasing awkward postures and localized muscle strain. To address this, a hydraulic-adjustable bench with a height range of 38–49 cm was proposed (Fig. 7). This configuration allows each user to adjust the bench height relative to their own popliteal and elbow height, thereby maintaining optimal elbow-table angles and reducing trunk flexion.

The hydraulic mechanism enables smooth and precise vertical movement by applying fluid pressure, allowing operators to finely set the seat height with minimal effort and high accuracy, without interrupting workflow. Hydraulics systems are widely recognized for their precision and control, which are critical in adjustable benches and ergonomic seats [41]. Hydraulics were selected over mechanical systems because they provide stable positioning, durability under heavy industrial use and ease of fine-tuning, making them more reliable in demanding environments [42]. These qualities ensure that welders can quickly adapt the bench to their body dimensions and working posture, improving both comfort and safety [43].

Studies on user-furniture interaction found that ergonomic features such as adjustable seat height significantly enhance comfort and reduce muscle strain when customized to an individual’s anthropometric profile [44]. Specifically, adjustable seat height reduced thigh pressure by 8.5% over prolonged periods, while maintaining postural stability and long-term usability through dynamic positioning. Adjustable designs also support dynamic postures, which are more effective in sustaining comfort and reducing fatigue than static positions. Previous ergonomic design studies in office settings also emphasize that adjustable features are critical for enhancing user comfort and reducing strain when tailored to anthropometric data [45]. These findings reinforce the universal importance of adjustability and support the adoption of a hydraulic-adjustable design for welding workstations where tasks last several hours.

### 3.5. Preventing MSDs injuries

The primary strategy for preventing MSDs is the implementation of the redesigned workbench and seating system. This workstation was specifically developed to minimize awkward postures, reduce static loads and accommodate a wider range of worker anthropometry. To ensure maximum effectiveness, the redesigned table is integrated with a structured standard operating procedure (SOP) that combines engineering controls with participatory ergonomics [46], [47], behavioural safety [48] and continuous monitoring [49]. The proposed SOP is described as follows:

1. Early symptom reporting: workers are encouraged to report any discomfort promptly. The redesigned workbench, which incorporates adjustable height and seating support, makes it easier to identify whether improper adjustment contributes to symptoms [50]. Coupled with structured safety training and a positive reporting culture [51], early detection helps prevent minor discomfort from developing into chronic MSDs.
2. Supervisor inspection and anthropometric adjustment: supervisors are responsible for ensuring that the workbench height, seating angle and footrest are adjusted to match each worker's anthropometry. Since the redesigned workstation is adjustable, proactive fitting reduces exposure to risk factors and has been shown to lower injury rates [52], [53].
3. Corrective measures: when symptoms or postural deviations are detected, corrective actions such as posture guidance and workstation reconfiguration are implemented [54]. The redesigned table allows quick modification of surface height and tool placement, reducing forward bending and shoulder elevation, two key contributors to MSDs.
4. Monitoring the progression of symptoms: digital tools and standardized instruments are employed to track worker conditions [55]. The redesigned workbench layout provides sufficient clearance and sensor-mounting options [56], supporting continuous monitoring of posture and workload.
5. Medical examinations: when symptoms persist despite workstation adjustments, a medical assessment is conducted [51]. Data from the adjustable workstation settings assist in identifying whether specific postures or loads are linked to worker discomfort, enabling more targeted clinical interventions.
6. Documentation and continuous improvement: in which diagnosis records are systematically utilized to refine workstation design, update training modules and sustain a feedback loop for long-term prevention [57].

### 3.6. Managerial implications and future research

This study offers clear managerial implications for heavy industrial settings. The integrated use of traditional ergonomic tools with digital human modeling provides a robust methodology for identifying and proactively addressing occupational risks. The significant reduction in MSDs risk for the sitting-squatting posture, as validated by both observational and simulation methods, provides a strong, quantifiable business case for investing in ergonomic workstations. This approach shifts safety from a reactive measure to a proactive strategy that can enhance worker well-being, increase productivity, and potentially reduce compensation costs.

From an economic perspective, investment in ergonomic workstations can yield long-term savings by reducing the incidence of MSD-related injuries, thereby

lowering compensation claims, absenteeism and medical expenses. At the same time, improved comfort and safety are expected to enhance productivity and work quality, making such interventions a cost-effective strategy for industrial settings.

The validity of the simulation is supported by the well-established reliability of the 3DSSPP, developed by the University of Michigan [58]. 3DSSPP has been extensively applied in industrial ergonomics research and validated against empirical biomechanical data, particularly for predicting spinal loads, joint moments and postural stresses. Its ability to replicate realistic human postures and estimate physiological responses provides a strong justification for its use as a valid tool to support the redesign of welding workstations in this study.

A key limitation of this study is its small sample size, especially for the initial NBM survey and anthropometric data collection. Future research should expand the study to a larger population and other industrial sectors to validate the generalizability of these findings. It would also be valuable to conduct a longitudinal study to measure the long-term impact of these ergonomic interventions on worker health and productivity. Beyond these methodological extensions, future studies may also explore advanced technological integrations such as wearable posture sensors and digital monitoring systems, which would enable real-time risk detection, proactive intervention and further optimization of ergonomic practices in dynamic industrial settings.

## 4. Conclusions

This study examined the persistent ergonomic risks associated with welding activities, where specific postures were identified as contributing significantly to musculoskeletal discomfort. By applying both observational and digital simulation methods, the research identified the source of ergonomic strain and proposed evidence-based solutions. The redesign of the workstation demonstrated the value of anthropometry-driven modifications, enabling safer postures through an adjustable workbench and improved seating. For standing tasks, height adjustments of equipment offered measurable improvements in postural safety, showing that relatively simple engineering controls can yield meaningful ergonomic benefits. Beyond technical modifications, this study emphasized the integration of ergonomic interventions within a structured prevention framework. The proposed SOP, covering early symptom reporting, supervisor-led workstation adjustments, corrective actions, systematic monitoring, medical referral and continuous documentation, ensures that risk reduction is sustained through organizational practices.

From a managerial perspective, these findings demonstrate that proactive ergonomic investment reduces MSDs, enhances worker health and lowers costs related to injury claims.

Future research should validate these results with larger-scale data while exploring the integration of wearable posture sensors and digital monitoring for early detection and prevention.

### CRedit author statement

**Sanfransyul Arung Tasik:** Data Curation, Formal Analysis, Writing – Original Draft. **Rahmi Maulidya:** Conceptualization, Methodology, Supervision, Validation, Writing – Review & Editing. **Ika Wahyu Utami:** Conceptualization, Supervision, Validation, Writing – Review, Editing & Revision. **Dian Mardi Safitri, Novia Rahmawati:** Validation, Writing – Review & Editing. **Anik Nur Habyba:** Literature Review, Supporting Analysis, Writing – Review.

### Acknowledgement

The authors would like to express their gratitude to the welding workshop staff for their cooperation during field data collection. Special appreciation is extended to Universitas Trisakti for providing academic and administrative support throughout this research. The constructive feedback from reviewers also contributed significantly to improving the quality of this manuscript.

### Disclosure statement

The authors declare no conflicts of interest.

### Funding statement

The study was conducted independently without external financial support.

### Data availability statement

The authors confirm that the data supporting the findings of this study are available within the article or its supplementary materials.

### AI usage statement

This manuscript utilizes generative AI and AI-assisted tools to improve readability and language. All AI-generated content has been reviewed and edited by the authors to ensure accuracy and scientific integrity. The authors take full responsibility for the content and conclusions of this work and disclose the use of AI to maintain transparency and comply with publisher guidelines.

### References

- [1] M. Z. Muktar, S. B. Shamsudin, K. A. Lukman, and M. S. Jeffree, "Assessment of Ergonomic Risk Levels and Working Performance of Pre-cast Construction Workers in Sabah," *Malaysian Journal of Public Health Medicine*, vol. 17, no. 2, pp. 151–158, 2017.
- [2] P. H. Jukka, T. Tan, and B. Kiat, "Global Estimates of Occupational Accidents and Work-Related Illnesses 2017," Workplace Safety and Health Institute, Singapore, Sep. 2017.
- [3] J. Park, Y. Kim, and B. Han, "Work Sectors with High Risk for Work-Related Musculoskeletal Disorders in Korean Men and Women," *Safety and Health at Work*, vol. 9, no. 1, pp. 75–78, Mar. 2018, doi: [10.1016/j.shaw.2017.06.005](https://doi.org/10.1016/j.shaw.2017.06.005).
- [4] M. F. Antwi-Afari, H. Li, D. J. Edwards, E. A. Pärn, J. Seo, and A. Y. L. Wong, "Biomechanical Analysis of Risk Factors for Work-Related Musculoskeletal Disorders during Repetitive Lifting Task in Construction Workers," *Automation in Construction*, vol. 83, pp. 41–47, Nov. 2017, doi: [10.1016/j.autcon.2017.07.007](https://doi.org/10.1016/j.autcon.2017.07.007).
- [5] M. S. Rahman and J. Sakamoto, "The Risk Factors for the Prevalence of Work-Related Musculoskeletal Disorders among Construction Workers: A Review," *Research Expansion Alliance (REA)*, Jun. 01, 2024, doi: [10.22105/jarie.2023.413676.1561](https://doi.org/10.22105/jarie.2023.413676.1561).
- [6] S. Kim, M. A. Nussbaum, and B. Jia, "Low Back Injury Risks during Construction with Prefabricated (Panelised) Walls: Effects of Task and Design Factors," *Ergonomics*, vol. 54, no. 1, pp. 60–71, Jan. 2011, doi: [10.1080/00140139.2010.535024](https://doi.org/10.1080/00140139.2010.535024).
- [7] S. Bulduk, E. Ö. Bulduk, and T. Süren, "Reduction of Work-Related Musculoskeletal Risk Factors Following Ergonomics Education of Sewing Machine Operators," *International Journal of Occupational Safety and Ergonomics*, vol. 23, no. 3, pp. 347–352, Jul. 2017, doi: [10.1080/10803548.2016.1262321](https://doi.org/10.1080/10803548.2016.1262321).
- [8] K. Wong and A. H. S. Chan, "Emerging Issues in Occupational Safety and Health," *International Journal of Environmental Research and Public Health*, vol. 15, no. 12, p. 2897, Dec. 18, 2018, doi: [10.3390/ijerph15122897](https://doi.org/10.3390/ijerph15122897).
- [9] N. D. Nath, R. Akhavian, and A. H. Behzadan, "Ergonomic Analysis of Construction Worker's Body Postures Using Wearable Mobile Sensors," *Applied Ergonomics*, vol. 62, pp. 107–117, Jul. 2017, doi: [10.1016/j.apergo.2017.02.007](https://doi.org/10.1016/j.apergo.2017.02.007).
- [10] D. Kee, "Systematic Comparison of OWAS, RULA, and REBA Based on a Literature Review," *International Journal of Environmental Research and Public Health*, vol. 19, no. 1, p. 595, Jan. 01, 2022, doi: [10.3390/ijerph19010595](https://doi.org/10.3390/ijerph19010595).
- [11] D. Kee, "Comparison of OWAS, RULA and REBA for Assessing Potential Work-Related Musculoskeletal Disorders," *International Journal of Industrial Ergonomics*, vol. 83, p. 103140, May 2021, doi: [10.1016/j.ergon.2021.103140](https://doi.org/10.1016/j.ergon.2021.103140).
- [12] M. Gómez-Galán, J. Pérez-Alonso, Á.-J. Callejón-Ferre, and J. López-Martínez, "Musculoskeletal Disorders: OWAS Review," *Industrial Health*, vol. 55, no. 4, pp. 314–337, 2017.
- [13] K. Enez and S. S. Nalbantoğlu, "Comparison of Ergonomic Risk Assessment Outputs from OWAS and REBA in Forestry Timber Harvesting," *International Journal of Industrial Ergonomics*, vol. 70, pp. 51–57, Mar. 2019, doi: [10.1016/j.ergon.2019.01.009](https://doi.org/10.1016/j.ergon.2019.01.009).
- [14] M. Hita-Gutiérrez, M. Gómez-Galán, M. Díaz-Pérez, and Á. J. Callejón-Ferre, "An Overview of REBA Method

- Applications in the World,” *International Journal of Environmental Research and Public Health*, vol. 17, no. 8, p. 2635, Apr. 02, 2020, doi: [10.3390/ijerph17082635](https://doi.org/10.3390/ijerph17082635).
- [15] M. Joshi, V. Deshpande, and H. Shukla, “The Investigation of Ergonomic and Energy Intervention in Roof Sticks Bending Facility,” *International Journal of Mechanical and Production Engineering Research and Development*, vol. 9, no. Special Issue, pp. 220–225, 2019.
- [16] G. G. Reyes-Zárate, “A Digital REBA System Based on Kinect and Its Benefits for Ergonomic Assessment,” in *Smart Innovation, Systems and Technologies*, 2024, pp. 3–11, doi: [10.1007/978-981-99-7210-4\\_1](https://doi.org/10.1007/978-981-99-7210-4_1).
- [17] B. M. Kunar, M. Aruna, and M. B. Kar, “Postural Analysis of Dumper Operators and Construction Workers – A Case Study,” *Journal of Mines, Metals and Fuels*, vol. 69, no. 6, pp. 180–185, 2021, doi: [10.18311/jmmf/2021/28525](https://doi.org/10.18311/jmmf/2021/28525).
- [18] F. Colombo, “Ergonomia e Organizzazione del Lavoro,” *Rivista Italiana della Saldatura*, vol. 58, no. 6, pp. 817–822, 2006.
- [19] M. Caterino, M. Rinaldi, and M. Fera, “Digital Ergonomics: An Evaluation Framework for the Ergonomic Risk Assessment of Heterogeneous Workers,” *International Journal of Computer Integrated Manufacturing*, vol. 36, no. 2, pp. 239–259, 2023, doi: [10.1080/0951192X.2022.2090023](https://doi.org/10.1080/0951192X.2022.2090023).
- [20] J. Zhong, V. Weistroffer, P. Maurice, C. Andriot, and F. Colas, “Interacting with a Torque-Controlled Virtual Human in Virtual Reality for Ergonomics Studies,” in *Proceedings - 2022 IEEE Conference on Virtual Reality and 3D User Interfaces Abstracts and Workshops, VRW 2022*, 2022, pp. 678–679, doi: [10.1109/VRW55335.2022.00190](https://doi.org/10.1109/VRW55335.2022.00190).
- [21] J. Seo, K. Yin, and S. Lee, “Automated Postural Ergonomic Assessment Using a Computer Vision-Based Posture Classification,” in *Construction Research Congress 2016: Old and New Construction Technologies Converge in Historic San Juan - Proceedings of the 2016 Construction Research Congress, CRC 2016*, 2016, pp. 809–818, doi: [10.1061/9780784479827.082](https://doi.org/10.1061/9780784479827.082).
- [22] L. Dulina, M. Kramárov, M. Krajčovič, and D. Plinta, “Ergonomic Analysis and the Tracking Systems,” in *Ergonomics For People With Disabilities: Design For Accessibility*, 2018, pp. 135–144, doi: [10.2478/9783110617832-011](https://doi.org/10.2478/9783110617832-011).
- [23] A. Golabchi, S. Han, A. R. Fayek, and S. Abourizk, “Stochastic Modeling for Assessment of Human Perception and Motion Sensing Errors in Ergonomic Analysis,” *Journal of Computing in Civil Engineering*, vol. 31, no. 4, 2017, doi: [10.1061/\(ASCE\)CP.1943-5487.0000655](https://doi.org/10.1061/(ASCE)CP.1943-5487.0000655).
- [24] S. Hignett and L. McAtamney, “Rapid Entire Body Assessment (REBA),” *Applied Ergonomics*, vol. 31, no. 2, pp. 201–205, Apr. 2000, doi: [10.1016/S0003-6870\(99\)00039-3](https://doi.org/10.1016/S0003-6870(99)00039-3).
- [25] B. Gajšek, A. Draghici, M. E. Boatca, A. Gaureanu, and D. Robescu, “Linking the Use of Ergonomics Methods to Workplace Social Sustainability: The Ovako Working Posture Assessment System and Rapid Entire Body Assessment Method,” *Sustainability (Switzerland)*, vol. 14, no. 7, Apr. 2022, doi: [10.3390/su14074301](https://doi.org/10.3390/su14074301).
- [26] O. Karhu, P. Kansil, and I. Kuorinka, “Correcting Working Postures in Industry: A Practical Method for Analysis,” *Applied Ergonomics*, vol. 8, no. 4, pp. 199–201, Dec. 1977.
- [27] N. Sarter, “3DSSPP: Background Information,” 2020. [Online]. Available: <https://c4e.engin.umich.edu/tools-services/3dsspp-software/3dsspp-background-information/>
- [28] A. D. Hall, N. J. La Delfa, C. Loma, and J. R. Potvin, “A Comparison Between Measured Female Linear Arm Strengths and Estimates from the 3D Static Strength Prediction Program (3DSSPP),” *Applied Ergonomics*, vol. 94, p. 103415, Jul. 2021, doi: [10.1016/j.apergo.2021.103415](https://doi.org/10.1016/j.apergo.2021.103415).
- [29] D. M. Safitri, N. C. Rizani, and F. Alexander, “Perancangan Fasilitas Kerja yang Ergonomis Stasiun Perakitan di PT X untuk Mengurangi Risiko Work-Related Musculoskeletal Disorders,” *J@TI Undip*, vol. 3, no. 3, pp. 184–190, 2008.
- [30] FBFSistemas, “ErgoFellow 3.0,” [Online]. Available: <https://www.fbfsistemas.com/ergonomics.html>
- [31] C. P. Dewangan and A. K. Singh, “Ergonomic Study and Design of the Pulpit of a Wire Rod Mill at an Integrated Steel Plant,” *Journal of Industrial Engineering*, vol. 2015, pp. 1–11, Feb. 2015, doi: [10.1155/2015/412921](https://doi.org/10.1155/2015/412921).
- [32] Tarwaka, *Ergonomi Industri Dasar-Dasar Pengetahuan Ergonomi dan Aplikasi di Tempat Kerja: Penilaian Risiko Gangguan Sistem Muskuloskeletal*, 2nd ed. Surakarta: Harapan Press, 2019.
- [33] L. Widodo, S. Ariyanti, and A. Jason, “Ergonomic Intervention to Improve the Productivity of Brick Press Tool in Small and Medium Enterprise (SME) Akheng Kobar,” in *IOP Conference Series: Materials Science and Engineering*, vol. 847, no. 1, May 2020, p. 012057, doi: [10.1088/1757-899X/847/1/012057](https://doi.org/10.1088/1757-899X/847/1/012057).
- [34] K. F. Bin Salleh, S. M. Fadzil, and M. Y. M. Daud, “Ergonomic Posture Assessment Approaches for New Welder: A Study in Technical Institution,” *Jurnal Kejuruteraan*, vol. 35, no. 5, pp. 1045–1054, Sep. 2023, doi: [10.17576/jkukm-2023-35\(5\)-06](https://doi.org/10.17576/jkukm-2023-35(5)-06).
- [35] C. Elvis, N. France, and E. Patience, “Risk Factors for Work-Related Musculoskeletal Disorders among Welders in the Informal Sector under Resource Constrained Settings,” *Work*, vol. 72, no. 1, pp. 239–252, 2022, doi: [10.3233/WOR-205275](https://doi.org/10.3233/WOR-205275).
- [36] A. J. Van Der Beek, J. T. Dennerlein, M. A. Huysmans, S. E. Mathiassen, A. Burdorf, W. van Mechelen, J. H. van Dieën, M. H. W. Frings-Dresen, E. A. Holtermann, K. Janwantanakul, A. van der Molen, D. Rempel, L. Straker, K. Walker-Bone, and P. Coenen, “A Research Framework for the Development and Implementation of Interventions Preventing Work-Related Musculoskeletal Disorders,” *Scandinavian Journal of Work, Environment & Health*, vol. 43, no. 6, pp. 526–539, 2017, doi: [10.5271/sjweh.3671](https://doi.org/10.5271/sjweh.3671).
- [37] E. Grandjean, *Fitting the Task to the Man*, 4th ed. London: Taylor & Francis Inc, 1993.
- [38] S. Pheasant, *Body Space, Anthropometry, Ergonomics and Design*. London: Taylor & Francis Inc, 1998.
- [39] Antropometri Indonesia, “Rekap Data Antropometri Indonesia,” [Online]. Available:

- [https://antropometriindonesia.org/index.php/detail/artikel/4/10/data\\_antropometri](https://antropometriindonesia.org/index.php/detail/artikel/4/10/data_antropometri)
- [40] K. Koushik Balaji and M. S. Alphin, "Computer-Aided Human Factors Analysis of the Industrial Vehicle Driver Cabin to Improve Occupational Health," *International Journal of Injury Control and Safety Promotion*, vol. 23, no. 3, pp. 240–248, 2016, doi: [10.1080/17457300.2014.992351](https://doi.org/10.1080/17457300.2014.992351).
- [41] P. Dudziński and A. Skurjat, "Impact of Hydraulic System Stiffness on Its Energy Losses and Its Efficiency in Positioning Mechanical Systems," *Energies*, vol. 15, no. 1, p. 294, 2022, doi: [10.3390/en15010294](https://doi.org/10.3390/en15010294).
- [42] A. Vacca and G. Franzoni, *Hydraulic Fluid Power: Fundamentals, Applications, and Circuit Design*. 2021. [Online]. Available: <https://www.scopus.com/inward/record.uri?eid=2-s2.0-85126554373&partnerID=40&md5=87acde350bc3525e7d4dae5fc55d0498>
- [43] J. M. N. Silva, A. L. F. Correia, R. M. C. S. Almeida, and M. A. P. Vaz, "Evaluation of the Ergonomic Changes Made in the Presses Sector in a Metallurgical Industry," in *Occupational Safety and Hygiene - Proceedings of the International Symposium on Occupational Safety and Hygiene, SHO 2013*, 2013, pp. 347–350, doi: [10.1201/b14391-72](https://doi.org/10.1201/b14391-72).
- [44] M. Gao, "Analyze the Physical Interaction Between the User and the Furniture Design to Optimize Comfort and Functionality," *MCB Molecular and Cellular Biomechanics*, vol. 21, no. 2, 2024, doi: [10.62617/mcb457](https://doi.org/10.62617/mcb457).
- [45] F. T. Basaria, M. K. Perdana, C. Harito, V. Puspita, R. Shafira, and S. A. Salsabilla, "Sustainable and Ergonomic Office Chair: ROSA Insights for Improved Workplace Health," in *IOP Conference Series: Earth and Environmental Science*, vol. 1488, no. 1, 2025, p. 012056, doi: [10.1088/1755-1315/1488/1/012056](https://doi.org/10.1088/1755-1315/1488/1/012056).
- [46] A. Choobineh, M. Motamedzade, M. Kazemi, A. Moghimbeigi, A. H. Pahlavian, and M. R. Azmoon, "A Multilayered Ergonomic Intervention Program on Reducing Musculoskeletal Disorders in an Industrial Complex—A Dynamic Participatory Approach," *International Journal of Industrial Ergonomics*, vol. 86, p. 103221, 2021, doi: [10.1016/j.ergon.2021.103221](https://doi.org/10.1016/j.ergon.2021.103221).
- [47] E. M. Capodaglio, "Participatory Ergonomics for the Reduction of Musculoskeletal Exposure of Maintenance Workers," *International Journal of Occupational Safety and Ergonomics*, vol. 28, no. 1, pp. 376–386, 2022, doi: [10.1080/10803548.2020.1761670](https://doi.org/10.1080/10803548.2020.1761670).
- [48] R. W. Bunch, "An Integrated Ergo-Behavioral Approach to Prevention of Musculoskeletal Disorders (MSDs)," in *ASSE Professional Development Conference and Exposition 2004*, 2004. [Online]. Available: <https://www.scopus.com/inward/record.uri?eid=2-s2.0-85058445175&partnerID=40&md5=d7d2b309c082b5ac413c04f0b45404f4>
- [49] J. O. Adibeli, Y.-K. Liu, N. J. Awodi, A. K. Chepkwony, and A. Ayodeji, "Ergonomic Analysis in Nuclear Decommissioning: A Comprehensive Path Planning Strategy for Workers Well-Being," *Nuclear Engineering and Design*, vol. 426, p. 113409, 2024, doi: [10.1016/j.nucengdes.2024.113409](https://doi.org/10.1016/j.nucengdes.2024.113409).
- [50] C. O. Soares, B. F. Pereira, M. V. P. Gomes, L. P. Marcondes, F. C. Gomes, and J. S. De Melo-Neto, "Preventive Factors Against Work-Related Musculoskeletal Disorders: Narrative Review," *Revista Brasileira de Medicina do Trabalho*, vol. 17, no. 3, pp. 415–430, 2019, doi: [10.5327/Z1679443520190360](https://doi.org/10.5327/Z1679443520190360).
- [51] M. Kyung, S.-J. Lee, L. M. Wagner, C. Harris-Adamson, and O. Hong, "Factors Associated With Reporting Attitudes of Work-Related Musculoskeletal Disorders Among Direct Care Workers in South Korea," *Workplace Health & Safety*, vol. 72, no. 8, pp. 345–353, 2024, doi: [10.1177/21650799241247078](https://doi.org/10.1177/21650799241247078).
- [52] W. S. Shaw, M. M. Robertson, R. K. McLellan, S. Verma, and G. Pransky, "A Controlled Case Study of Supervisor Training to Optimize Response to Injury in the Food Processing Industry," *Work*, vol. 26, no. 2, pp. 107–114, 2006. [Online]. Available: <https://www.scopus.com/inward/record.uri?eid=2-s2.0-33645305458&partnerID=40&md5=179e3822c9d5ee24d4fc640b8b3e317b>
- [53] D. C. Cole, S. Hogg-Johnson, M. Manno, S. Ibrahim, R. P. Wells, and S. E. Ferrier, "Reducing Musculoskeletal Burden Through Ergonomic Program Implementation in a Large Newspaper," *International Archives of Occupational and Environmental Health*, vol. 80, no. 2, pp. 98–108, 2006, doi: [10.1007/s00420-006-0107-6](https://doi.org/10.1007/s00420-006-0107-6).
- [54] X. Jin, J. Wang, J. Liu, W. Li, L. Zhang, Y. Wang, and Y. Zhang, "Ergonomic Interventions to Improve Musculoskeletal Disorders Among Vehicle Assembly Workers: A One-Year Longitudinal Study," *BMC Public Health*, vol. 25, no. 1, p. 21798, 2025, doi: [10.1186/s12889-025-21798-1](https://doi.org/10.1186/s12889-025-21798-1).
- [55] C. Lanhers, B. Pereira, G. Garde, C. Maublant, F. Dutheil, and E. Coudeyre, "Evaluation of 'I-Preventive': A Digital Preventive Tool for Musculoskeletal Disorders in Computer Workers—A Pilot Cluster Randomised Trial," *BMJ Open*, vol. 6, no. 9, p. e011304, 2016, doi: [10.1136/BMJOPEN-2016-011304](https://doi.org/10.1136/BMJOPEN-2016-011304).
- [56] A. Greco, M. Caterino, M. Fera, and S. Gerbino, "Digital Twin for Monitoring Ergonomics During Manufacturing Production," *Applied Sciences (Switzerland)*, vol. 10, no. 21, p. 7758, 2020, doi: [10.3390/app10217758](https://doi.org/10.3390/app10217758).
- [57] J. Oakman and W. Macdonald, "The APHIRM Toolkit: An Evidence-Based System for Workplace MSD Risk Management," *BMC Musculoskeletal Disorders*, vol. 20, no. 1, p. 504, 2019, doi: [10.1186/s12891-019-2828-1](https://doi.org/10.1186/s12891-019-2828-1).
- [58] N. Sarter, "3DSSPP: Background Information," [Online]. Available: [https://c4e.engin.umich.edu/tools-services/3dsspp-software/3dsspp-background-information/?utm\\_source=chatgpt.com](https://c4e.engin.umich.edu/tools-services/3dsspp-software/3dsspp-background-information/?utm_source=chatgpt.com)

## Author information



**Sanfransyul Arung Tasik** received his bachelor's degree in Industrial Engineering from Universitas Trisakti, Indonesia. His research interests include ergonomics and digital human modelling.



**Rahmi Maulidya** is a lecturer in the Department of Industrial Engineering, Universitas Trisakti, Indonesia. She earned her doctoral degree in Industrial Engineering from Institut Teknologi Bandung, Indonesia. Her research interests include production scheduling, supply chain management, lean manufacturing and sustainable product-service systems.



**Ika Wahyu Utami** is a Junior Lecturer in the Department of Industrial Engineering, Universitas Trisakti, Indonesia. She received her master's degree in Earth Sciences from National Central University, Taiwan. Her research interests include geophysics, environmental studies, ergonomics and IoT-based instrumentation.



**Dian Mardi Safitri** is a researcher in industrial ergonomics and safety, associated with the Center of Excellence for Ergonomics, Occupational Health and Safety at Universitas Trisakti. She completed her doctoral degree in Industrial Engineering from Universitas Indonesia, focusing on advancing knowledge and practices within her field of expertise.



**Novia Rahmawati** is a Lecturer in the Study Program of Industrial Management, College of Vocational Studies, IPB University, Indonesia. She received her master's degrees in industrial engineering from Institut Teknologi Bandung and from National Taiwan University of Science and Technology (NTUST), Taiwan. Her research interests include ergonomics, usability evaluation, human-computer interaction, and supply chain management.



**Anik Nur Habyba** is a lecturer in the Department of Industrial Engineering, Universitas Trisakti, Indonesia. Her research interests are in Kansei Engineering, Data Mining, Quality Engineering, Applied Statistics, and Industrial Management. She is currently a PhD student at the Department of Industrial Engineering and Management, Yuan Ze University, Taiwan. She can be reached at [anik@trisakti.ac.id](mailto:anik@trisakti.ac.id) and [s1148904@mail.yzu.edu.tw](mailto:s1148904@mail.yzu.edu.tw).

# TURNITIN TASIK ET.AL - 15 JUNI 2026

*by* Dian Mardi Safitri

---

**Submission date:** 15-Jun-2026 01:55PM (UTC+0700)

**Submission ID:** 2983547801

**File name:** 31507-96308-1-PB\_3\_.pdf (677.73K)

**Word count:** 7389

**Character count:** 43596



## Original research article

## Integrating ergonomic intervention and digital human modelling for posture improvement in welding tasks

Sanfransyul Arung Tasik<sup>a</sup>, Rahmi Maulidya<sup>a</sup>, Ika Wahyu Utami<sup>a,\*</sup>, Dian Mardi Safitri<sup>a</sup>, Novia Rahmawati<sup>b</sup>, Anik Nur Habyba<sup>a,c</sup>

<sup>a</sup> Department of Industrial Engineering, Universitas Trisakti, Indonesia

<sup>b</sup> Study Program of Industrial Management, Collage of Vocational Studies, IPB University, Indonesia

<sup>c</sup> Department of Industrial Engineering and Management, Yuan Ze University, Taiwan

**ARTICLE INFO****Article history:**

Received 4 March 2025

Received in revised form 9 September 2025

Accepted 13 September 2025

Published online 26 October 2025

**Keywords:**

MSDs

REBA

OWAS

Virtual human modeling

Posture improvement

**Editor:**

Bobby Kurniawan

**Publisher's note:**

The publisher remains neutral regarding jurisdictional claims in published maps and institutional affiliations, while the author(s) bear sole responsibility for the accuracy of content and any legal implications

**ABSTRACT**

Work-related musculoskeletal disorders (MSDs) are a persistent problem in welding, where awkward and prolonged postures elevate ergonomic risks. This study investigated two common welding postures in a heavy industrial workshop and aimed to design effective interventions by integrating traditional observational methods with digital human modeling. Ergonomic risks were first assessed using the Rapid Entire Body Assessment (REBA) and the Ovako Working Analysis System (OWAS). The REBA and OWAS analyses identified the sitting-squatting postures as very high risk, while the standing posture posed a moderate risk. Anthropometric data were applied in the 3D Static Strength Prediction Program (3DSSPP) to simulate and evaluate redesign options. The proposed adjustable workbench successfully reduced the sitting-squatting posture to a moderate risk category, whereas height modification of the small lathe provided only marginal improvements for standing posture. These findings confirm that combining observational analysis with digital simulation yields more reliable insights for ergonomic redesign. The results emphasize the need for proactive interventions to reduce MSD risks, improve worker comfort and enhance productivity in heavy industrial environments.

### 1. Introduction

With the growth of the industrial sector, concerns about occupational safety have intensified [1]. Among these concerns, work-related musculoskeletal disorders (MSDs) remain one of the most prevalent occupational health issues globally, especially in industrial sectors involving physically demanding tasks such as welding, machining and construction. The Workplace Safety and Health Institute (WSH) reports approximately 2.78 million annual deaths due to hazardous work conditions [2]. According to the International Labor Organization (ILO), MSDs rank second among occupational diseases, with 160 million cases recorded worldwide [3].

MSDs are particularly common in construction and heavy equipment maintenance industries, where workers are exposed to repetitive motion, awkward

postures and high physical loads [4]-[7]. These ergonomic risk factors often result in long-term health issues, reduced productivity and increased compensation costs [8], [9]. Therefore, improving workplace ergonomics through systematic and evidence-based strategies has become a critical concern for employers seeking to reduce risks and optimize conditions.

Body posture assessment methods such as the Rapid Entire Body Assessment (REBA) and the Ovako Working Analysis System (OWAS) have been widely used to identify ergonomic risks and guide interventions [10], [11]. These tools provide structured frameworks to evaluate limb angles, postural stress and movement frequency, offering practical solutions to reduce MSDs [12], [13]. However, the majority of REBA applications have been concentrated in manufacturing (24.18%) and agriculture (21.98%), with limited

\*Corresponding author:

Email: [ika.wahyu@trisakti.ac.id](mailto:ika.wahyu@trisakti.ac.id)

<http://dx.doi.org/10.62870/jiss.v11i2.31507>

Journal Industrial Servicess is licensed under a Creative Commons Attribution-ShareAlike 4.0 International License (CC BY-SA).



implementation in heavy equipment repair industries [14].

For instance, REBA and OWAS have been extensively applied in manufacturing (e.g., roof stick bending) [15] and agriculture (e.g., essential oil extraction using motion capture for posture analysis) [16]. In construction (e.g., dumper operators and construction workers), these methods have also been widely used, yet most studies mainly highlight significant MSD risks without providing proactive workstation redesign or simulation-based solutions [17]. In contrast, welding and heavy equipment maintenance tasks have received less attention and the majority of existing research remains descriptive [18].

Moreover, although some recent studies have explored the integration of REBA or OWAS with digital human modeling, virtual reality or digital twin frameworks [19], [20], these approaches are still limited. Most ergonomic studies still rely heavily on observational methods without digital simulation support, which reduces their potential for predictive modeling and proactive design optimization [21], [22], [23].

To address these gaps, this study integrates REBA and OWAS observational tools with Virtual Human Modeling (VHM) using the 3D Static Strength Prediction Program (3DSSPP) to evaluate and improve welder postures through simulation. This integrated approach offers the advantage of identifying existing risks using traditional methods while also providing a predictive framework to design and validate ergonomic interventions prior to physical implementation, thereby reducing both cost and time. This research contributes to ergonomic intervention methodologies by:

1. combining traditional and digital ergonomic assessment methods for comprehensive posture evaluation,
2. simulating spinal load distribution and evaluating design iterations before physical implementation,
3. proposing evidence-based workstation improvements tailored to welding tasks in heavy-duty settings.

Compared to studies that rely solely on observational approaches, the integrated use of REBA, OWAS, VHM and 3DSSPP minimizes observer bias, provides quantitative biomechanical validation and enables proactive workstation redesign before implementation.

## 2. Material and method

This study employs a quantitative descriptive research design, focusing on ergonomic risk assessment and intervention in industrial work environments involving manual labor tasks. The research integrates direct observational analysis, ergonomic risk evaluation and digital human modeling to identify and mitigate MSDs risks.

### 2.1. Research design and data collection

The study is structured into three main phases: initial survey, posture assessment and simulation-based ergonomic redesign. Data were collected through questionnaires, direct observations, anthropometric measurements and posture simulation software. An initial survey using the Nordic Body Map (NBM) was conducted to identify the primary sources of musculoskeletal discomfort among workers, guiding the focus of the subsequent posture assessment. Seven participants from different job categories (welding and lathing) were assessed before and after work shifts. Although only one welder recorded a substantially higher NBM score compared to other respondents, this case was selected as a critical case study. The welder's task involved repetitive and physically demanding postures, which consistently generated musculoskeletal complaints in multiple body regions. This marked difference in discomfort levels relative to other operators provided strong justification for concentrating on welding as the most ergonomically problematic task within the workshop. A critical case approach ensures that interventions designed for the highest-risk posture also provide transferable insights for less extreme conditions.

Direct observations and interviews were conducted to record key posture-related factors, including angles of the neck, trunk, legs, upper arms, forearms and wrists, load and grip factors and movement frequency. These variables were then analyzed using Rapid Entire Body Assessment (REBA) and Ovako Working Analysis System (OWAS). REBA evaluates body posture risks without requiring highly precise angle measurements. The method involves scoring two groups (Group A: neck, trunk, legs; Group B: upper limbs) and combining them into a composite risk score. This enables the identification of high-risk postures requiring intervention [24]. OWAS classifies posture risks based on back, arm, and leg positions, including load handling, and provides risk categories based on frequency and severity [25], [26].

Anthropometric measurements were used to support ergonomic redesigns. Key body dimensions (popliteal height, hip width, buttock-popliteal length, sitting and standing elbow height) were collected using both primary measurements and Indonesian anthropometric references. These data were essential for designing posture-corrective equipment tailored to workers' physical characteristics.

### 2.2. Research design and data collection

To simulate and evaluate the ergonomic impact of design modifications, the 3D Static Strength Prediction Program (3DSSPP) developed by the University of Michigan was utilized [27], [28]. By integrating REBA, OWAS, anthropometry, and virtual human modeling, this study provides a comprehensive method for ergonomic assessment and design optimization. The findings provide a foundation for implementing

ergonomic interventions to reduce the risk of MSDs in heavy-duty industrial tasks.

### 3. Results and discussions

This study investigates two welding postures commonly adopted in heavy-duty repair tasks: a sitting-squatting position (Posture 1) and a standing position (Posture 2). Each posture presents different ergonomic risks depending on the nature of the welding tasks and workspace constraints. The analysis aims to determine which posture poses a greater risk of MSDs and to propose ergonomic improvements based on the assessment results.

#### 3.1. Initial musculoskeletal discomfort assessment

To identify the primary source of musculoskeletal discomfort, a preliminary Nordic Body Map (NBM) survey was conducted before and after work shifts [29]. The NBM survey results are summarized in Table 1. Respondent 1 (a welder) scored significantly higher than others, indicating substantial discomfort across multiple body regions. In contrast, other respondents working in lathing reported significantly lower scores. These findings highlight welding as the most ergonomically problematic task in the workshop, reinforcing the need for posture-specific ergonomic analysis. Subsequent sections therefore focus on welding postures to evaluate ergonomic risks and develop targeted interventions.

#### 3.2. Ergonomic assessment of Posture 1

Posture 1 is characterized by a sitting-squatting position used during precision welding tasks as shown in Fig. 1. Observations were conducted for one hour. The REBA assessment evaluated ergonomic factors, including body angles, load handling, grip conditions and muscle activity. The assessment factors and corresponding scores are presented in Table 2.

The REBA assessment for Posture 1 yielded a Group A score of 9, derived from significant trunk flexion (30°), neck bending (31°) and an asymmetric leg position. This score increased to 10 after accounting for a 5 kg load. Group B scored 7 based on elevated upper arm and wrist angles and increased to 8 after considering coupling conditions. The combined C score was 12 and with an additional point for static muscle activity, leading to a final score of 13. The result was further validated using ErgoFellow 3.0 software in order to ensure the accuracy of the manual assessment [30], [31], which confirmed the same score. According to the REBA classification table, this score falls within the >11 range, indicating a risk level of 4, classified as very high risk [32]. The high REBA score observed in Posture 1 is consistent with previous findings in manual concrete block production, where squatting and bending postures also yielded a REBA score of 11, classified as very high risk [33]. Workers reported musculoskeletal complaints in the back, arms, wrists, calves and thighs due to prolonged static loading in similar postures.

**Table 1**  
The results of the NBM survey.

Subject	Age	Task	Total score	Category
Respondent 1	31	Welding	45	High
Respondent 2	22	Lathing	7	Low
Respondent 3	24	Lathing	11	Low
Respondent 4	35	Lathing	18	Low
Respondent 5	22	Lathing	9	Low
Respondent 6	20	Lathing	18	Low
Respondent 7	30	Lathing	13	Low



Fig. 1. Posture 1 from: (a) right, (b) rear, and (c) left views.

**Table 2**  
Factors assessed by REBA for Posture 1.

No.	Factors	Identification
1	Neck	Forming an angle of 56° and bending 31°
2	Trunk	Forming an angle of 30° and bending 8°
3	Legs	Forming an angle of 132° with one leg supporting the trunk
4	Load	5 kilograms or 11 lbs
5	Upper arm	Forming an angle of 69° and moving away from the trunk at an angle of 43°
6	Forearm	Forming an angle of 102°
7	Wrist	Forming an angle of 58° and the palm is turned inward
8	Coupling	The rubber on the handle is peeling off
9	Activity	Welding in a static state

**Table 3**  
Factors assessed in OWAS for posture 1.

No.	Factors	Identification
1	Back	Forming an angle of 30°
2	Arms	Both arms are under the shoulders
3	Legs	Both legs bent in a squatting position
4	Load	5 kilograms or 11 lbs



(a)



(b)



(c)

**Fig. 2.** Posture 2 (standing) from: (a) right, (b) rear, and (c) left views.

**Table 4**  
Factors assessed by REBA for Posture 2.

No.	Factors	Identification
1	Neck	Forming an angle of 30° and bending 30°
2	Trunk	Forming an angle of 4° and bending 9°
3	Legs	Both legs support the trunk
4	Load	5 kilograms or 11 lbs
5	Upper arm	Forming an angle of 11°
6	Forearm	Forming an angle of 96°
7	Wrist	Forming an angle of 18° and the palm is turned inward
8	Coupling	The rubber on the handle is peeling off
9	Activity	Welding in a static state

**Table 5**  
Factors assessed in OWAS for posture 2.

No.	Factors	Identification
1	Back	In the straight position
2	Arms	Both arms are under the shoulders
3	Legs	Standing on both feet
4	Load	5 kilograms or 11 lbs

**Table 6**  
Indonesian anthropometric data [39].

No.	Dimensions	5 <sup>th</sup>	50 <sup>th</sup>	95 <sup>th</sup>
1	Popliteal height	38	43	49
2	Hip width	28	35	43
3	Buttocks popliteal	31	40	48
4	Sitting elbow height	24	32	40
5	Standing elbow height	98	105	113

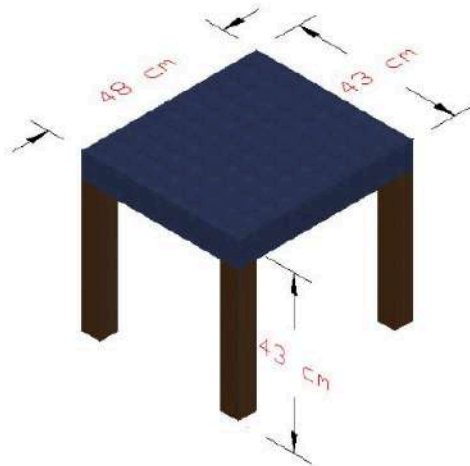

**Fig. 3.** Workbench design.

These parallels reinforce that sustained squatting-bending positions impose considerable ergonomic risks across different manual industries, validating the present assessment results. Following the REBA assessment, the OWAS method was performed to further classify postural strain. The identified OWAS assessment factors for Posture 1 are summarized in Table 3.

The OWAS analysis validated using ErgoFellow 3.0, produced a posture code of 2-1-5-1, corresponding to a risk level of 3 (moderate risk). According to the OWAS assessment table, back and leg positions were classified as high risk (scores of 3 and 4, respectively), while the arms were classified as low risk (score of 1) [32]. These results highlight that while REBA identified very high overall risk, OWAS emphasized localized high-risk areas, particularly in the lower limbs and spine. The alignment of both methods underscores the urgent need for targeted interventions, including posture adjustments and workstation redesign to mitigate long-term MSD risks.

### 3.3. Ergonomic assessment of Posture 2

Posture 2 corresponds to a standing position commonly adopted during welding tasks (

Fig. 2). This posture involves prolonged standing combined with repetitive upper-body movements, potentially leading to musculoskeletal strain. The REBA assessment for Posture 2 was conducted to evaluate

ergonomic risk factors, including body angles, load handling, grip conditions and muscle activity (Table 4).

The assessment process assigned an initial score of 6 to Group A, which evaluates the neck, trunk and legs, and a score of 3 to Group B, which focuses on the upper arm, forearm and wrist. The final C score was recorded as 6, leading to a Final REBA Score of 7. This score indicates a moderate ergonomic risk (risk level 2), suggesting that while Posture 2 does not pose an immediate danger, prolonged exposure without corrective interventions could contribute to musculoskeletal discomfort. To further evaluate postural strain in Posture 2, the OWAS was performed. The assessment focused on key ergonomic factors, including back, arm, and leg positions, as well as the load handled by welders. The identified OWAS assessment factors are summarized in Table 5.

The manual OWAS analysis assigned a posture code of 1-1-2-1, corresponding to risk level 1, which is classified as low-risk. According to the OWAS classification, risk scores by body region were back = 1 (low), arms = 1 (low) and legs = 2 (moderate) [32]. The ErgoFellow 3.0 validation confirmed identical results. This classification indicates a normal posture with no significant impact on the musculoskeletal system. The relatively low risk for Posture 2 is attributed to neutral spine alignment, balanced bilateral foot support and minimal trunk flexion, all of which reduce lumbar compression forces.

A comparison with previous literature provides additional context for interpreting the ergonomic risk classification of Posture 2 in the present study. As reported in [34], novice welders in a Malaysian technical institution exhibited an average REBA score of 9, classified as a high-risk category, primarily due to trunk flexion, neck bonding and varied lower limb positions observed during standing welding tasks.

In contrast, the standing posture assessed as Posture 2 in this study recorded a REBA score of 7, classified as moderate risk. The lower score is supported by the quantitative measurements presented in Table 4, which show minimal trunk flexion with slight bending, balanced bilateral foot support and moderate neck flexion. Upper limb angles and a light load of 5 kg further reduced physical demand. These favourable ergonomic factors collectively minimized lumbar compression forces and musculoskeletal strain, explaining the moderate risk classification compared to the higher-risk standing welding postures reported in [34].

Results from related research further indicate that even moderate-risk postures can contribute to musculoskeletal strain, when tasks are prolonged and repetitive [35]. Welders in that study exhibit high prevalence rates of lower back, shoulder and wrist pain, with significant associations between elevated REBA scores and self-reported discomfort. Additional risk factors such as long working hours and lack of physical activity exacerbated these outcomes, while protective factors included work-rest breaks and higher job satisfaction. This evidence suggests that although

Posture 2 demonstrates a reduced risk profile compared to previously reported standing welding postures, preventive ergonomic strategies remain essential to mitigate the long-term progression of work-related MSDs [36].

#### 3.4. Ergonomic intervention and design evaluation

To mitigate the identified risks, a series of ergonomic interventions and design modifications was proposed and evaluated. For Posture 1, the primary target areas for posture improvement include the neck, trunk, forearms, wrists, and feet. The primary objective is to shift from a sitting-squatting to a proper sitting posture, which has been shown to reduce leg strain, minimize energy expenditure and improve blood circulation. Research suggests that working in a sitting position is preferable for tasks requiring precision and prolonged durations [37]. The seat design must allow variations in posture to accommodate movement flexibility [38].

A customized workbench was designed using Indonesian anthropometric data (Table 6) [39], ensuring comfort, safety, and ergonomic practicality for prolonged use (2–6 hours per component) (Fig. 3). The bench height is determined based on the popliteal height of P50, while width and length are designed based on shoulder width and buttocks-popliteal distance using the large percentile (P95).

A proper worktable is also necessary to compensate for height variations when working in a sitting position. Sitting elbow height and popliteal height were used as references to design an optimal table height, tested through three percentile-based experimental heights: small percentile (62 cm), middle percentile (75 cm), and large percentile (89 cm).

The 3D Static Strength Prediction Program (3DSSPP) human model simulation confirmed that a table height of 75 cm provides the most natural body positioning, as seen in Fig. 4. The final worktable dimensions are 100 cm in length and 50 cm in width, constructed from metal or steel to withstand heavy loads (Fig. 5).

After implementation, the redesigned workstation successfully reduced the REBA score to 6 (moderate risk, level 2) and the OWAS code to 1-1-1-1 (low risk, level 1). The 3DSSPP analysis validated this improvement, indicating an L4/L5 spinal load of 1789 N, which falls within the safe category. The design optimization of an excavator driver cabin in [40], which included adjustments based on anthropometric data, resulted in a reduction of REBA scores, supporting the effectiveness of this intervention.

For Posture 2, improvements focused on adjusting the height of the small lathe, a primary workspace for standing welders. Using the standing elbow height from the middle percentile (P50) of 105 cm, the small lathe was raised by 5 cm from its previous height of 100 cm. The new height of 105 cm better aligns with ergonomic requirements. The human model simulation confirmed improved posture ergonomics (Fig. 6).

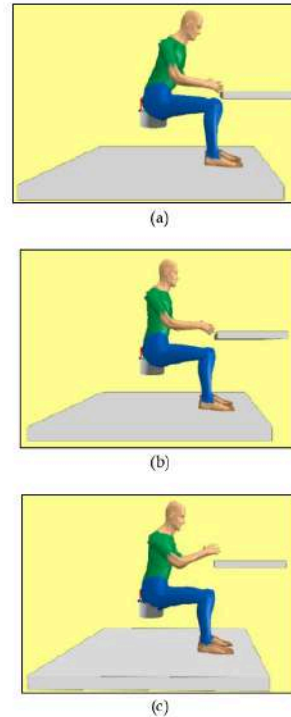

Fig. 4. Worktable height simulation: (a) 62, (b) 75 and (c) 89 cm.

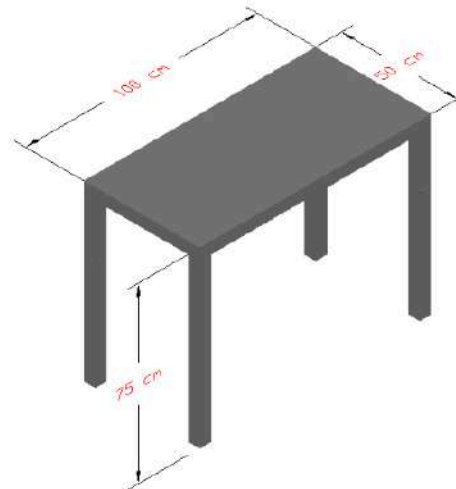

Fig. 5. Workbench design.

This adjustment resulted in a reduced REBA score of 5 (moderate risk, level 2) and the OWAS code to 1-1-2-1 (low risk, level 1). The 3DSSPP analysis validated this improvement, indicating an L4/L5 spinal load of 1100 N (112 kg), which falls within the safe category.

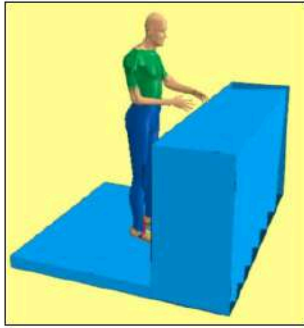

Fig. 6. Posture 2 improvement simulation.

**Table 7**  
Anthropometric data for welders.

Anthropometric data	Dimensions (cm)
Popliteal Height	47
Hip Width	52
Buttocks-popliteal	51
Sitting Elbow Height	28
Standing Elbow Height	105



Fig. 7. Adjustable workbench for welders: (a) isometric view and (b) front view.

In addition to Indonesian anthropometric data, actual measurements of the welders were collected for better customization (Table 7). Compared to standard

Indonesian anthropometry, welders exhibited larger dimensions, particularly in popliteal height, hip width, and buttocks-popliteal distance (4 cm larger than standard data). These deviations have direct implications for workbench ergonomics, as a fixed-height bench would not accommodate the full range of body sizes, potentially increasing awkward postures and localized muscle strain. To address this, a hydraulic-adjustable bench with a height range of 38-49 cm was proposed (Fig. 7). This configuration allows each user to adjust the bench height relative to their own popliteal and elbow height, thereby maintaining optimal elbow-table angles and reducing trunk flexion.

The hydraulic mechanism enables smooth and precise vertical movement by applying fluid pressure, allowing operators to finely set the seat height with minimal effort and high accuracy, without interrupting workflow. Hydraulics systems are widely recognized for their precision and control, which are critical in adjustable benches and ergonomic seats [41]. Hydraulics were selected over mechanical systems because they provide stable positioning, durability under heavy industrial use and ease of fine-tuning, making them more reliable in demanding environments [42]. These qualities ensure that welders can quickly adapt the bench to their body dimensions and working posture, improving both comfort and safety [43].

Studies on user-furniture interaction found that ergonomic features such as adjustable seat height significantly enhance comfort and reduce muscle strain when customized to an individual's anthropometric profile [44]. Specifically, adjustable seat height reduced thigh pressure by 8.5% over prolonged periods, while maintaining postural stability and long-term usability through dynamic positioning. Adjustable designs also support dynamic postures, which are more effective in sustaining comfort and reducing fatigue than static positions. Previous ergonomic design studies in office settings also emphasize that adjustable features are critical for enhancing user comfort and reducing strain when tailored to anthropometric data [45]. These findings reinforce the universal importance of adjustability and support the adoption of a hydraulic-adjustable design for welding workstations where tasks last several hours.

### 3.5. Preventing MSDs injuries

The primary strategy for preventing MSDs is the implementation of the redesigned workbench and seating system. This workstation was specifically developed to minimize awkward postures, reduce static loads and accommodate a wider range of worker anthropometry. To ensure maximum effectiveness, the redesigned table is integrated with a structured standard operating procedure (SOP) that combines engineering controls with participatory ergonomics [46], [47], behavioural safety [48] and continuous monitoring [49]. The proposed SOP is described as follows:

1. Early symptom reporting: workers are encouraged to report any discomfort promptly. The redesigned workbench, which incorporates adjustable height and seating support, makes it easier to identify whether improper adjustment contributes to symptoms [50]. Coupled with structured safety training and a positive reporting culture [51], early detection helps prevent minor discomfort from developing into chronic MSDs.
2. Supervisor inspection and anthropometric adjustment: supervisors are responsible for ensuring that the workbench height, seating angle and footrest are adjusted to match each worker's anthropometry. Since the redesigned workstation is adjustable, proactive fitting reduces exposure to risk factors and has been shown to lower injury rates [52], [53].
3. Corrective measures: when symptoms or postural deviations are detected, corrective actions such as posture guidance and workstation reconfiguration are implemented [54]. The redesigned table allows quick modification of surface height and tool placement, reducing forward bending and shoulder elevation, two key contributors to MSDs.
4. Monitoring the progression of symptoms: digital tools and standardized instruments are employed to track worker conditions [55]. The redesigned workbench layout provides sufficient clearance and sensor-mounting options [56], supporting continuous monitoring of posture and workload.
5. Medical examinations: when symptoms persist despite workstation adjustments, a medical assessment is conducted [51]. Data from the adjustable workstation settings assist in identifying whether specific postures or loads are linked to worker discomfort, enabling more targeted clinical interventions.
6. Documentation and continuous improvement: in which diagnosis records are systematically utilized to refine workstation design, update training modules and sustain a feedback loop for long-term prevention [57].

### 3.6. Managerial implications and future research

This study offers clear managerial implications for heavy industrial settings. The integrated use of traditional ergonomic tools with digital human modeling provides a robust methodology for identifying and proactively addressing occupational risks. The significant reduction in MSDs risk for the sitting-squatting posture, as validated by both observational and simulation methods, provides a strong, quantifiable business case for investing in ergonomic workstations. This approach shifts safety from a reactive measure to a proactive strategy that can enhance worker well-being, increase productivity, and potentially reduce compensation costs.

From an economic perspective, investment in ergonomic workstations can yield long-term savings by reducing the incidence of MSD-related injuries, thereby

lowering compensation claims, absenteeism and medical expenses. At the same time, improved comfort and safety are expected to enhance productivity and work quality, making such interventions a cost-effective strategy for industrial settings.

The validity of the simulation is supported by the well-established reliability of the 3DSSPP, developed by the University of Michigan [58]. 3DSSPP has been extensively applied in industrial ergonomics research and validated against empirical biomechanical data, particularly for predicting spinal loads, joint moments and postural stresses. Its ability to replicate realistic human postures and estimate physiological responses provides a strong justification for its use as a valid tool to support the redesign of welding workstations in this study.

A key limitation of this study is its small sample size, especially for the initial NBM survey and anthropometric data collection. Future research should expand the study to a larger population and other industrial sectors to validate the generalizability of these findings. It would also be valuable to conduct a longitudinal study to measure the long-term impact of these ergonomic interventions on worker health and productivity. Beyond these methodological extensions, future studies may also explore advanced technological integrations such as wearable posture sensors and digital monitoring systems, which would enable real-time risk detection, proactive intervention and further optimization of ergonomic practices in dynamic industrial settings.

## 4. Conclusions

This study examined the persistent ergonomic risks associated with welding activities, where specific postures were identified as contributing significantly to musculoskeletal discomfort. By applying both observational and digital simulation methods, the research identified the source of ergonomic strain and proposed evidence-based solutions. The redesign of the workstation demonstrated the value of anthropometry-driven modifications, enabling safer postures through an adjustable workbench and improved seating. For standing tasks, height adjustments of equipment offered measurable improvements in postural safety, showing that relatively simple engineering controls can yield meaningful ergonomic benefits. Beyond technical modifications, this study emphasized the integration of ergonomic interventions within a structured prevention framework. The proposed SOP, covering early symptom reporting, supervisor-led workstation adjustments, corrective actions, systematic monitoring, medical referral and continuous documentation, ensures that risk reduction is sustained through organizational practices.

From a managerial perspective, these findings demonstrate that proactive ergonomic investment reduces MSDs, enhances worker health and lowers costs related to injury claims.

Future research should validate these results with larger-scale data while exploring the integration of wearable posture sensors and digital monitoring for early detection and prevention.

#### CRedit author statement

**Sanfransyul Arung Tasik:** Data Curation, Formal Analysis, Writing – Original Draft. **Rahmi Maulidya:** Conceptualization, Methodology, Supervision, Validation, Writing – Review & Editing. **Ika Wahyu Utami:** Conceptualization, Supervision, Validation, Writing – Review, Editing & Revision. **Dian Mardi Safitri,** **Novia Rahmawati:** Validation, Writing – Review & Editing. **Anik Nur Habyba:** Literature Review, Supporting Analysis, Writing – Review.

#### Acknowledgement

The authors would like to express their gratitude to the welding workshop staff for their cooperation during field data collection. Special appreciation is extended to Universitas Trisakti for providing academic and administrative support throughout this research. The constructive feedback from reviewers also contributed significantly to improving the quality of this manuscript.

#### Disclosure statement

The authors declare no conflicts of interest.

#### Funding statement

The study was conducted independently without external financial support.

#### Data availability statement

The authors confirm that the data supporting the findings of this study are available within the article or its supplementary materials.

#### AI usage statement

This manuscript utilizes generative AI and AI-assisted tools to improve readability and language. All AI-generated content has been reviewed and edited by the authors to ensure accuracy and scientific integrity. The authors take full responsibility for the content and conclusions of this work and disclose the use of AI to maintain transparency and comply with publisher guidelines.

#### References

- [1] M. Z. Muktar, S. B. Shamsudin, K. A. Lukman, and M. S. Jeffrey, "Assessment of Ergonomic Risk Levels and Working Performance of Pre-cast Construction Workers in Sabah," *Malaysian Journal of Public Health Medicine*, vol. 17, no. 2, pp. 151–158, 2017.
- [2] P. H. Jukka, T. Tan, and B. Kiat, "Global Estimates of Occupational Accidents and Work-Related Illnesses 2017," Workplace Safety and Health Institute, Singapore, Sep. 2017.
- [3] J. Park, Y. Kim, and B. Han, "Work Sectors with High Risk for Work-Related Musculoskeletal Disorders in Korean Men and Women," *Safety and Health at Work*, vol. 9, no. 1, pp. 75–78, Mar. 2018, doi: 10.1016/j.shaw.2017.06.005.
- [4] M. F. Antwi-Afari, H. Li, D. J. Edwards, E. A. Pärn, J. Seo, and A. Y. L. Wong, "Biomechanical Analysis of Risk Factors for Work-Related Musculoskeletal Disorders during Repetitive Lifting Task in Construction Workers," *Automation in Construction*, vol. 83, pp. 41–47, Nov. 2017, doi: 10.1016/j.autcon.2017.07.007.
- [5] M. S. Rahman and J. Sakamoto, "The Risk Factors for the Prevalence of Work-Related Musculoskeletal Disorders among Construction Workers: A Review," *Research Expansion Alliance (REA)*, Jun. 01, 2024, doi: 10.22105/jarie.2023.413676.1561.
- [6] S. Kim, M. A. Nussbaum, and B. Jia, "Low Back Injury Risks during Construction with Prefabricated (Panelised) Walls: Effects of Task and Design Factors," *Ergonomics*, vol. 54, no. 1, pp. 60–71, Jan. 2011, doi: 10.1080/00140139.2010.535024.
- [7] S. Bulduk, E. Ö. Bulduk, and T. Süren, "Reduction of Work-Related Musculoskeletal Risk Factors Following Ergonomics Education of Sewing Machine Operators," *International Journal of Occupational Safety and Ergonomics*, vol. 23, no. 3, pp. 347–352, Jul. 2017, doi: 10.1080/10803548.2016.1262321.
- [8] K. Wong and A. H. S. Chan, "Emerging Issues in Occupational Safety and Health," *International Journal of Environmental Research and Public Health*, vol. 15, no. 12, p. 2897, Dec. 18, 2018, doi: 10.3390/ijerph15122897.
- [9] N. D. Nath, R. Akhavian, and A. H. Behzadan, "Ergonomic Analysis of Construction Worker's Body Postures Using Wearable Mobile Sensors," *Applied Ergonomics*, vol. 62, pp. 107–117, Jul. 2017, doi: 10.1016/j.apergo.2017.02.007.
- [10] D. Kee, "Systematic Comparison of OWAS, RULA, and REBA Based on a Literature Review," *International Journal of Environmental Research and Public Health*, vol. 19, no. 1, p. 595, Jan. 01, 2022, doi: 10.3390/ijerph19010595.
- [11] D. Kee, "Comparison of OWAS, RULA and REBA for Assessing Potential Work-Related Musculoskeletal Disorders," *International Journal of Industrial Ergonomics*, vol. 83, p. 103140, May 2021, doi: 10.1016/j.ergon.2021.103140.
- [12] M. Gómez-Galán, J. Pérez-Alonso, Á.-J. Callejón-Ferre, and J. López-Martínez, "Musculoskeletal Disorders: OWAS Review," *Industrial Health*, vol. 55, no. 4, pp. 314–337, 2017.
- [13] K. Enez and S. S. Nalbantoğlu, "Comparison of Ergonomic Risk Assessment Outputs from OWAS and REBA in Forestry Timber Harvesting," *International Journal of Industrial Ergonomics*, vol. 70, pp. 51–57, Mar. 2019, doi: 10.1016/j.ergon.2019.01.009.
- [14] M. Hita-Gutiérrez, M. Gómez-Galán, M. Díaz-Pérez, and Á. J. Callejón-Ferre, "An Overview of REBA Method

- Applications in the World," *International Journal of Environmental Research and Public Health*, vol. 17, no. 8, p. 2635, Apr. 02, 2020, doi: 10.3390/ijerph17082635.
- [15] M. Joshi, V. Deshpande, and H. Shukla, "The Investigation of Ergonomic and Energy Intervention in Roof Sticks Bending Facility," *International Journal of Mechanical and Production Engineering Research and Development*, vol. 9, no. Special Issue, pp. 220–225, 2019.
- [16] G. G. Reyes-Zárate, "A Digital REBA System Based on Kinect and Its Benefits for Ergonomic Assessment," in *Smart Innovation, Systems and Technologies*, 2024, pp. 3–11, doi: 10.1007/978-981-99-7210-4\_1.
- [17] B. M. Kunar, M. Aruna, and M. B. Kar, "Postural Analysis of Dumper Operators and Construction Workers – A Case Study," *Journal of Mines, Metals and Fuels*, vol. 69, no. 6, pp. 180–185, 2021, doi: 10.18311/jmmf/2021/28525.
- [18] F. Colombo, "Ergonomia e Organizzazione del Lavoro," *Rivista Italiana della Saldatura*, vol. 58, no. 6, pp. 817–822, 2006.
- [19] M. Caterino, M. Rinaldi, and M. Fera, "Digital Ergonomics: An Evaluation Framework for the Ergonomic Risk Assessment of Heterogeneous Workers," *International Journal of Computer Integrated Manufacturing*, vol. 36, no. 2, pp. 239–259, 2023, doi: 10.1080/0951192X.2022.2090023.
- [20] J. Zhong, V. Weistroffer, P. Maurice, C. Andriot, and F. Colas, "Interacting with a Torque-Controlled Virtual Human in Virtual Reality for Ergonomics Studies," in *Proceedings – 2022 IEEE Conference on Virtual Reality and 3D User Interfaces Abstracts and Workshops, VRW 2022*, 2022, pp. 678–679, doi: 10.1109/VRW55335.2022.00190.
- [21] J. Seo, K. Yin, and S. Lee, "Automated Postural Ergonomic Assessment Using a Computer Vision-Based Posture Classification," in *Construction Research Congress 2016: Old and New Construction Technologies Converge in Historic San Juan - Proceedings of the 2016 Construction Research Congress, CRC 2016*, 2016, pp. 809–818, doi: 10.1061/9780784479827.082.
- [22] L. Dulina, M. Kramárov, M. Krajčovič, and D. Plinta, "Ergonomic Analysis and the Tracking Systems," in *Ergonomics For People With Disabilities: Design For Accessibility*, 2018, pp. 135–144, doi: 10.2478/9783110617832-011.
- [23] A. Golabchi, S. Han, A. R. Fayek, and S. Abourizk, "Stochastic Modeling for Assessment of Human Perception and Motion Sensing Errors in Ergonomic Analysis," *Journal of Computing in Civil Engineering*, vol. 31, no. 4, 2017, doi: 10.1061/(ASCE)CP.1943-5487.0000655.
- [24] S. Hignett and L. McAtamney, "Rapid Entire Body Assessment (REBA)," *Applied Ergonomics*, vol. 31, no. 2, pp. 201–205, Apr. 2000, doi: 10.1016/S0003-6870(99)00039-3.
- [25] B. Gajšek, A. Draghici, M. E. Boatca, A. Gaureanu, and D. Robescu, "Linking the Use of Ergonomics Methods to Workplace Social Sustainability: The Ovako Working Posture Assessment System and Rapid Entire Body Assessment Method," *Sustainability (Switzerland)*, vol. 14, no. 7, Apr. 2022, doi: 10.3390/su14074301.
- [26] O. Karhu, P. Kansil, and I. Kuorinka, "Correcting Working Postures in Industry: A Practical Method for Analysis," *Applied Ergonomics*, vol. 8, no. 4, pp. 199–201, Dec. 1977.
- [27] N. Sarter, "3DSSPP: Background Information." 2020. [Online]. Available: <https://c4e.engin.umich.edu/tools-services/3dsspp-software/3dsspp-background-information/>
- [28] A. D. Hall, N. J. La Delfa, C. Loma, and J. R. Potvin, "A Comparison Between Measured Female Linear Arm Strengths and Estimates from the 3D Static Strength Prediction Program (3DSSPP)," *Applied Ergonomics*, vol. 94, p. 103415, Jul. 2021, doi: 10.1016/j.apergo.2021.103415.
- [29] D. M. Safitri, N. C. Rizani, and F. Alexander, "Perancangan Fasilitas Kerja yang Ergonomis Stasiun Perakitan di PT X untuk Mengurangi Risiko Work-Related Musculoskeletal Disorders," *J@TI Undip*, vol. 3, no. 3, pp. 184–190, 2008.
- [30] FBFSistemas, "ErgoFellow 3.0," [Online]. Available: <https://www.fbfsistemas.com/ergonomics.html>
- [31] C. P. Dewangan and A. K. Singh, "Ergonomic Study and Design of the Pulpit of a Wire Rod Mill at an Integrated Steel Plant," *Journal of Industrial Engineering*, vol. 2015, pp. 1–11, Feb. 2015, doi: 10.1155/2015/412921.
- [32] Tarwaka, *Ergonomi Industri Dasar-Dasar Pengetahuan Ergonomi dan Aplikasi di Tempat Kerja: Penilaian Risiko Gangguan Sistem Muskuloskeletal*, 2nd ed. Surakarta: Harapan Press, 2019.
- [33] L. Widodo, S. Ariyanti, and A. Jason, "Ergonomic Intervention to Improve the Productivity of Brick Press Tool in Small and Medium Enterprise (SME) Akheng Kobar," in *IOP Conference Series: Materials Science and Engineering*, vol. 847, no. 1, May 2020, p. 012057, doi: 10.1088/1757-899X/847/1/012057.
- [34] K. F. Bin Salleh, S. M. Fadzil, and M. Y. M. Daud, "Ergonomic Posture Assessment Approaches for New Welder: A Study in Technical Institution," *Jurnal Kejuruteraan*, vol. 35, no. 5, pp. 1045–1054, Sep. 2023, doi: 10.17576/jkukm-2023-35(5)-06.
- [35] C. Elvis, N. France, and E. Patience, "Risk Factors for Work-Related Musculoskeletal Disorders among Welders in the Informal Sector under Resource Constrained Settings," *Work*, vol. 72, no. 1, pp. 239–252, 2022, doi: 10.3233/WOR-205275.
- [36] A. J. Van Der Beek, J. T. Dennerlein, M. A. Huysmans, S. E. Mathiassen, A. Burdorf, W. van Mechelen, J. H. van Dieën, M. H. W. Frings-Dresen, E. A. Holtermann, K. Janwantanakul, A. van der Molen, D. Rempel, L. Straker, K. Walker-Bone, and P. Coenen, "A Research Framework for the Development and Implementation of Interventions Preventing Work-Related Musculoskeletal Disorders," *Scandinavian Journal of Work, Environment & Health*, vol. 43, no. 6, pp. 526–539, 2017, doi: 10.5271/sjweh.3671.
- [37] E. Grandjean, *Fitting the Task to the Man*, 4th ed. London: Taylor & Francis Inc, 1993.
- [38] S. Pheasant, *Body Space, Anthropometry, Ergonomics and Design*. London: Taylor & Francis Inc, 1998.
- [39] Antropometri Indonesia, "Rekap Data Antropometri Indonesia," [Online]. Available:

- [https://antropometriindonesia.org/index.php/detail/artikel/4/10/data\\_antropometri](https://antropometriindonesia.org/index.php/detail/artikel/4/10/data_antropometri)
- [40] K. Koushik Balaji and M. S. Alphin, "Computer-Aided Human Factors Analysis of the Industrial Vehicle Driver Cabin to Improve Occupational Health," *International Journal of Injury Control and Safety Promotion*, vol. 23, no. 3, pp. 240–248, 2016, doi: 10.1080/17457300.2014.992351.
- [41] P. Dudziński and A. Skurjat, "Impact of Hydraulic System Stiffness on Its Energy Losses and Its Efficiency in Positioning Mechanical Systems," *Energies*, vol. 15, no. 1, p. 294, 2022, doi: 10.3390/en15010294.
- [42] A. Vacca and G. Franzoni, *Hydraulic Fluid Power: Fundamentals, Applications, and Circuit Design*. 2021. [Online]. Available: <https://www.scopus.com/inward/record.uri?eid=2-s2.0-85126554373&partnerID=40&md5=87acde350bc3525e7d4dae5fc55d0498>
- [43] J. M. N. Silva, A. L. F. Correia, R. M. C. S. Almeida, and M. A. P. Vaz, "Evaluation of the Ergonomic Changes Made in the Presses Sector in a Metallurgical Industry," in *Occupational Safety and Hygiene - Proceedings of the International Symposium on Occupational Safety and Hygiene, SHO 2013*, 2013, pp. 347–350, doi: 10.1201/b14391-72.
- [44] M. Gao, "Analyze the Physical Interaction Between the User and the Furniture Design to Optimize Comfort and Functionality," *MCB Molecular and Cellular Biomechanics*, vol. 21, no. 2, 2024, doi: 10.62617/mcb457.
- [45] F. T. Basaria, M. K. Perdana, C. Harito, V. Puspita, R. Shafira, and S. A. Salsabilla, "Sustainable and Ergonomic Office Chair: ROSA Insights for Improved Workplace Health," in *IOP Conference Series: Earth and Environmental Science*, vol. 1488, no. 1, 2025, p. 012056, doi: 10.1088/1755-1315/1488/1/012056.
- [46] A. Choobineh, M. Motamedzade, M. Kazemi, A. Moghimbeigi, A. H. Pahlavian, and M. R. Azmoon, "A Multilayered Ergonomic Intervention Program on Reducing Musculoskeletal Disorders in an Industrial Complex—A Dynamic Participatory Approach," *International Journal of Industrial Ergonomics*, vol. 86, p. 103221, 2021, doi: 10.1016/j.ergon.2021.103221.
- [47] E. M. Capodaglio, "Participatory Ergonomics for the Reduction of Musculoskeletal Exposure of Maintenance Workers," *International Journal of Occupational Safety and Ergonomics*, vol. 28, no. 1, pp. 376–386, 2022, doi: 10.1080/10803548.2020.1761670.
- [48] R. W. Bunch, "An Integrated Ergo-Behavioral Approach to Prevention of Musculoskeletal Disorders (MSDs)," in *ASSE Professional Development Conference and Exposition 2004*, 2004. [Online]. Available: <https://www.scopus.com/inward/record.uri?eid=2-s2.0-85058445175&partnerID=40&md5=d7d2b309c082b5ac413c04f0b454044>
- [49] J. O. Adibeli, Y.-K. Liu, N. J. Awodi, A. K. Chepkwony, and A. Ayodeji, "Ergonomic Analysis in Nuclear Decommissioning: A Comprehensive Path Planning Strategy for Workers Well-Being," *Nuclear Engineering and Design*, vol. 426, p. 113409, 2024, doi: 10.1016/j.nucengdes.2024.113409.
- [50] C. O. Soares, B. F. Pereira, M. V. P. Gomes, L. P. Marcondes, F. C. Gomes, and J. S. De Melo-Neto, "Preventive Factors Against Work-Related Musculoskeletal Disorders: Narrative Review," *Revista Brasileira de Medicina do Trabalho*, vol. 17, no. 3, pp. 415–430, 2019, doi: 10.5327/Z1679443520190360.
- [51] M. Kyung, S.-J. Lee, L. M. Wagner, C. Harris-Adamson, and O. Hong, "Factors Associated With Reporting Attitudes of Work-Related Musculoskeletal Disorders Among Direct Care Workers in South Korea," *Workplace Health & Safety*, vol. 72, no. 8, pp. 345–353, 2024, doi: 10.1177/21650799241247078.
- [52] W. S. Shaw, M. M. Robertson, R. K. McLellan, S. Verma, and G. Pransky, "A Controlled Case Study of Supervisor Training to Optimize Response to Injury in the Food Processing Industry," *Work*, vol. 26, no. 2, pp. 107–114, 2006. [Online]. Available: <https://www.scopus.com/inward/record.uri?eid=2-s2.0-33645305458&partnerID=40&md5=179e3822c9d5ee24d4fc640b8b3e317b>
- [53] D. C. Cole, S. Hogg-Johnson, M. Manno, S. Ibrahim, R. P. Wells, and S. E. Ferrier, "Reducing Musculoskeletal Burden Through Ergonomic Program Implementation in a Large Newspaper," *International Archives of Occupational and Environmental Health*, vol. 80, no. 2, pp. 98–108, 2006, doi: 10.1007/s00420-006-0107-6.
- [54] X. Jin, J. Wang, J. Liu, W. Li, L. Zhang, Y. Wang, and Y. Zhang, "Ergonomic Interventions to Improve Musculoskeletal Disorders Among Vehicle Assembly Workers: A One-Year Longitudinal Study," *BMC Public Health*, vol. 25, no. 1, p. 21798, 2025, doi: 10.1186/s12889-025-21798-1.
- [55] C. Lanhers, B. Pereira, G. Garde, C. Maublant, F. Dutheil, and E. Coudeyre, "Evaluation of 'I-Preventive': A Digital Preventive Tool for Musculoskeletal Disorders in Computer Workers—A Pilot Cluster Randomised Trial," *BMJ Open*, vol. 6, no. 9, p. e011304, 2016, doi: 10.1136/BMJOPEN-2016-011304.
- [56] A. Greco, M. Caterino, M. Fera, and S. Gerbino, "Digital Twin for Monitoring Ergonomics During Manufacturing Production," *Applied Sciences (Switzerland)*, vol. 10, no. 21, p. 7758, 2020, doi: 10.3390/app10217758.
- [57] J. Oakman and W. Macdonald, "The APHIRM Toolkit: An Evidence-Based System for Workplace MSD Risk Management," *BMC Musculoskeletal Disorders*, vol. 20, no. 1, p. 504, 2019, doi: 10.1186/s12891-019-2828-1.
- [58] N. Sarter, "3DSSPP: Background Information," [Online]. Available: [https://c4e.engin.umich.edu/tools-services/3dsspp-software/3dsspp-background-information/?utm\\_source=chatgpt.com](https://c4e.engin.umich.edu/tools-services/3dsspp-software/3dsspp-background-information/?utm_source=chatgpt.com)

#### Author information



**Sanfransyul Arung Tasik** received his bachelor's degree in Industrial Engineering from Universitas Trisakti, Indonesia. His research interests include ergonomics and digital human modelling.



**Rahmi Maulidya** is a lecturer in the Department of Industrial Engineering, Universitas Trisakti, Indonesia. She earned her doctoral degree in Industrial Engineering from Institut Teknologi Bandung, Indonesia. Her research interests include production scheduling, supply chain management, lean manufacturing and sustainable product-service systems.



**Ika Wahyu Utami** is a Junior Lecturer in the Department of Industrial Engineering, Universitas Trisakti, Indonesia. She received her master's degree in Earth Sciences from National Central University, Taiwan. Her research interests include geophysics, environmental studies, ergonomics and IoT-based instrumentation.



**Dian Mardi Safitri** is a researcher in industrial ergonomics and safety, associated with the Center of Excellence for Ergonomics, Occupational Health and Safety at Universitas Trisakti. She completed her doctoral degree in Industrial Engineering from Universitas Indonesia, focusing on advancing knowledge and practices within her field of expertise.



**Novia Rahmawati** is a Lecturer in the Study Program of Industrial Management, College of Vocational Studies, IPB University, Indonesia. She received her master's degrees in industrial engineering from Institut Teknologi Bandung and from National Taiwan University of Science and Technology (NTUST), Taiwan. Her research interests include ergonomics, usability evaluation, human-computer interaction, and supply chain management.



**Anik Nur Habyba** is a lecturer in the Department of Industrial Engineering, Universitas Trisakti, Indonesia. Her research interests are in Kansei Engineering, Data Mining, Quality Engineering, Applied Statistics, and Industrial Management. She is currently a PhD student at the Department of Industrial Engineering and Management, Yuan Ze University, Taiwan. She can be reached at [anik@trisakti.ac.id](mailto:anik@trisakti.ac.id) and [s1148904@mail.yzu.edu.tw](mailto:s1148904@mail.yzu.edu.tw).

# TURNITIN TASIK ET.AL - 15 JUNI 2026

---

## ORIGINALITY REPORT

---

<b>10%</b>	<b>10%</b>	<b>5%</b>	<b>7%</b>
SIMILARITY INDEX	INTERNET SOURCES	PUBLICATIONS	STUDENT PAPERS

---

## MATCH ALL SOURCES (ONLY SELECTED SOURCE PRINTED)

---

7%

★ repository.maranatha.edu

Internet Source

---

Exclude quotes  On

Exclude bibliography  On

Exclude matches  < 10 words



Original research



## Integrating ergonomic intervention and digital human modelling for posture improvement in welding tasks

Sanfransyul Arung Tasik<sup>a</sup>, Rahmi Maulidya<sup>a</sup>, Ika Wahyu Utami<sup>a,\*</sup>, Dian Mardi Safitri<sup>a</sup>, Novia Rahmawati<sup>b</sup>, Anik Nur Habyba<sup>a,c</sup>

<sup>a</sup> Department of Industrial Engineering, Universitas Trisakti

<sup>b</sup> Study Program of Industrial Management, Collage of Vocational Studies, IPB University

<sup>c</sup> Department of Industrial Engineering and Management, Yuan Ze University, Taiwan

### ARTICLE INFO

#### Article history:

Received 19 September 2023

Received in revised form 4 December 2023

Accepted 6 December 2023

Published online 8 December 2023

#### Keywords:

MSDs

REBA

OWAS

Virtual Human Modeling

Posture Improvement

#### Editor:

Bobby Kurniawan

#### Publisher's note:

The publisher remains neutral concerning jurisdictional claims in published maps and institutional affiliations.

### ABSTRACT

Work-related musculoskeletal disorders (MSDs) are a persistent problem in welding, where awkward and prolonged postures elevate ergonomic risks. This study investigated two common welding postures in a heavy industrial workshop and aimed to design effective interventions by integrating traditional observational methods with digital human modeling. Ergonomic risks were first assessed using the Rapid Entire Body Assessment (REBA) and the Ovako Working Analysis System (OWAS). The REBA and OWAS analyses identified the sitting-squatting postures as very high risk, while the standing posture posed a moderate risk. Anthropometric data were applied in the 3D Static Strength Prediction Program (3DSSPP) to simulate and evaluate redesign options. The proposed adjustable workbench successfully reduced the sitting-squatting posture to a moderate risk category, whereas height modification of the small lathe provided only marginal improvements for standing posture. These findings confirm that combining observational analysis with digital simulation yields more reliable insights for ergonomic redesign. The results emphasize the need for proactive interventions to reduce MSD risks, improve worker comfort and enhance productivity in heavy industrial environments.

## 1. Introduction

With the growth of the industrial sector, concerns about occupational safety have intensified [1]. Among these concerns, work-related musculoskeletal disorders (MSDs) remain one of the most prevalent occupational health issues globally, especially in industrial sectors involving physically demanding tasks such as welding, machining and construction. The Workplace Safety and Health Institute (WSH) reports approximately 2.78 million annual deaths due to hazardous work conditions [2]. According to the International Labor Organization (ILO), MSDs rank second among occupational diseases, with 160 million cases recorded worldwide [3].

MSDs are particularly common in construction and heavy equipment maintenance industries, where workers are exposed to repetitive motion, awkward postures and high physical loads [4]-[7]. These ergonomic risk factors often result in long-term health

issues, reduced productivity and increased compensation costs [8], [9]. Therefore, improving workplace ergonomics through systematic and evidence-based strategies has become a critical concern for employers seeking to reduce risks and optimize conditions.

Body posture assessment methods such as the Rapid Entire Body Assessment (REBA) and the Ovako Working Analysis System (OWAS) have been widely used to identify ergonomic risks and guide interventions [10], [11]. These tools provide structured frameworks to evaluate limb angles, postural stress and movement frequency, offering practical solutions to reduce MSDs [12], [13]. However, the majority of REBA applications have been concentrated in manufacturing (24.18%) and agriculture (21.98%) [14], with limited implementation in heavy equipment repair industries.

For instance, REBA and OWAS have been extensively applied in manufacturing (e.g., roof stick bending) [15] and agriculture (e.g., essential oil

\*Corresponding author:

Email: [ika.wahyu@trisakti.ac.id](mailto:ika.wahyu@trisakti.ac.id)

<http://dx.doi.org/10.36055/jiss.v9i2.21977>

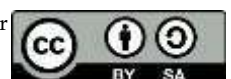

extraction using motion capture for posture analysis) [16]. In construction (e.g., dumper operators and construction workers), these methods have also been widely used, yet most studies mainly highlight significant MSD risks without providing proactive workstation redesign or simulation-based solutions [17]. In contrast, welding and heavy equipment maintenance tasks have received less attention and the majority of existing research remains descriptive [18].

Moreover, although some recent studies have explored the integration of REBA or OWAS with digital human modeling, virtual reality or digital twin frameworks [19], [20], these approaches are still limited. Most ergonomic studies still rely heavily on observational methods without digital simulation support, which reduces their potential for predictive modeling and proactive design optimization [21], [22], [23].

To address these gaps, this study integrates REBA and OWAS observational tools with Virtual Human Modeling (VHM) using the 3D Static Strength Prediction Program (3DSSPP) to evaluate and improve welder postures through simulation. This integrated approach offers the advantage of identifying existing risks using traditional methods while also providing a predictive framework to design and validate ergonomic interventions prior to physical implementation, thereby reducing both cost and time. This research contributes to ergonomic intervention methodologies by:

1. Combining traditional and digital ergonomic assessment methods for comprehensive posture evaluation,
2. Simulating spinal load distribution and evaluating design iterations before physical implementation,
3. Proposing evidence-based workstation improvements tailored to welding tasks in heavy-duty settings.

Compared to studies that rely solely on observational approaches, the integrated use of REBA, OWAS, VHM and 3DSSPP minimizes observer bias, provides quantitative biomechanical validation and enables proactive workstation redesign before implementation.

## 2. Material and method

This study employs a quantitative descriptive research design, focusing on ergonomic risk assessment and intervention in industrial work environments involving manual labor tasks. The research integrates direct observational analysis, ergonomic risk evaluation and digital human modeling to identify and mitigate MSDs risks.

### 2.1. Research design and data collection

The study is structured into three main phases: initial survey, posture assessment and simulation-based ergonomic redesign. Data were collected through questionnaires, direct observations, anthropometric measurements and posture simulation software. An

initial survey using the Nordic Body Map (NBM) was conducted to identify the primary sources of musculoskeletal discomfort among workers, guiding the focus of the subsequent posture assessment. Seven participants from different job categories (welding and lathing) were assessed before and after work shifts. Although only one welder recorded a substantially higher NBM score compared to other respondents, this case was selected as a critical case study. The welder's task involved repetitive and physically demanding postures, which consistently generated musculoskeletal complaints in multiple body regions. This marked difference in discomfort levels relative to other operators provided strong justification for concentrating on welding as the most ergonomically problematic task within the workshop. A critical case approach ensures that interventions designed for the highest-risk posture also provide transferable insights for less extreme conditions.

#### 2.1.1. Postural assessment data

Direct observations and interviews were conducted to record key posture-related factors, including angles of the neck, trunk, legs, upper arms, forearms and wrists, load and grip factors and movement frequency. These variables were then analyzed using:

- Rapid Entire Body Assessment (REBA): REBA evaluates body posture risks without requiring highly precise angle measurements. The method involves scoring two groups (Group A: neck, trunk, legs; Group B: upper limbs) and combining them into a composite risk score. This enables the identification of high-risk postures requiring intervention [24].
- Ovako Working Analysis System (OWAS): OWAS classifies posture risks based on back, arm, and leg positions, including load handling, and provides risk categories based on frequency and severity [25], [26].

#### 2.1.2. Anthropometric data

Anthropometric measurements were used to support ergonomic redesigns. Key body dimensions (popliteal height, hip width, buttock-popliteal length, sitting and standing elbow height) were collected using both primary measurements and Indonesian anthropometric references. These data were essential for designing posture-corrective equipment tailored to workers' physical characteristics.

### 2.2. Simulation and design evaluation

To simulate and evaluate the ergonomic impact of design modifications, the 3D Static Strength Prediction Program (3DSSPP) developed by the University of Michigan was utilized [27], [28]. The software allows:

1. Simulation of worker posture under varying workstation setups
2. Estimation of spinal loads and joint moments

3. Evaluation of whether force and posture fall within safe biomechanical limits

By integrating REBA, OWAS, anthropometry, and virtual human modeling, this study provides a comprehensive method for ergonomic assessment and design optimization. The findings provide a foundation for implementing ergonomic interventions to reduce the risk of MSDs in heavy-duty industrial tasks.

3. Results and discussions

This study investigates two welding postures commonly adopted in heavy-duty repair tasks: a sitting-squatting position (Posture 1) and a standing position (Posture 2). Each posture presents different ergonomic risks depending on the nature of the welding tasks and workspace constraints. The analysis aims to determine which posture poses a greater risk of MSDs and to propose ergonomic improvements based on the assessment results.

3.1. Initial musculoskeletal discomfort assessment

To identify the primary source of musculoskeletal discomfort, a preliminary Nordic Body Map (NBM) survey was conducted before and after work shifts [29]. The NBM survey results are summarized in Table 1.

Table 1. The results of the NBM survey.

Subject	Age	Job	Total Score	Category
Respondent 1	31	Welding	45	High
Respondent 2	22	Lathing	7	Low
Respondent 3	24	Lathing	11	Low
Respondent 4	35	Lathing	18	Low
Respondent 5	22	Lathing	9	Low
Respondent 6	20	Lathing	18	Low
Respondent 7	30	Lathing	13	Low

Respondent 1 (a welder) scored significantly higher than others, indicating substantial discomfort across multiple body regions. In contrast, other respondents working in lathing reported significantly lower scores. These findings highlight welding as the most ergonomically problematic task in the workshop, reinforcing the need for posture-specific ergonomic analysis. Subsequent sections therefore focus on welding postures to evaluate ergonomic risks and develop targeted interventions.

3.2. Ergonomic assessment of Posture 1

Posture 1 is characterized by a sitting-squatting position used during precision welding tasks (Figure 1). Observations were conducted for one hour. The REBA assessment evaluated ergonomic factors, including body angles, load handling, grip conditions and muscle activity. The assessment factors and corresponding scores are presented in Table 2.



(a)



(b)



(c)

Fig. 1. Posture 1 from right, rear and left views.

Table 2

Factors assessed by REBA for Posture 1.

No.	Factors	Identification
1	Neck	Forming an angle of 56° and bending 31°
2	Trunk	Forming an angle of 30° and bending 8°
3	Legs	Forming an angle of 132° with one leg supporting the trunk
4	Load	5 kilograms or 11 lbs
5	Upper arm	Forming an angle of 69° and moving away from the trunk at an angle of 43°
6	Forearm	Forming an angle of 102°
7	Wrist	Forming an angle of 58° and the palm is turned inward
8	Coupling	The rubber on the handle is peeling off
9	Activity	Welding in a static state

The REBA assessment for Posture 1 yielded a Group A score of 9, derived from significant trunk flexion (30°), neck bending (31°) and an asymmetric leg position. This score increased to 10 after accounting for a 5 kg load.

Group B scored 7 based on elevated upper arm and wrist angles and increased to 8 after considering coupling conditions. The combined C score was 12 and with an additional point for static muscle activity, leading to a final score of 13. The result was further validated using ErgoFellow 3.0 software in order to ensure the accuracy of the manual assessment [30], [31], which confirmed the same score. According to the REBA classification table, this score falls within the >11 range, indicating a risk level of 4, classified as very high risk [32].

The high REBA score observed in Posture 1 is consistent with previous findings in manual concrete block production, where squatting and bending postures also yielded a REBA score of 11, classified as very high risk [33]. Workers reported musculoskeletal complaints in the back, arms, wrists, calves and thighs due to prolonged static loading in similar postures. These parallels reinforce that sustained squatting-bending positions impose considerable ergonomic risks across different manual industries, validating the present assessment results.

Following the REBA assessment, the OWAS method was performed to further classify postural strain. The identified OWAS assessment factors for Posture 1 are summarized in Table 3.

**Table 3**

Factors assessed in OWAS for posture 1.

No.	Factors	Identification
1	Back	Forming an angle of 30°
2	Arms	Both arms are under the shoulders
3	Legs	Both legs bent in a squatting position
4	Load	5 kilograms or 11 lbs

The OWAS analysis validated using ErgoFellow 3.0, produced a posture code of 2-1-5-1, corresponding to a risk level of 3 (moderate risk). According to the OWAS assessment table, back and leg positions were classified as high risk (scores of 3 and 4, respectively), while the arms were classified as low risk (score of 1) [32]. These results highlight that while REBA identified very high overall risk, OWAS emphasized localized high-risk areas, particularly in the lower limbs and spine. The alignment of both methods underscores the urgent need for targeted interventions, including posture adjustments and workstation redesign to mitigate long-term MSD risks.

### 3.3 Ergonomic assessment of Posture 2

Posture 2 corresponds to a standing position commonly adopted during welding tasks (Figure 2). This posture involves prolonged standing combined with repetitive upper-body movements, potentially leading to musculoskeletal strain. The REBA assessment for Posture 2 was conducted to evaluate ergonomic risk factors, including body angles, load handling, grip conditions and muscle activity (Table 4).



(a)



(b)



(c)

Fig. 2. Posture 2 (standing) from right, rear and left views.

**Table 4**

Factors assessed by REBA for Posture 2.

No.	Factors	Identification
1	Neck	Forming an angle of 30° and bending 30°
2	Trunk	Forming an angle of 4° and bending 9°
3	Legs	Both legs support the trunk
4	Load	5 kilograms or 11 lbs
5	Upper arm	Forming an angle of 11°
6	Forearm	Forming an angle of 96°
7	Wrist	Forming an angle of 18° and the palm is turned inward
8	Coupling	The rubber on the handle is peeling off
9	Activity	Welding in a static state

The assessment process assigned an initial score of 6 to Group A, which evaluates the neck, trunk and legs, and a score of 3 to Group B, which focuses on the upper arm, forearm and wrist. The final C score was recorded as 6, leading to a Final REBA Score of 7. This score indicates a moderate ergonomic risk (risk level 2),

suggesting that while Posture 2 does not pose an immediate danger, prolonged exposure without corrective interventions could contribute to musculoskeletal discomfort.

To further evaluate postural strain in Posture 2, the OWAS was performed. The assessment focused on key ergonomic factors, including back, arm, and leg positions, as well as the load handled by welders. The identified OWAS assessment factors are summarized in Table 5.

**Table 5**

Factors assessed in OWAS for posture 2.

No.	Factors	Identification
1	Back	In the straight position
2	Arms	Both arms are under the shoulders
3	Legs	Standing on both feet
4	Load	5 kilograms or 11 lbs

The manual OWAS analysis assigned a posture code of 1-1-2-1, corresponding to risk level 1, which is classified as low-risk. According to the OWAS classification, risk scores by body region were: back = 1 (low), arms = 1 (low) and legs = 2 (moderate) [32]. The ErgoFellow 3.0 validation confirmed identical results. This classification indicates a normal posture with no significant impact on the musculoskeletal system. The relatively low risk for Posture 2 is attributed to neutral spine alignment, balanced bilateral foot support and minimal trunk flexion, all of which reduce lumbar compression forces.

A comparison with previous literature provides additional context for interpreting the ergonomic risk classification of Posture 2 in the present study. As reported in [34], novice welders in a Malaysian technical institution exhibited an average REBA score of 9, classified as a high-risk category, primarily due to trunk flexion, neck bonding and varied lower limb positions observed during standing welding tasks.

In contrast, the standing posture assessed as Posture 2 in this study recorded a REBA score of 7, classified as moderate risk. The lower score is supported by the quantitative measurements presented in Table 4, which show minimal trunk flexion with slight bending, balanced bilateral foot support and moderate neck flexion. Upper limb angles and a light load of 5 kg further reduced physical demand. These favourable ergonomic factors collectively minimized lumbar compression forces and musculoskeletal strain, explaining the moderate risk classification compared to the higher-risk standing welding postures reported in [34].

Results from related research further indicate that even moderate-risk postures can contribute to musculoskeletal strain, when tasks are prolonged and repetitive [35]. Welders in that study exhibit high prevalence rates of lower back, shoulder and wrist pain, with significant associations between elevated REBA scores and self-reported discomfort. Additional risk factors such as long working hours and lack of physical activity exacerbated these outcomes, while protective

factors included work-rest breaks and higher job satisfaction. This evidence suggests that although Posture 2 demonstrates a reduced risk profile compared to previously reported standing welding postures, preventive ergonomic strategies remain essential to mitigate the long-term progression of work-related MSDs [36].

### 3.4 Ergonomic intervention and design evaluation

To mitigate the identified risks, a series of ergonomic interventions and design modifications was proposed and evaluated. For Posture 1, the primary target areas for posture improvement include the neck, trunk, forearms, wrists, and feet. The primary objective is to shift from a sitting-squatting to a proper sitting posture, which has been shown to reduce leg strain, minimize energy expenditure and improve blood circulation. Research suggests that working in a sitting position is preferable for tasks requiring precision and prolonged durations [37]. The seat design must allow variations in posture to accommodate movement flexibility [38].

A customized workbench was designed using Indonesian anthropometric data (Table 4) [39], ensuring comfort, safety, and ergonomic practicality for prolonged use (2–6 hours per component) (Figure 3). The bench height is determined based on the popliteal height of P50, while width and length are designed based on shoulder width and buttocks-popliteal distance using the large percentile (P95).

**Table 4**

Indonesian anthropometric data [39].

No.	Dimensions	5 <sup>th</sup>	50 <sup>th</sup>	95 <sup>th</sup>
1	Popliteal Height	38	43	49
2	Hip Width	28	35	43
3	Buttocks-Popliteal	31	40	48
4	Sitting Elbow Height	24	32	40
5	Standing Elbow Height	98	105	113

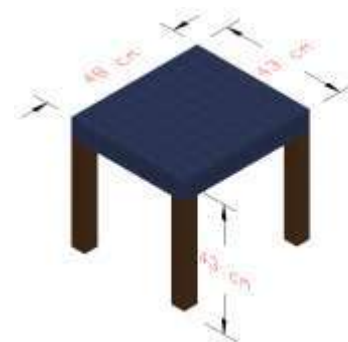

Fig. 3. Workbench design.

A proper worktable is also necessary to compensate for height variations when working in a sitting position. Sitting elbow height and popliteal height were used as references to design an optimal table height, tested through three percentile-based experimental heights:

- Small percentile: 62 cm
- Middle percentile: 75 cm
- Large percentile: 89 cm

The 3D Static Strength Prediction Program (3DSSPP) human model simulation confirmed that a table height

of 75 cm provides the most natural body positioning, as seen in Figure 4. The final worktable dimensions are 100 cm in length and 50 cm in width, constructed from metal or steel to withstand heavy loads (Figure 5).

After implementation, the redesigned workstation successfully reduced the REBA score to 6 (moderate risk, level 2) and the OWAS code to 1-1-1-1 (low risk, level 1). The 3DSSPP analysis validated this improvement, indicating an L4/L5 spinal load of 1789 N, which falls within the safe category. **The design optimization of an excavator driver cabin in [40], which included adjustments based on anthropometric data, resulted in a reduction of REBA scores, supporting the effectiveness of this intervention.**

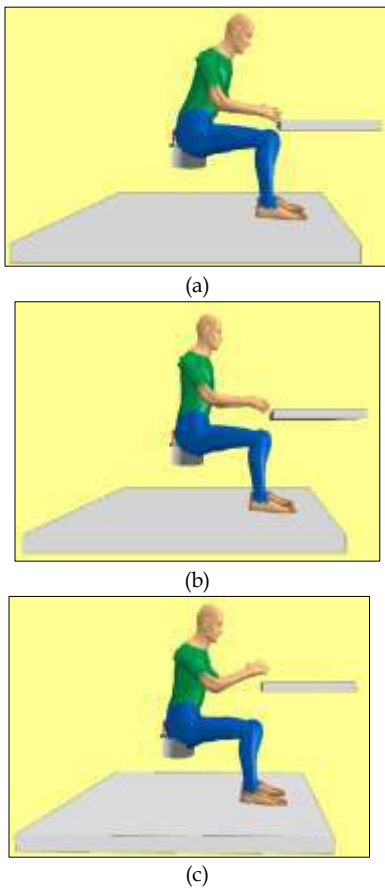

Fig. 4. Worktable height simulation: (a) 62, (b) 75 and (c) 89 cm



Fig. 5. Worktable Design

For Posture 2, improvements focused on adjusting the height of the small lathe, a primary workspace for standing welders. **Using the standing elbow height from the middle percentile (P50) of 105 cm, the small**

**lathe was raised by 5 cm from its previous height of 100 cm. The new height of 105 cm better aligns with ergonomic requirements.** The human model simulation confirmed improved posture ergonomics (Figure 6).



Fig. 6. Posture 2 improvement simulation.

This adjustment resulted in a reduced REBA score of 5 (moderate risk, level 2) and the OWAS code to 1-1-2-1 (low risk, level 1). The 3DSSPP analysis validated this improvement, indicating an L4/L5 spinal load of 1100 N (112 kg), which falls within the safe category.

In addition to Indonesian anthropometric data, actual measurements of the welders were collected for better customization (Table 5).

**Table 5**  
Anthropometric data for welders.

Anthropometric Data	Dimensions (cm)
Popliteal Height	47
Hip Width	52
Buttocks-popliteal	51
Sitting Elbow Height	28
Standing Elbow Height	105

Compared to standard Indonesian anthropometry, welders exhibited larger dimensions, particularly in popliteal height, hip width, and buttocks-popliteal distance (4 cm larger than standard data). **These deviations have direct implications for workbench ergonomics, as a fixed-height bench would not accommodate the full range of body sizes, potentially increasing awkward postures and localized muscle strain.** To address this, a hydraulic-adjustable bench with a height range of 38 – 49 cm was proposed (Figure 7). This configuration allows each user to adjust the bench height relative to their own popliteal and elbow height, thereby maintaining optimal elbow-table angles and reducing trunk flexion.

The hydraulic mechanism enables smooth and precise vertical movement by applying fluid pressure, allowing operators to finely set the seat height with minimal effort and high accuracy, without interrupting workflow. Hydraulics systems are widely recognized for their precision and control, which are critical in adjustable benches and ergonomic seats [41]. Hydraulics were selected over mechanical systems because they provide stable positioning, durability under heavy industrial use and ease of fine-tuning, making them more reliable in demanding

environments [42]. These qualities ensure that welders can quickly adapt the bench to their body dimensions and working posture, improving both comfort and safety [43].

Studies on user-furniture interaction found that ergonomic features such as adjustable seat height significantly enhance comfort and reduce muscle strain when customized to an individual's anthropometric profile [44]. Specifically, adjustable seat height reduced thigh pressure by 8.5% over prolonged periods, while maintaining postural stability and long-term usability through dynamic positioning. Adjustable designs also support dynamic postures, which are more effective in sustaining comfort and reducing fatigue than static positions. Previous ergonomic design studies in office settings also emphasize that adjustable features are critical for enhancing user comfort and reducing strain when tailored to anthropometric data [45]. These findings reinforce the universal importance of adjustability and support the adoption of a hydraulic-adjustable design for welding workstations where tasks last several hours.

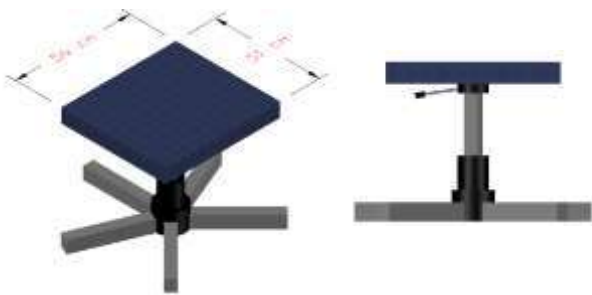

Fig. 7. Adjustable workbench for welders.

### 3.5 Preventing MSDs injuries

The primary strategy for preventing MSDs is the implementation of the redesigned workbench and seating system. This workstation was specifically developed to minimize awkward postures, reduce static loads and accommodate a wider range of worker anthropometry. To ensure maximum effectiveness, the redesigned table is integrated with a structured standard operating procedure (SOP) that combines engineering controls with participatory ergonomics [46], [47], behavioural safety [48] and continuous monitoring [49]. The proposed SOP is described as follows:

1. Early symptom reporting: workers are encouraged to report any discomfort promptly. The redesigned workbench, which incorporates adjustable height and seating support, makes it easier to identify whether improper adjustment contributes to symptoms [50]. Coupled with structured safety training and a positive reporting culture [51], early detection helps prevent minor discomfort from developing into chronic MSDs.
2. Supervisor inspection and anthropometric adjustment: supervisors are responsible for ensuring that the workbench height, seating

angle and footrest are adjusted to match each worker's anthropometry. Since the redesigned workstation is adjustable, proactive fitting reduces exposure to risk factors and has been shown to lower injury rates [52], [53].

3. Corrective measures: when symptoms or postural deviations are detected, corrective actions such as posture guidance and workstation reconfiguration are implemented [54]. The redesigned table allows quick modification of surface height and tool placement, reducing forward bending and shoulder elevation, two key contributors to MSDs.
4. Monitoring the progression of symptoms: digital tools and standardized instruments are employed to track worker conditions [55]. The redesigned workbench layout provides sufficient clearance and sensor-mounting options [56], supporting continuous monitoring of posture and workload.
5. Medical examinations: when symptoms persist despite workstation adjustments, a medical assessment is conducted [51]. Data from the adjustable workstation settings assist in identifying whether specific postures or loads are linked to worker discomfort, enabling more targeted clinical interventions.
6. Documentation and continuous improvement: in which diagnosis records are systematically utilized to refine workstation design, update training modules and sustain a feedback loop for long-term prevention [57].

### 3.6 Managerial implications and future research

This study offers clear managerial implications for heavy industrial settings. The integrated use of traditional ergonomic tools with digital human modeling provides a robust methodology for identifying and proactively addressing occupational risks. The significant reduction in MSDs risk for the sitting-squatting posture, as validated by both observational and simulation methods, provides a strong, quantifiable business case for investing in ergonomic workstations. This approach shifts safety from a reactive measure to a proactive strategy that can enhance worker well-being, increase productivity, and potentially reduce compensation costs.

From an economic perspective, investment in ergonomic workstations can yield long-term savings by reducing the incidence of MSD-related injuries, thereby lowering compensation claims, absenteeism and medical expenses. At the same time, improved comfort and safety are expected to enhance productivity and work quality, making such interventions a cost-effective strategy for industrial settings.

The validity of the simulation is supported by the well-established reliability of the 3DSSPP, developed by the University of Michigan [58]. 3DSSPP has been extensively applied in industrial ergonomics research

and validated against empirical biomechanical data, particularly for predicting spinal loads, joint moments and postural stresses. Its ability to replicate realistic human postures and estimate physiological responses provides a strong justification for its use as a valid tool to support the redesign of welding workstations in this study.

A key limitation of this study is its small sample size, especially for the initial NBM survey and anthropometric data collection. Future research should expand the study to a larger population and other industrial sectors to validate the generalizability of these findings. It would also be valuable to conduct a longitudinal study to measure the long-term impact of these ergonomic interventions on worker health and productivity. Beyond these methodological extensions, future studies may also explore advanced technological integrations such as wearable posture sensors and digital monitoring systems, which would enable real-time risk detection, proactive intervention and further optimization of ergonomic practices in dynamic industrial settings.

#### 4. Conclusions

This study examined the persistent ergonomic risks associated with welding activities, where specific postures were identified as contributing significantly to musculoskeletal discomfort. By applying both observational and digital simulation methods, the research identified the source of ergonomic strain and proposed evidence-based solutions. The redesign of the workstation demonstrated the value of anthropometry-driven modifications, enabling safer postures through an adjustable workbench and improved seating. For standing tasks, height adjustments of equipment offered measurable improvements in postural safety, showing that relatively simple engineering controls can yield meaningful ergonomic benefits. Beyond technical modifications, this study emphasized the integration of ergonomic interventions within a structured prevention framework. The proposed SOP, covering early symptom reporting, supervisor-led workstation adjustments, corrective actions, systematic monitoring, medical referral and continuous documentation, ensures that risk reduction is sustained through organizational practices. From a managerial perspective, these findings demonstrate that proactive ergonomic investment reduces MSDs, enhances worker health and lowers costs related to injury claims. Future research should validate these results with larger-scale data while exploring the integration of wearable posture sensors and digital monitoring for early detection and prevention.

#### Declaration statement

**Sanfransyul Arung Tasik:** Data Curation, Formal Analysis, Writing – Original Draft. **Rahmi Maulidya:** Conceptualization, Methodology, Supervision, Validation, Writing – Review & Editing. **Ika Wahyu**

**Utami:** Conceptualization, Supervision, Validation, Writing – Review, Editing & Revision. **Dian Mardi Safitri, Novia Rahmawati:** Validation, Writing – Review & Editing. **Anik Nur Habyba:** Literature Review, Supporting Analysis, Writing – Review.

#### Acknowledgement

The authors would like to express their gratitude to the welding workshop staff for their cooperation during field data collection. Special appreciation is extended to Universitas Trisakti for providing academic and administrative support throughout this research. The constructive feedback from reviewers also contributed significantly to improving the quality of this manuscript.

#### Disclosure statement

The authors declare no conflicts of interest.

#### Funding statement

The study was conducted independently without external financial support.

#### Data availability statement

The authors confirm that the data supporting the findings of this study are available within the article or its supplementary materials.

#### AI Usage Statement

This manuscript utilizes generative AI and AI-assisted tools to improve readability and language. All AI-generated content has been reviewed and edited by the authors to ensure accuracy and scientific integrity. The authors take full responsibility for the content and conclusions of this work and disclose the use of AI to maintain transparency and comply with publisher guidelines.

#### References





- [1] M. Z. Muktar, S. B. Shamsudin, K. A. Lukman, and M. S. Jeffree, "Assessment of Ergonomic Risk Levels and Working Performance of Pre-cast Construction Workers in Sabah," *Malaysian Journal of Public Health Medicine*, vol. 17, no. 2, pp. 151–158, 2017, [Online]. Available: <https://www.researchgate.net/publication/320014130>
- [2] P. H. Jukka, T. Tan, and B. Kiat, "GLOBAL ESTIMATES OF OCCUPATIONAL ACCIDENTS AND WORK-RELATED ILLNESSES 2017," Singapore, Sep. 2017. [Online]. Available: [www.wsh-institute.sg](http://www.wsh-institute.sg)
- [3] J. Park, Y. Kim, and B. Han, "Work Sectors with High Risk for Work-Related Musculoskeletal

- Disorders in Korean Men and Women,” *Saf Health Work*, vol. 9, no. 1, pp. 75–78, Mar. 2018, doi: 10.1016/j.shaw.2017.06.005.
- [4] M. F. Antwi-Afari, H. Li, D. J. Edwards, E. A. Pärn, J. Seo, and A. Y. L. Wong, “Biomechanical Analysis of Risk Factors for Work-related Musculoskeletal Disorders during Repetitive Lifting Task in Construction Workers,” *Autom Constr*, vol. 83, pp. 41–47, Nov. 2017, doi: 10.1016/j.autcon.2017.07.007.
- [5] M. S. Rahman and J. Sakamoto, “The Risk Factors for the Prevalence of Work-Related Musculoskeletal Disorders among Construction Workers: A Review,” Jun. 01, 2024, *Research Expansion Alliance (REA)*. doi: 10.22105/jarie.2023.413676.1561.
- [6] S. Kim, M. A. Nussbaum, and B. Jia, “Low back injury risks during construction with prefabricated (panelised) walls: Effects of task and design factors,” *Ergonomics*, vol. 54, no. 1, pp. 60–71, Jan. 2011, doi: 10.1080/00140139.2010.535024.
- [7] S. Bulduk, E. Ö. Bulduk, and T. Süren, “Reduction of Work-related Musculoskeletal Risk Factors Following Ergonomics Education of Sewing Machine Operators,” *International Journal of Occupational Safety and Ergonomics*, vol. 23, no. 3, pp. 347–352, Jul. 2017, doi: 10.1080/10803548.2016.1262321.
- [8] K. Wong and A. H. S. Chan, “Emerging Issues in Occupational Safety and Health,” Dec. 18, 2018, *MDPI*. doi: 10.3390/ijerph15122897.
- [9] N. D. Nath, R. Akhavian, and A. H. Behzadan, “Ergonomic Analysis of Construction Worker’s Body Postures using Wearable Mobile Sensors,” *Appl Ergon*, vol. 62, pp. 107–117, Jul. 2017, doi: 10.1016/j.apergo.2017.02.007.
- [10] D. Kee, “Systematic Comparison of OWAS, RULA, and REBA Based on a Literature Review,” Jan. 01, 2022, *MDPI*. doi: 10.3390/ijerph19010595.
- [11] D. Kee, “Comparison of OWAS, RULA and REBA for Assessing Potential Work-related Musculoskeletal Disorders,” *Int J Ind Ergon*, vol. 83, May 2021, doi: 10.1016/j.ergon.2021.103140.
- [12] M. GÓMEZ-GALÁN, J. PÉREZ-ALONSO, Á.-J. CALLEJÓN-FERRE, and J. LÓPEZ-MARTÍNEZ, “Musculoskeletal Disorders: OWAS Review,” *Ind Health*, vol. 55, no. 4, pp. 314–337, 2017.
- [13] K. Enez and S. S. Nalbantoğlu, “Comparison of Ergonomic Risk Assessment Outputs from OWAS and REBA in Forestry Timber Harvesting,” *Int J Ind Ergon*, vol. 70, pp. 51–57, Mar. 2019, doi: 10.1016/j.ergon.2019.01.009.
- [14] M. Hita-Gutiérrez, M. Gómez-Galán, M. Díaz-Pérez, and Á. J. Callejón-Ferre, “An Overview of REBA Method Applications in the World,” Apr. 02, 2020, *MDPI*. doi: 10.3390/ijerph17082635.
- [15] M. Joshi, V. Deshpande, and H. Shukla, “The investigation of ergonomic and energy intervention in roof sticks bending facility,” *International Journal of Mechanical and Production Engineering Research and Development*, vol. 9, no. Special Issue, pp. 220–225, 2019, [Online]. Available: <https://www.scopus.com/inward/record.uri?eid=2-s2.0-85074665227&partnerID=40&md5=7aca0b54e42e0839c9623e6983538651>
- [16] G. G. Reyes-Zárate, “A Digital REBA System Based on Kinect and Its Benefits for Ergonomic Assessment,” in *Smart Innovation, Systems and Technologies*, 2024, pp. 3–11. doi: 10.1007/978-981-99-7210-4\_1.
- [17] B. M. Kunar, M. Aruna, and M. B. Kar, “Postural analysis of dumper operators and construction workers – a case study,” *Journal of Mines, Metals and Fuels*, vol. 69, no. 6, pp. 180–185, 2021, doi: 10.18311/jmmf/2021/28525.
- [18] F. Colombo, “Ergonomia e organizzazione del lavoro,” *Rivista Italiana della Saldatura*, vol. 58, no. 6, pp. 817–822, 2006, [Online]. Available: <https://www.scopus.com/inward/record.uri?eid=2-s2.0-34147174369&partnerID=40&md5=d8f91c2a6e07bfab773d01dd71e6f1d6>
- [19] M. Caterino, M. Rinaldi, and M. Fera, “Digital ergonomics: an evaluation framework for the ergonomic risk assessment of heterogeneous workers,” *Int J Comput Integr Manuf*, vol. 36, no. 2, pp. 239–259, 2023, doi: 10.1080/0951192X.2022.2090023.
- [20] J. Zhong, V. Weistroffer, P. Maurice, C. Andriot, and F. Colas, “Interacting with a Torque-Controlled Virtual Human in Virtual Reality for Ergonomics Studies,” in *Proceedings - 2022 IEEE Conference on Virtual Reality and 3D User Interfaces Abstracts and Workshops, VRW 2022*, 2022, pp. 678–679. doi: 10.1109/VRW55335.2022.00190.
- [21] J. Seo, K. Yin, and S. Lee, “Automated Postural Ergonomic Assessment Using a Computer Vision-Based Posture Classification,” in *Construction Research Congress 2016: Old and New Construction Technologies Converge in Historic San Juan - Proceedings of the 2016 Construction Research Congress, CRC 2016*, 2016, pp. 809–818. doi: 10.1061/9780784479827.082.
- [22] L. Dulina, M. Kramárov, M. Krajčovič, and D. Plinta, “Ergonomic analysis and the tracking systems,” in *Ergonomics For People With Disabilities: Design For Accessibility*, 2018, pp. 135–144. doi: 10.2478/9783110617832-011.
- [23] A. Golabchi, S. Han, A. R. Fayek, and S. Abourizk, “Stochastic Modeling for Assessment of Human Perception and Motion Sensing Errors in Ergonomic Analysis,” *Journal of Computing in Civil Engineering*, vol. 31, no. 4, 2017, doi: 10.1061/(ASCE)CP.1943-5487.0000655.
- [24] S. Hignett and L. McAtamney, “Rapid Entire Body Assessment (REBA),” *Appl Ergon*, vol. 31,

- no. 2, pp. 201–205, Apr. 2000, doi: 10.1016/S0003-6870(99)00039-3.
- [25] B. Gajšek, A. Draghici, M. E. Boatca, A. Gaureanu, and D. Robescu, "Linking the Use of Ergonomics Methods to Workplace Social Sustainability: The Ovako Working Posture Assessment System and Rapid Entire Body Assessment Method," *Sustainability (Switzerland)*, vol. 14, no. 7, Apr. 2022, doi: 10.3390/su14074301.
- [26] O. Karhu, P. Kansii, and I. Kuorinka, "Correcting Working Postures in Industry: A Practical Method for Analysis," *Applied Ergonomics*, vol. 8, pp. 199–201, 1977.
- [27] N. Sarter, "3DSSPP: Background Information," 2020, <https://c4e.engin.umich.edu/tools-services/3dsspp-software/3dsspp-background-information/>.
- [28] A. D. Hall, N. J. La Delfa, C. Loma, and J. R. Potvin, "A Comparison Between Measured Female Linear Arm Strengths and Estimates from the 3D Static Strength Prediction Program (3DSSPP)," *Appl Ergon*, vol. 94, Jul. 2021, doi: 10.1016/j.apergo.2021.103415.
- [29] D. M. Safitri, N. C. Rizani, and F. Alexander, "Perancangan Fasilitas Kerja yang Ergonomis Stasiun Perakitan di PT X untuk Mengurangi Risiko Work-related Musculoskeletal Disorders," *J@TI Undip*, vol. III, no. 3, pp. 184–190, 2008.
- [30] FBFSistemas, "ErgoFellow 3.0," <https://www.fbfsistemas.com/ergonomics.html>.
- [31] C. P. Dewangan and A. K. Singh, "Ergonomic Study and Design of the Pulpit of a Wire Rod Mill at an Integrated Steel Plant," *Journal of Industrial Engineering*, vol. 2015, pp. 1–11, Feb. 2015, doi: 10.1155/2015/412921.
- [32] Tarwaka, *Ergonomi Industri Dasar-Dasar Pengetahuan Ergonomi dan Aplikasi di Tempat Kerja: Penilaian Risiko Gangguan Sistem Muskuloskeletal*, II. Surakarta: Harapan Press, 2019.
- [33] L. Widodo, S. Ariyanti, and A. Jason, "Ergonomic Intervention to Improve the Productivity of Brick Press Tool in Small and Medium Enterprise (SME) Akheng Kobar," in *IOP Conference Series: Materials Science and Engineering*, Institute of Physics Publishing, May 2020. doi: 10.1088/1757-899X/847/1/012057.
- [34] K. F. Bin Salleh, S. M. Fadzil, and M. Y. M. Daud, "Ergonomic Posture Assessment Approaches for New Welder: A Study in Technical Institution," *Jurnal Kejuruteraan*, vol. 35, no. 5, pp. 1045–1054, Sep. 2023, doi: 10.17576/jkukm-2023-35(5)-06.
- [35] C. Elvis, N. France, and E. Patience, "Risk factors for work-related musculoskeletal disorders among welders in the informal sector under resource constrained settings," *Work*, vol. 72, no. 1, pp. 239–252, 2022, doi: 10.3233/WOR-205275.
- [36] A. J. Van Der Beek et al., "A research framework for the development and implementation of interventions preventing work-related musculoskeletal disorders," *Scand J Work Environ Health*, vol. 43, no. 6, pp. 526–539, 2017, doi: 10.5271/sjweh.3671.
- [37] E. Grandjean, *Fitting the Task to the Man*, IV. London: Taylor & Francis Inc, 1993.
- [38] S. Pheasant, *Body Space, Anthropometry, Ergonomics and Design*. London: Taylor & Francis Inc, 1998.
- [39] Antropometri Indonesia, "Rekap Data Antropometri Indonesia," [https://antropometriindonesia.org/index.php/detail/artikel/4/10/data\\_antropometri](https://antropometriindonesia.org/index.php/detail/artikel/4/10/data_antropometri).
- [40] K. Koushik Balaji and M. S. Alphin, "Computer-aided human factors analysis of the industrial vehicle driver cabin to improve occupational health," *Int J Inj Contr Saf Promot*, vol. 23, no. 3, pp. 240–248, 2016, doi: 10.1080/17457300.2014.992351.
- [41] P. Dudziński and A. Skurjat, "Impact of Hydraulic System Stiffness on Its Energy Losses and Its Efficiency in Positioning Mechanical Systems," *Energies (Basel)*, vol. 15, no. 1, 2022, doi: 10.3390/en15010294.
- [42] A. Vacca and G. Franzoni, *Hydraulic Fluid Power: Fundamentals, Applications, and Circuit Design*. 2021. [Online]. Available: <https://www.scopus.com/inward/record.uri?eid=2-s2.0-85126554373&partnerID=40&md5=87acde350bc3525e7d4dae5fc55d0498>
- [43] J. M. N. Silva et al., "Evaluation of the ergonomic changes made in the presses sector in an metallurgical industry," in *Occupational Safety and Hygiene - Proceedings of the International Symposium on Occupational Safety and Hygiene, SHO 2013*, 2013, pp. 347–350. doi: 10.1201/b14391-72.
- [44] M. Gao, "Analyze the physical interaction between the user and the furniture design to optimize comfort and functionality," *MCB Molecular and Cellular Biomechanics*, vol. 21, no. 2, 2024, doi: 10.62617/mcb457.
- [45] F. T. Basaria, M. K. Perdana, C. Harito, V. Puspita, R. Shafira, and S. A. Salsabilla, "Sustainable and Ergonomic Office Chair: ROSA Insights for Improved Workplace Health," in *IOP Conference Series: Earth and Environmental Science*, Institute of Physics, 2025. doi: 10.1088/1755-1315/1488/1/012056.
- [46] A. Choobineh et al., "A multilayered ergonomic intervention program on reducing musculoskeletal disorders in an industrial complex: A dynamic participatory approach," *Int J Ind Ergon*, vol. 86, 2021, doi: 10.1016/j.ergon.2021.103221.
- [47] E. M. Capodaglio, "Participatory ergonomics for the reduction of musculoskeletal exposure of maintenance workers," *International Journal of*

- Occupational Safety and Ergonomics*, vol. 28, no. 1, pp. 376–386, 2022, doi: 10.1080/10803548.2020.1761670.
- [48] R. W. Bunch, “An integrated ergo-behavioral approach to prevention of musculoskeletal disorders (MSDs),” in *ASSE Professional Development Conference and Exposition 2004*, 2004. [Online]. Available: <https://www.scopus.com/inward/record.uri?eid=2-s2.0-85058445175&partnerID=40&md5=d7d2b309c082b5ac413c04f0b45404f4>
- [49] J. Onyinyechukwu Adibeli, Y.-K. Liu, N. Junior Awodi, A. Kipkosgei Chepkwony, and A. Ayodeji, “Ergonomic analysis in nuclear decommissioning: A comprehensive path planning strategy for workers well-being,” *Nuclear Engineering and Design*, vol. 426, 2024, doi: 10.1016/j.nucengdes.2024.113409.
- [50] C. O. Soares, B. F. Pereira, M. V Pereira Gomes, L. P. Marcondes, F. De Campos Gomes, and J. S. De Melo-Neto, “Preventive factors against work-related musculoskeletal disorders: Narrative review,” *Revista Brasileira de Medicina do Trabalho*, vol. 17, no. 3, pp. 415–430, 2019, doi: 10.5327/Z1679443520190360.
- [51] M. Kyung, S.-J. Lee, L. M. Wagner, C. Harris-Adamson, and O. Hong, “Factors Associated With Reporting Attitudes of Work-Related Musculoskeletal Disorders Among Direct Care Workers in South Korea,” *Workplace Health Saf*, vol. 72, no. 8, pp. 345–353, 2024, doi: 10.1177/21650799241247078.
- [52] W. S. Shaw, M. M. Robertson, R. K. McLellan, S. Verma, and G. Pransky, “A controlled case study of supervisor training to optimize response to injury in the food processing industry,” *Work*, vol. 26, no. 2, pp. 107–114, 2006, [Online]. Available: <https://www.scopus.com/inward/record.uri?eid=2-s2.0-33645305458&partnerID=40&md5=179e3822c9d5ee24d4fc640b8b3e317b>
- [53] D. C. Cole, S. Hogg-Johnson, M. Manno, S. Ibrahim, R. P. Wells, and S. E. Ferrier, “Reducing musculoskeletal burden through ergonomic program implementation in a large newspaper,” *Int Arch Occup Environ Health*, vol. 80, no. 2, pp. 98–108, 2006, doi: 10.1007/s00420-006-0107-6.
- [54] X. Jin et al., “Ergonomic interventions to improve musculoskeletal disorders among vehicle assembly workers: a one-year longitudinal study,” *BMC Public Health*, vol. 25, no. 1, 2025, doi: 10.1186/s12889-025-21798-1.
- [55] C. Lanhers, B. Pereira, G. Garde, C. Maublant, F. Dutheil, and E. Coudeyre, “Evaluation of ‘I-Preventive’: a digital preventive tool for musculoskeletal disorders in computer workers—a pilot cluster randomised trial,” *BMJ Open*, vol. 6, no. 9, 2016, doi: 10.1136/BMJOPEN-2016-011304.
- [56] A. Greco, M. Caterino, M. Fera, and S. Gerbino, “Digital twin for monitoring ergonomics during manufacturing production,” *Applied Sciences (Switzerland)*, vol. 10, no. 21, pp. 1–20, 2020, doi: 10.3390/app10217758.
- [57] J. Oakman and W. Macdonald, “The APHIRM toolkit: an evidence-based system for workplace MSD risk management,” *BMC Musculoskeletal Disord*, vol. 20, no. 1, p. 504, 2019, doi: 10.1186/s12891-019-2828-1.
- [58] N. Sarter, “3DSSPP: Background Information,” [https://c4e.engin.umich.edu/tools-services/3dsspp-software/3dsspp-background-information/?utm\\_source=chatgpt.com](https://c4e.engin.umich.edu/tools-services/3dsspp-software/3dsspp-background-information/?utm_source=chatgpt.com).

### Author Information

	<b>Sanfransyul Arung Tasik</b> received his bachelor's degree in Industrial Engineering from Universitas Trisakti, Indonesia. His research interests include ergonomics and digital human modelling.
	<b>Rahmi Maulidya</b> is a lecturer in the Department of Industrial Engineering, Universitas Trisakti, Indonesia. She earned her doctoral degree in Industrial Engineering from Institut Teknologi Bandung, Indonesia. Her research interests include production scheduling, supply chain management, lean manufacturing and sustainable product-service systems.
	<b>Ika Wahyu Utami</b> is a Junior Lecturer in the Department of Industrial Engineering, Universitas Trisakti, Indonesia. She received her master's degree in Earth Sciences from National Central University, Taiwan. Her research interests include geophysics, environmental studies, ergonomics and IoT-based instrumentation.
	<b>Dian Mardi Safitri</b> is a researcher in industrial ergonomics and safety, associated with the Center of Excellence for Ergonomics, Occupational Health and Safety at Universitas Trisakti. She completed her doctoral degree in Industrial Engineering from Universitas Indonesia, focusing on advancing knowledge and practices within her field of expertise.
	<b>Novia Rahmawati</b> is a Lecturer in the Study Program of Industrial Management, College of Vocational Studies, IPB University, Indonesia. She received her master's degrees in industrial engineering from Institut Teknologi Bandung and from National Taiwan University of

	<p>Science and Technology (NTUST), Taiwan. Her research interests include ergonomics, usability evaluation, human-computer interaction, and supply chain management.</p>
	<p><b>Anik Nur Habyba</b> is a lecturer in the Department of Industrial Engineering, Universitas Trisakti, Indonesia. Her research interests are in Kansei Engineering, Data Mining, Quality Engineering, Applied Statistics, and Industrial Management. She is currently a PhD student at the Department of Industrial Engineering and Management, Yuan Ze University, Taiwan. She can be reached at <a href="mailto:anik@trisakti.ac.id">anik@trisakti.ac.id</a> and <a href="mailto:s1148904@mail.yzu.edu.tw">s1148904@mail.yzu.edu.tw</a>.</p>

**Respond form**

Authors are required to respond to all comments from the Reviewer and Editor. Authors must indicate in the revised manuscript the sections that have been revised.

**Reviewer #1**

No	Comments	Respond
1	Introduction: Does the gap analysis in the introduction effectively position the study within the wider field, demonstrating its relevance and necessity? → <i>Yes, but the authors have not written it well, and there are several parts that could be improved.</i>	We have revised the gap analysis in the Introduction to ensure better clarity and logical flow. The revised text now more explicitly highlights the shortcomings of previous studies, positions our work within the broader ergonomic research field, and justifies the necessity of combining REBA, OWAS, and 3DSSPP for welding posture improvement.
2	Introduction: Does the introduction underscore the research’s contributions, detailing how its findings enhance understanding or offer fresh perspectives to the field? → <i>No</i>	We have now added a clear statement of the study’s contributions in the final part of the Introduction. The revisions emphasize how integrating observational ergonomic tools with digital human modeling provides fresh insights into posture redesign, and how this approach contributes to advancing ergonomic intervention in heavy industrial welding tasks.
3	Results and Discussion: Please confirm whether the results are presented clearly, ensuring coherence with the title and effectively addressing the research problem. → <i>Yes, but the authors have not written it well, and there are several parts that could be improved.</i>	We have revised the Results and Discussion section to improve clarity and coherence. The flow of findings has been streamlined to ensure direct alignment with the research objectives and title. We also improved transitions between REBA/OWAS assessments and 3DSSPP simulations for better readability.
4	Conclusions: Please confirm whether the conclusion section effectively synthesizes the key findings into a clear and significant narrative, emphasizing the study’s contributions to the broader field, rather than merely recapping content or repeating the research problem. → <i>Yes, but the authors have not written it well, and there are several parts that could be improved.</i>	The Conclusion section has been revised to provide a more integrated synthesis of the study’s findings. Instead of simply repeating results, the revised conclusion emphasizes broader contributions, including how combining digital human modeling with observational methods strengthens ergonomic analysis. We also added implications for worker health, productivity, and future research opportunities.
	In subchapter 4.1 it is necessary to explain each dimension used to design the table and what percentile is used. The length and width of the table should also consider the size of the workpiece.	We have revised the subchapter to provide a detailed explanation of each dimension used in the table design. Specifically, we now clarify the use of anthropometric percentiles (P50 for height with an additional allowance, P95 for length and width) and explicitly note that the table’s length and width were adjusted to accommodate the size of the welding workpiece.
	In sub-chapter 4.1 the design of the welding chair and table needs to be improved to make it more comfortable for the welder operator. The height of the chair should consider how the operator can weld on the table easily, so that the height of the chairs in the workshop is higher than the chairs for studying, by considering the position of the operator's elbow to the table.	We have revised the description of the welding chair and table by incorporating ergonomic principles. The height of the chair is now explained in relation to the operator’s elbow-to-table angle, with justification on why workshop chairs require greater height than study chairs. These revisions aim to improve clarity

		regarding comfort and usability for welding tasks.
	In the Discussion chapter, Subchapter 4.5 Preventing MSDs needs to be fixed. The proposal to lower the MSDs should focus on the table that has been designed, but in this proposal there is no mention of the designed table but instead proposes other things that were not discussed in the previous chapters.	We have revised the subchapter 4.5 into 3.5 to ensure alignment with the preceding sections. The discussion now focuses directly on how the redesigned welding table contributes to reducing MSD risks. Unrelated proposals have been removed, and the prevention strategy is now clearly linked to the ergonomic redesign presented earlier.
	Sub-chapters 4.4 and 4.6 are not discussed and processed in the previous chapter, they should not be included in the discussion.	Subchapters 4.4 and 4.6 have been removed from the manuscript to maintain consistency and coherence between the Results and Discussion sections.

**Reviewer #2**

No	Comments	Respond
1	Abstract: Background and problem statement not included. Reviewer suggests: <i>Add the issue at the beginning of the paragraph.</i>	We have revised the Abstract to include the background and problem statement at the very beginning, so that the research issue is clearly introduced before describing the method and findings.
2	Introduction: Literature review of past studies not well written, needs improvement.	We have revised the literature review in the Introduction to ensure better organization and clarity. The narrative now highlights the state-of-the-art more systematically and emphasizes the knowledge gap our research addresses.
3	Introduction: Methods used by other researchers for similar problems not described.	We have added explanations of methods used in previous ergonomic and workstation design studies. A clear rationale is now provided for choosing our selected method over these alternatives.
4	Introduction: Contributions not stated. Reviewer suggests: <i>Add the research contribution.</i>	We have revised the last paragraph of the Introduction to explicitly outline the research contributions, including methodological novelty, ergonomic implications, and practical impact on reducing musculoskeletal risks.
5	Introduction: Citation style not IEEE. Example: Hita-Gutiérrez et al. (2020).	We have carefully checked and corrected all in-text citations and references to fully comply with IEEE citation style.
6	Introduction: The last two paragraphs and Table 1 should be placed in Results and Discussion.	We have moved the last two paragraphs and Table 1 to the Results and Discussion section, ensuring a more logical manuscript structure.
7	Results & Discussion: No comparisons with other studies. Reviewer suggests: <i>Include several comparisons with other studies. If they align, explain why; if not, explain why.</i>	We have added comparative analysis with similar studies. The revised discussion explains why our findings align or differ, supported by contextual factors such as operator anthropometry, task demands, and environmental conditions.
8	Results & Discussion: Add managerial implications.	A new subsection on managerial implications has been added, highlighting how the redesigned workstation can be applied in vocational

		9training centers and small-scale industries to enhance productivity and occupational safety.
9	Conclusion: Synthesizes findings but needs improvement.	The Conclusion has been rewritten to clearly synthesize the main findings, emphasize contributions, and highlight how this study expands knowledge in ergonomic workstation design for welding.
10	References: Relevant, but several can be improved.	We have updated the References by adding more recent and directly relevant studies. All references have been revised for accuracy and consistency in IEEE format.

### Editorial Board

No	Comments	Respond
1	JISS policy: remove research location from Introduction (last 2 paragraphs).	We have removed the last two paragraphs in the Introduction that explicitly mention the research location, and revised them to emphasize the methodological approach and broader relevance of the study.
2	Abstract: add background and problem before objective.	The Abstract has been revised to include a clear background and problem statement at the beginning, before stating the research objectives.
3	References and citations must use IEEE style.	All in-text citations and references have been checked and reformatted according to the IEEE style. Previous non-IEEE forms (e.g., "Hita-Gutiérrez et al. (2020)") have been corrected.
4	After describing the study approach (REBA, OWAS, VHM, 3DSSPP), add advantages compared to other approaches.	A new paragraph has been added in the introduction, after the methodological contribution statement, highlighting the advantages of using REBA, OWAS and VHM compared to conventional ergonomic assessment approaches.
5	Paragraph about research location ("This research was conducted at...") should be moved to Materials and Methods or Results.	This paragraph has been moved to the Materials and Methods section.
6	Paragraph on preliminary assessment with Nordic Body Map should be moved.	The NBM paragraph has been relocated to the Materials and Methods section.
7	Table 1 should be relocated and justify why only 1 observation is made and generalized.	Table 1 has been moved to the Materials and Methods section. We have added justification explaining the observation process, why the welding operator was selected, and why high NBM scores from this operator were relevant as a critical case study.
8	Remove irrelevant software screenshots; replace with meaningful data/visualization.	All non-informative software screenshots have been removed. We have replaced them with meaningful visualizations that directly present the ergonomic simulation results.
9	Discussion lacks explanation of results (e.g., design in Figure 11, use of adjustable features).	Additional explanation has been added to clarify the rationale behind the proposed design, particularly the need for adjustable features to accommodate

		operator anthropometric variability and minimize postural risks.
10	No comparative discussion with other studies.	We have included comparisons with relevant recent studies. The discussion now explains similarities and differences, with justifications based on task context, anthropometric variations, and methodological differences.
11	Add managerial implication sub-section, including justification of simulation validity.	A new sub-section on Managerial Implications has been added. It discusses how the proposed simulation-based design can reduce workload and improve occupational safety, with justification for the trustworthiness of the 3DSSPP simulation results.
12	Conclusion should not repeat results or numbers; must highlight problem solved, improvements, implications, limitations, and future research.	The Conclusion has been fully revised. It now focuses on the problem solved, key improvements made, implications for ergonomics and industrial engineering, limitations of the study, and suggestions for future research.
13	References must be improved; minimum 30 journal/proceeding papers in English.	The References list has been updated. Now more than 30 references from reputable English-language journals and proceedings (within the last 10 years) have been included.
14	IMPORTANT: Use the latest JISS template.	The manuscript has been reformatted using the latest official JISS template.
15	IMPORTANT: Use red font for all revised parts.	All revisions in the manuscript have been marked with red font to facilitate review.
16	IMPORTANT: At least 30 recent ( $\leq 10$ years) references; 70% must be English journal/proceedings.	This requirement has been met. The updated reference list contains more than 30 references, with over 70% sourced from English-language journals and proceedings.
17	IMPORTANT: Provide high-resolution figures.	All figures have been replaced with high-resolution versions (sufficient DPI) for publication quality.
18	IMPORTANT: Complete metadata (authors, order, affiliations, etc.).	The metadata section has been completed according to the journal template, including correct author names, order, and affiliations.
19	IMPORTANT: Add mandatory statements (Declaration, Acknowledgment, Disclosure, Funding, Data Availability, AI Usage).	All required statements have been added, following the examples in the Author Guidelines.
20	IMPORTANT: Complete Author Information section as per latest template.	The Author Information section has been revised and completed according to the latest template requirements.
21	In the methodology section, please provide stronger justification for why an in-depth observation of a single welder (with a high NBM score) is sufficient as a critical case study for designing this intervention.	We have revised the methodology section to provide a stronger justification. We explain that although several workers were surveyed, only the welder consistently recorded a substantially higher NBM score and reported musculoskeletal discomfort across multiple body regions. This case was therefore selected as a critical case study, representing the worst-case scenario of ergonomic risk. Interventions designed for this high-risk posture are expected to

		also provide insights transferable to less extreme working conditions.
22	In Figure 7, the adjustable bench design is presented. Since the text mentions a hydraulic system, please add one or two sentences explaining briefly how the adjustment works and why hydraulics were chosen (e.g., ease of use, precision).	We now provide a short explanation that the hydraulic mechanism enables smooth vertical adjustment, allowing welders to fine-tune the bench height with minimal effort and high accuracy. Hydraulics were chosen over mechanical systems because they ensure stable positioning, durability under heavy industrial use and ease of fine-tuning, which are essential for comfort and safety during long welding tasks.
23	In the Discussion (Managerial Implications), it would be useful to add a short paragraph on the potential economic impacts of investing in this ergonomic workstation, such as reduced injury compensation costs, increased productivity, or a qualitative cost-benefit perspective.	We have included a paragraph discussing the potential economic impacts. The new text explains that investment in ergonomic workstations can yield long-term savings by lowering injury compensation costs, reducing absenteeism and minimizing medical expenses. At the same time, improved comfort and safety are expected to enhance productivity and work quality, providing a qualitative cost-benefit justification for industrial organizations. This addition highlights both the economic and operational advantages of ergonomic intervention.