

BUKTI REVIEW DAN CORRESPONDING AUTHOR
SYARAT KHUSUS UNTUK PENGUSULAN JABATAN AKADEMIK
UNIVERSITAS TRISAKTI



Judul Paper	:	High Stability Single-Port Dual Band Microwave Sensor Based on Interdigital Capacitor Structure With Asymmetry Branch Feedline
Nama Penulis	:	Syah Alam ; Indra Surjati; Lydia Sari; Raden Deiny Mardian; Teguh Firmansyah; Muhammad Iqbal; Slamet Widodo; Mudrik Alaydrus; Zahriladha Zakaria
Nama Corresponding Author	:	Syah Alam
Nama Jurnal / ISSN	:	IEEE Access / 2475-1472
Volume / Nomor / Tahun	:	Vol. 13 / No.1 / pp. 24576 – 24586/ Februari 2025
Url Jurnal	:	https://ieeexplore.ieee.org/xpl/RecentIssue.jsp?punumber=6287639
Doi	:	https://doi.org/10.1109/ACCESS.2024.3425159
Quartile/ SJR/ Impact Factor / Publisher	:	Q1 / SJR = 0.96 / IF = 3.4 / IEEE
Jenis Dokumen / Jabamik	:	Syarat Khusus / Profesor

REKAM JEJAK PUBLIKASI DARI PROSES *SUBMISSION* → *PUBLISHED*

No	Tahapan	Keputusan	Tanggal
1.	1 st submission	Naskah diterima oleh editor dan dilanjutkan untuk proses peer review	05 Desember 2024
2.	1 st decision	Major Revision	19 Desember 2024
3.	2 nd submission (Revision 1)	Minor Revision	03 Januari 2025
4.	Accepted	Naskah diterima	27 Januari 2025
5.	Published (early access)	Naskah dipublikasikan pada versi early access	06 Februari 2025
6.	Published full version	Naskah dipublikasikan pada Vol. 13 / No.1 / pp. 24576 – 24586	06 Februari 2025

1st submission → Major Revision

IEEE Access
Regular Manuscript

High Stability Single-Port Dual Band Microwave Sensor Based on Interdigital Capacitor Structure with Asymmetry Branch Feedline

Submission Status	Rejected	Learn about what to do if your manuscript was rejected.
Manuscript ID	Access-2024-48908	
Rejected On	19 December 2024 by Editorial Office	
Submitted On	5 December 2024 by Syah Alam	

[Submission overview](#) →

2nd submission → Accepted

IEEE Access
Regular Manuscript

High Stability Single-Port Dual Band Microwave Sensor Based on Interdigital Capacitor Structure with Asymmetry Branch Feedline

Submission Status	Accepted	Learn about what happens once your article has been accepted.
Manuscript ID	Access-2025-00351	
Accepted On	31 January 2025 by Editorial Office	
Submitted On	31 January 2025 by Syah Alam	

[Submission overview](#) →



Assoc. Prof. Syah Alam S Pd, MT, PhD <syah.alam@trisakti.ac.id>

IEEE Access - Manuscript ID Access-2024-48908

1 message

1st submission

IEEE Access <onbehalf@manuscriptcentral.com>

Thu, Dec 5, 2024 at 11:19 PM

Reply-To: ieeeaccess@ieee.org

To: syah.alam@trisakti.ac.id, indra@trisakti.ac.id, lydia_sari@trisak.ac.id, deiny.wp@gmail.com, r.deiny@ui.ac.id, deiny_wp@trisakti.ac.id, teguhfirmansyah@untirta.ac.id, muh.iqbal@itb.ac.id, mudrikalaydrus@mercubuana.ac.id, zahriladha@utem.edu.my

05-Dec-2024

Dear Authors,

Your manuscript entitled "High Stability Single-Port Dual Band Microwave Sensor Based on Interdigital Capacitor Structure with Asymmetry Branch Feedline" has been successfully submitted online and is presently being given full consideration for publication in IEEE Access.

If you are receiving this email, that means you are listed as an author. If you do **not** approve of being listed as a co-author on this article, please reach out to ieeeaccess@ieee.org as soon as possible.

As a reminder, IEEE Access is a fully open access journal. Open Access provides unrestricted access to published articles via IEEE *Xplore*. In lieu of paid subscriptions, authors are required to pay an article processing charge of \$1,995 (plus applicable local taxes) after the article has been accepted for publication.

Your manuscript ID is Access-2024-48908. Please mention the manuscript ID in all future correspondence to the IEEE Access Editorial Office. The submitting author can view the manuscript status at any time by checking their author dashboard on the [IEEE Author Portal](#). If the submitting author needs to update their email address after submission, please reach out to ieeeaccess@ieee.org so we can assist you in doing so.

** Please note that any change to the author list after the article has been submitted is considered rare and exceptional, and the decision to allow such changes rests with the Editor. Once the list and order of authors has been established, the list and order of authors should not be altered without permission of all living authors of that article and will still be subject to editorial review.

Thank you again for submitting your manuscript to IEEE Access.

Sincerely,

IEEE Access Editorial Office

1st decision

Decision letter (Initial Submission)

High Stability Single-Port Dual Band Microwave Sensor Based on Interdigital Capacitor Structure with Asymmetry Branch Feedline

Subject IEEE Access - Decision on Manuscript ID Access-2024-48908

Date sent 19 December 2024 at 16:09 GMT+7

From ieeeaccess@ieee.org

To > [Show 11 addresses](#)

CC wsh.zhao@gmail.com

19-Dec-2024

Dear Dr. Alam:

I am writing to you regarding manuscript # Access-2024-48908 entitled "High Stability Single-Port Dual Band Microwave Sensor Based on Interdigital Capacitor Structure with Asymmetry Branch Feedline" which you submitted to IEEE Access.

Your article was peer reviewed with interest but has not been recommended for publication in its current form. We strongly encourage you to address the reviewers' concerns, which can be found at the bottom of this letter, and resubmit your article to IEEE Access once you have updated it

accordingly.

Please note that IEEE Access has a binary peer review process. Therefore, to uphold quality to IEEE standards, an article is rejected even if it requires minor edits.

When updating your manuscript, you should elaborate on your points and clarify with references, examples, data, etc. If you disagree with any technical points the reviewers have made, please include your counterarguments in your response to the reviewers (more information detailed below) and work this into the updated manuscript.

Also, note that if a reviewer suggested references, you should only add those that are relevant to your work if you feel they strengthen your article. Recommending references to specific publications is not appropriate for reviewers and you should report excessive cases to ieeeaccessEIC@ieee.org. Authors are not obligated to cite articles that are recommended by the reviewers, and the final decision on the article will not be influenced by whether or not authors cite these suggested references.

If the updated manuscript is determined not to have addressed all of the previous reviewers' concerns, or if the Associate Editor still has substantial technical concerns, the article may be rejected and no further resubmissions will be allowed.

When you are ready to resubmit your updated article, you can do so in the [IEEE Author Portal](#). When you log into the IEEE Author Portal you will see the title of the rejected article and the option to "Start Resubmission".

Upon resubmission you will be asked to upload the following 3 files:

- 1) A document containing your response to reviewers from the previous peer review. The "response to reviewers" document (template attached) should have the following regarding each comment: a) Reviewer's concern, b) your response to the concern, c) your action to remedy the concern. **The document should be uploaded with your manuscript files under "*Author's Response Files*."**
- 2) Your updated manuscript with all your individual changes highlighted, including grammatical changes (e.g. preferably with the yellow highlight tool within the pdf file). This file should be uploaded with your manuscript files as "*Highlighted PDF*."
- 3) A clean copy of the final manuscript (without highlighted changes) submitted as a Word or LaTeX file, and as a PDF, both submitted as the "*Main Manuscript*."

****IMPORTANT:** Please see the attached Resubmission Checklist that details all the items listed above. Please utilize this checklist to ensure you have made the necessary edits to your manuscript, and to ensure you have all the necessary files prepared prior to resubmission.

***** AUTHOR LIST CHANGES:** If your revised manuscript has an updated author list, you will need to submit a formal request to the Editor by completing the attachment labelled 'Request for Byline Change,' and uploading it as '*Request for byline change form*.' This should include a DETAILED justification explaining each author's contribution(s) to the work. Change in the author list is considered rare and exceptional, and the decision to allow such changes rests with the Editor. Once the list and order of authors has been established, the list and order of authors should not be altered without permission of all living authors of that article.

We sincerely hope you will update your manuscript and resubmit soon. Please contact me if you have any questions.

Thank you for your interest in IEEE *Access*.

Sincerely,

Prof. Wen-Sheng Zhao
Associate Editor, IEEE *Access*
wsh.zhao@gmail.com

Reviewers' Comments to Author:

Reviewer: 1

Comments:

The explanation of the paper is good. However, I don't think the prototype described in the paper is a sensor. To me, it appears to be an antenna (single port) designed for multiband operations. Additionally, in Figure 6(c), it seems that the antenna incorporates a superstrate for gain enhancement applications.

Additional Questions:

Please confirm that you have reviewed all relevant files, including supplementary files and any author response files, which can be found in the "View Author's Response" link above (author responses will only appear for resubmissions): Yes, all files have been reviewed

- 1) Does the paper contribute to the body of knowledge?: Yes
- 2) Is the paper technically sound?: Yes
- 3) Is the subject matter presented in a comprehensive manner?: Yes
- 4) Are the references provided applicable and sufficient?: Yes
- 5) Are there references that are not appropriate for the topic being discussed?: Yes
- 5a) If yes, then please indicate which references should be removed.:

Reviewer: 2

Comments:

The characterization of solid material permittivity at dual frequencies using a dual-band resonator sensor, with improved stability and high performance, presented in this manuscript is intriguing. Therefore, I recommend considering the publication of this work in IEEE *Access*, with some

suggested improvements.

Please take the following comments into account to enhance the quality of your manuscript:

1. Include expressions that help estimate the dual-band resonant frequencies using the proposed IDC resonator structure.
2. How did you calculate the component values in the equivalent circuit?
3. Please consider adding the following relevant works in the literature review of the introduction and comparison table.

"High-Accuracy Complex Permittivity Characterization of Solid Materials Using Parallel Interdigital Capacitor- Based Planar Microwave Sensor."
10.1109/JSEN.2020.3041014

"Design and Optimization of Interdigitated Microwave Sensor for Multidimensional Sensitive Characterization of Solid Materials."
10.1109/JSEN.2021.3105410

Additional Questions:

Please confirm that you have reviewed all relevant files, including supplementary files and any author response files, which can be found in the "View Author's Response" link above (author responses will only appear for resubmissions): Yes, all files have been reviewed

- 1) Does the paper contribute to the body of knowledge?: Yes
- 2) Is the paper technically sound?: Yes
- 3) Is the subject matter presented in a comprehensive manner?: Yes
- 4) Are the references provided applicable and sufficient?: Can be improved.
- 5) Are there references that are not appropriate for the topic being discussed?: No
- 5a) If yes, then please indicate which references should be removed.:

If you have any questions, please contact article administrator: Ms. Suhasini Das das.suhasini@ieee.org

Powered by **Research Exchange Submission** © Research Exchange

[Privacy Policy](#) | [Cookie Preferences](#) | [Terms](#) | [Help](#)

[IEEE Privacy Policy](#) | [Contact us](#)

Original Manuscript ID: *Access-2024-4890*

Original Article Title: *“High Stability Single-Port Dual Band Microwave Sensor Based on Interdigital Capacitor Structure with Asymmetry Branch Feedline”*

To:

Prof. Wen-Sheng Zhao

Associate Editor, IEEE Access

Re: Response to reviewers

Dear Editor,

Thank you for allowing the resubmission of our manuscript, with an opportunity to address the reviewers' comments.

We are uploading (a) our point-by-point response to the comments (below) (response to reviewers, under “Author’s Response Files”), (b) an updated manuscript with yellow highlighting indicating changes (as “Highlighted PDF”), and (c) a clean updated manuscript without highlights (“Main Manuscript”).

Best regards,

Syah Alam, et al.

Please address all correspondence to:

Syah Alam* / Zahriladha Zakaria**

*Department of Electrical Engineering, Universitas Trisakti, DKI Jakarta, 11440

** Faculty of Electronic and Computer Technology and Engineering, Universiti Teknikal Malaysia Melaka (UTeM), Malaysia

Corresponding author e-mail: [*syah.alam@trisakti.ac.id](mailto:syah.alam@trisakti.ac.id) / ** zahriladha@utem.edu.my

Reviewer#1

Concern # 1:

The explanation of the paper is good. However, I don't think the prototype described in the paper is a sensor. To me, it appears to be an antenna (single port) designed for multiband operations. Additionally, in Figure 6(c), it seems that the antenna incorporates a superstrate for gain enhancement applications.

Author response:

We thank the reviewer for constructive comments. We agree with the reviewer's comment that the proposed resonator can also function as an antenna due to its single port configuration. However, based on the simulation results, the proposed resonator has low performance as an antenna as shown in Fig. 1 (a) and Fig. 1 (b).

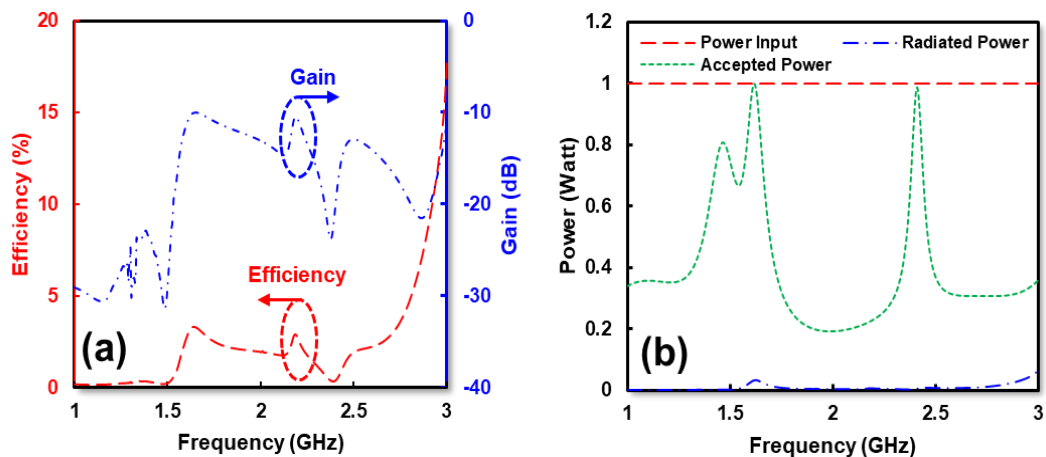

Fig. 1 Simulation result of single port resonator, (a) efficiency and gain of proposed resonator, (b) comparison between input, accepted dan transmitted power of proposed resonator

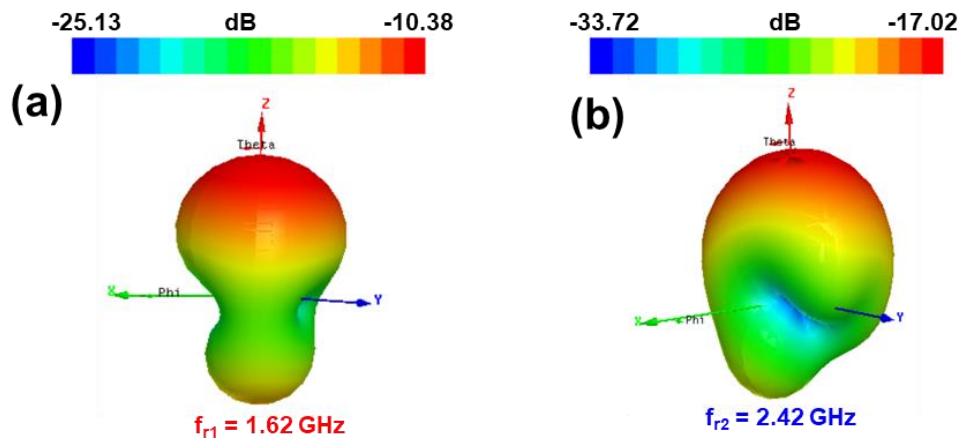

Fig. 2 Simulation result of radiation pattern, (a) radiation pattern at $f_{r1} = 1.62$ GHz, (b) radiation pattern at $f_{r2} = 2.42$ GHz

Fig. 1 (a) shows that the proposed resonator has low efficiency at $f_{r1} = 1.61$ GHz and $f_{r2} = 2.42$ GHz of 3.04% and 0.68%, respectively. In addition, the gain of proposed resonator is also very low where for $f_{r1} = 1.62$ GHz and $f_{r2} = 2.42$ GHz it is -10.37 dB and -16.63 dB, respectively. Furthermore, the ratio between the input power, received power and transmitted power of the proposed resonator is also very low as shown in **Fig. 1 (b)**. From the simulation results, the default input power is 1 watt while the transmitted power for $f_{r1} = 1.62$ GHz and $f_{r2} = 2.42$ GHz is 0.98 watt

and 0.97 watt. However, the transmitted power is very low where for $f_{r1} = 1.62$ GHz and $f_{r2} = 2.42$ GHz is 0.03 watt and 0.006 watt, respectively. Furthermore, the radiation pattern of the proposed resonator is shown in **Fig. 2 (a)** and **Fig. 2 (b)** where for $f_{r1} = 1.62$ GHz and $f_{r2} = 2.42$ GHz has a maximum gain of -10.38 dB and -17.02 dB. This finding indicates that the proposed resonator has low performance as an antenna due to low efficiency and gain. Since the performance of the proposed resonator is not functioning as an antenna, this structure is more suitable for microwave sensor.

In this work, the sensor is designed to detect the permittivity of the sample by observing the interaction between the electric field and the permittivity of the sample used. The resonator surface that has a high electric field (E-field) can be recommended as the sensing area used to place the sample. The sample used is a dielectric sample that does not contain metal.

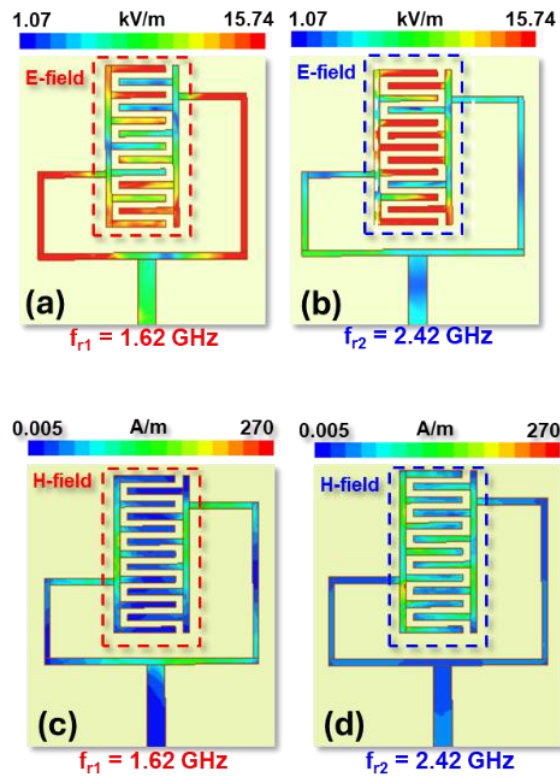

Fig.3. E-field and H-field simulations; (a) E-field at $f_{r1} = 1.62$ GHz, (b) E-field at $f_{r2} = 2.41$ GHz, (c) H-field at $f_{r1} = 1.62$ GHz, (d) H-field at $f_{r2} = 2.42$ GHz

Furthermore, the electric field and magnetic field concentrations of the IDC-based resonator are shown in **Fig.3 (a)**, **Fig.3 (b)**, **Fig.3 (c)** and **Fig.3 (d)**. Furthermore, **Fig. 3 (a)** and **Fig. 3 (b)** show that the highest electric field concentration of the proposed resonator at $f_{r1}=1.62$ GHz and $f_{r2}= 2.42$ GHz is on the IDC surface of the proposed sensor with a range of 1.07 – 15.74 kV/m. In contrast, the magnetic field concentration of the proposed resonator at $f_{r1}=1.62$ GHz and $f_{r2}= 2.42$ GHz are very low and is in the range of 0.005 – 270 A/m. These findings indicate that the IDC surface has a high electric field and a low magnetic field so that it becomes a potential location as a sensing area that can be recommended to place samples to be detected. It also shows that the application of the IDC structure has successfully confined the electric field and reduced the magnetic field in the proposed sensor. Therefore, we propose the single port resonator as a microwave sensor for permittivity detection of solid materials.

Author action: We updated the manuscript by adding simulation data of the gain, efficiency and radiation pattern of the proposed single port resonator which is represented by **Fig. 4** and **Fig. 5** in the revised paper.

Kindly refer to: Section II. WORKING PRINCIPLE OF PROPOSED SENSOR, Sub-section B. STRUCTURE OF PROPOSED IDC RESONATOR USING ASYMMETRY BRANCH FEED LINE, Fig.4 and Fig.5 page 3.

A. STRUCTURE OF PROPOSED IDC RESONATOR USING ASYMMETRY BRANCH FEED LINE

The proposed microwave sensor is designed using FR-4 substrate type with dielectric constant (ϵ_r) 4.3, loss tan ($\tan \alpha$) 0.0265 and thickness (h) 1.6 mm. The microwave sensor is designed using a single-port resonator operating at two different resonant frequencies $f_{r1} = 1.62$ GHz and $f_{r2} = 2.42$ GHz. To produce dual frequencies, the resonator is connected with RP-SMA connector with impedance of 50Ω using dual-feed approach.

In addition, to increase the electric field concentration of the resonator, interdigital capacitor (IDC) structure is proposed as a solution. Fig. 2 (a) shows the dimensions of the proposed sensor. Furthermore, Fig. 2 (b) shows the structure of the proposed sensor where the sensor is designed using a PCB with two copper layers while the upper layer of the PCB is used to place the sensor made of copper and the lower layer is used as a ground plane.

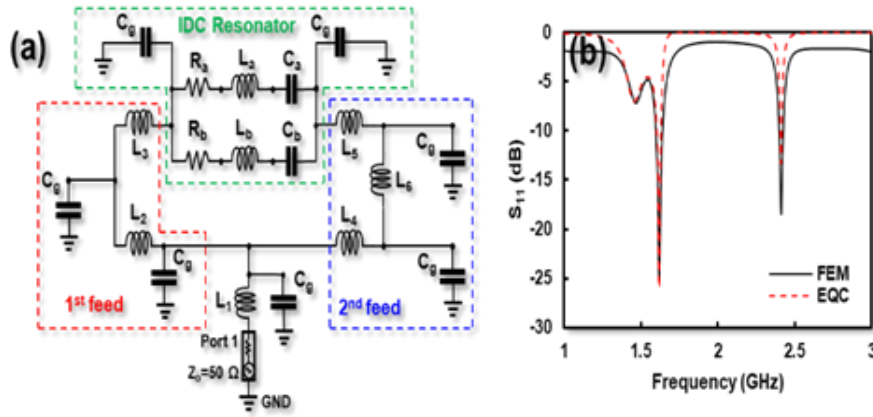

Fig.2. Modeling of the proposed sensor; (a) Equivalent circuit of the proposed sensor, (b) comparison of simulation results from FEM and EQC.

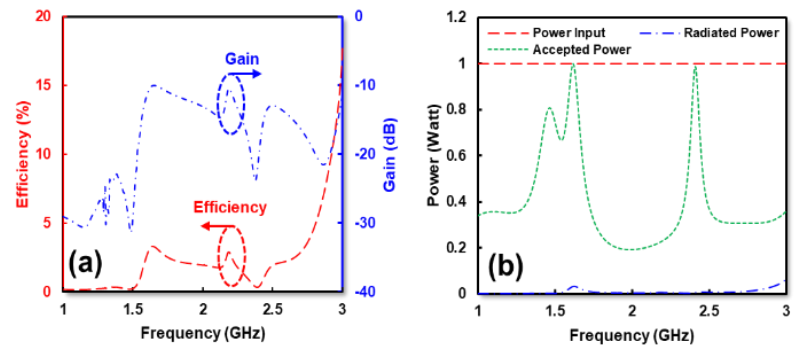

Fig. 3. Simulation result of single port resonator, (a) efficiency and gain of proposed resonator, (b) comparison between input, accepted dan transmitted power of proposed resonator

The simulation results of the proposed sensor are shown in Fig. 2 (c) where the sensor operates at two different resonant frequencies, namely $f_{r1} = 1.62$ GHz and $f_{r2} = 2.42$ GHz.

The dimensions of the proposed sensor are represented by $W_g = 50$ mm, $L_g = 50$ mm, $W_s = 3.1$ mm, $L_c = 15$ mm, $L_a = 17.3$ mm, $L_b = 15.9$ mm, $W_s = 1$ mm, $L_c = 26.7$ mm, $L_d = 13.7$ mm, $L_e = 11.8$ mm and $L_f = 11.8$ mm. Furthermore, the dimensions of the IDC structure are represented by $W_i = 11.7$ mm and $L_i = 25$ mm while the gaps in each IDC are represented by $G_i = G_s = 1$ mm. It should be noted that the width and length of the gap greatly affect the electric field concentration and the resonant frequency of the proposed sensor.

The performance in terms of gain and efficiency of the single port resonator are shown in Fig. 3(a) and Fig. 3(b). Furthermore, Fig. 3 (a) shows that the proposed resonator has low efficiency at $f_{r1} = 1.61$ GHz and $f_{r2} = 2.42$ GHz of 3.04% and 0.68%, respectively. In addition, the gain of proposed resonator is also very low where for $f_{r1} = 1.62$ GHz and $f_{r2} = 2.42$ GHz it is -10.37 dB and -16.63 dB, respectively. Furthermore, the ratio between the input power, received power and transmitted power of the proposed resonator is also very low as shown in Fig. 3 (b). From the simulation results, the default input power is 1 watt while the transmitted power for $f_{r1} = 1.62$ GHz and $f_{r2} = 2.42$ GHz is 0.98 watt and 0.97

watt. However, the transmitted power is very low where for $f_{r1} = 1.62$ GHz and $f_{r2} = 2.42$ GHz is 0.03

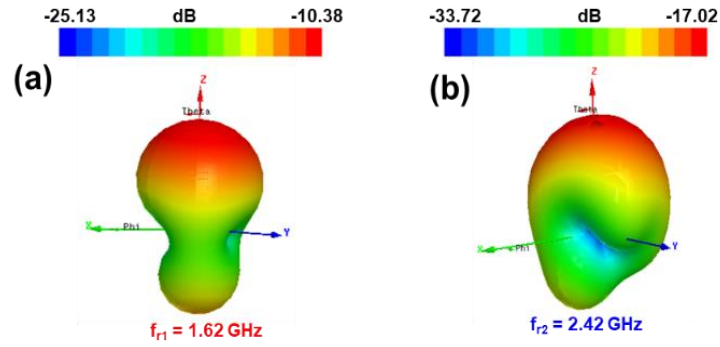

Fig. 4. Simulation result of radiation pattern, (a) radiation pattern at $f_{r1} = 1.62$ GHz, (b) radiation pattern at $f_{r2} = 2.42$ GHz

watt and 0.006 watt, respectively. Furthermore, the radiation pattern of the proposed resonator is shown in **Fig. 4 (a)** and **Fig. 4 (b)** where $f_{r1} = 1.62$ GHz and $f_{r2} = 2.42$ GHz have a maximum gain of -10.38 dB and -17.02 dB. This finding indicates that the proposed resonator has low performance as an antenna due to low efficiency and gain. This finding indicates that the proposed resonator has low performance to function as an antenna due to low efficiency and gain. Thus, this structure is more suitable for microwave sensors.

Reviewer#2

The characterization of solid material permittivity at dual frequencies using a dual-band resonator sensor, with improved stability and high performance, presented in this manuscript is intriguing. Therefore, I recommend considering the publication of this work in IEEE Access, with some suggested improvements.

Concern # 1:

Include expressions that help estimate the dual-band resonant frequencies using the proposed IDC resonator structure.

Author response:

We thank the reviewer for constructive comments. Next, to estimate the performance of the resonator having dual band characteristics, we propose a development model of the proposed resonator as shown in Fig. 4.

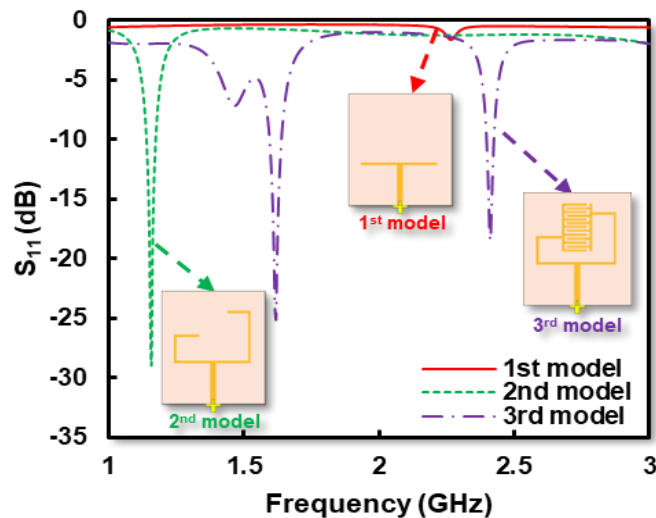

Fig.4. Development model of the proposed resonator, (a) 1st model, (b) 2nd model, (c) 3rd model

Fig.4 shows that the 1st model of the resonator is represented by a T-shaped resonator operating at a single band at a frequency of 2.26 GHz. Furthermore, the 2nd model is represented by a T-shaped connected with two open-ended inductive arms that function as branch lines that generate a single band resonant frequency of 1.16 GHz. The resonant frequency of the resonator moves to a lower frequency in line with the increase in the arm length of the resonator. In the third model, the IDC structure is connected with two open-ended inductive arms of the resonator that produce dual-band characteristics with $f_{r1} = 1.62$ GHz and $f_{r2} = 2.42$ GHz.

In addition, we have also presented the equivalent circuit of the resonator represented by R, L and C to demonstrate the dual band characteristics of the proposed resonator. The inductive arm is represented by the inductor (L) while the gap of the resonator is represented by the capacitor (C) and the resistor (R) represents the tan delta of the substrate. Overall, the resonant frequency of the resonator can be determined using the following equation:

$$f_r = \frac{1}{2\pi\sqrt{LC}} \quad (1)$$

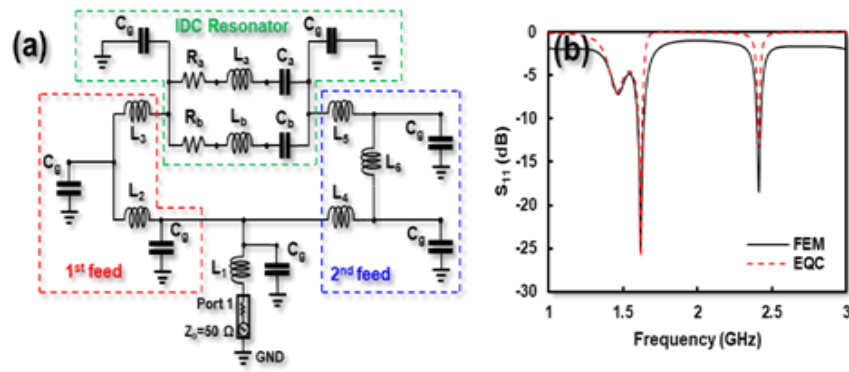

Fig 2. Modeling of the proposed sensor; (a) Equivalent circuit of the proposed sensor, (b) comparison of simulation results from FEM and EQC.

The proposed sensor can be modeled using an equivalent circuit (EQC) based on resistor (R), capacitor (C) and inductor (L) [26] as shown in **Fig. 2(a)**. The equivalent circuit of the proposed sensor is simulated using EM simulation and compared with Finite Element Modeling (FEM) as shown in **Fig. 2(b)**. Based on the equivalent circuit shown in **Fig. 2 (a)**, the feedline of the resonator is represented by $L_7 = 14$ nH which is connected to port 1 with an impedance of $Z_0 = 50\Omega$. In this work, the asymmetric branch feedline is represented by $L_2 = 15.3$ nH and $L_3 = 0.71$ nH as the 1st arm while the 2nd arm is represented by $L_4 = 0.000242$ nH, $L_5 = 20.89$ nH and $L_6 = 9.18$ nH. In addition, the IDC resonator is represented by two resonators with series configuration connected in parallel where $R_a = 0.027$ k Ω , $L_a = 41.97$ nH, $C_a = 805$ pF while for $R_b = 2.46$ k Ω , $L_b = 0.262$ nH and $C_b = 6.28$ pF. To prevent short circuits, $C_g = 1$ pF is proposed as grounding.

Author action: We updated the manuscript by adding sub-section **II.A. Development model of proposed resonator** and **Fig. 1** which represents the simulation results of the development model for the proposed resonator. We have also presented the equivalent circuit of the proposed resonator represented by **Fig. 3** in the revised paper.

Kindly refer to: Section II. WORKING PRINCIPLE OF PROPOSED SENSOR, Sub-section A. DEVELOPMENT MODEL OF PROPOSED RESONATOR, **Fig.1**, page 2 and **Fig. 3**, page 3.

A. DEVELOPMENT MODEL OF PROPOSED RESONATOR

Furthermore, to estimate the performance of the resonator having dual band characteristics, a development model of the proposed resonator was represented as shown in **Fig. 1**. The 1st model of the resonator is represented by a T-shaped resonator operating at a single band at a frequency of 2.26 GHz. Furthermore, the 2nd model is represented by a T-shaped connected with two open-ended inductive arms that function as branch lines that generate a single band resonant frequency of 1.16 GHz. The resonant frequency of the resonator moves to a lower frequency in line with the increase in

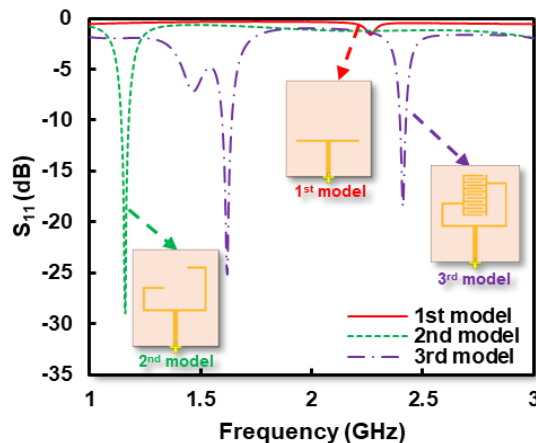

the arm length of the resonator. In the 3rd model, the IDC structure is connected with two open-ended inductive arms of the resonator that produce dual-band characteristics with $f_{r1} = 1.62$ GHz and $f_{r2} = 2.42$ GHz.

Fig. 1. Development model of proposed resonator, (a) 1st model, (b) 2nd model, (c) 3rd model

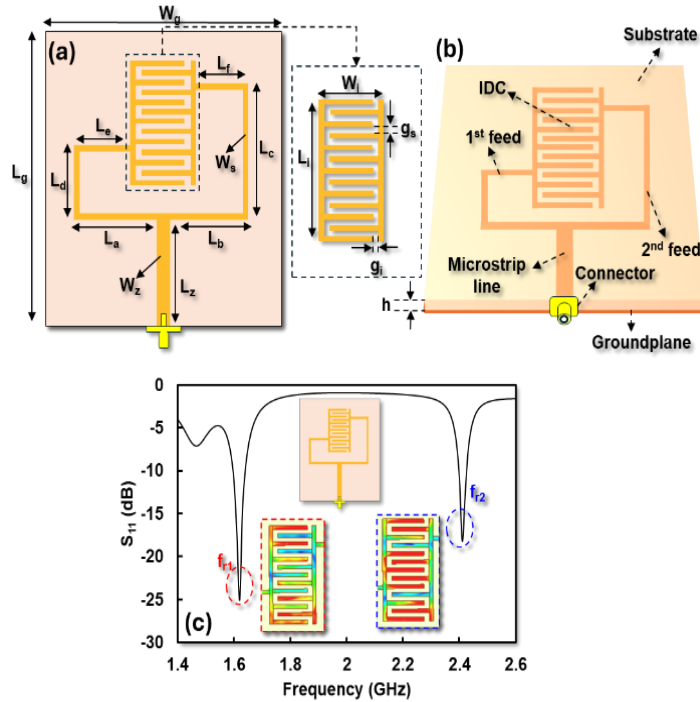

Fig. 2 Model of the microwave sensor; (a) dimensions of the microwave sensor, (b) structure of the microwave sensor, (c) simulation of the reflection coefficient of the microwave sensor

C. EQUIVALENT CIRCUIT MODEL OF PROPOSED RESONATOR

Next, the proposed sensor can be modeled using an equivalent circuit (EQC) based on resistor (R), capacitor (C) and inductor (L) [28] as shown in **Fig. 3 (a)**. The equivalent circuit of the proposed sensor is simulated using EM simulation and compared with Finite Element Modeling (FEM) as shown in **Fig. 3 (b)**. Based on the equivalent circuit shown in **Fig. 3 (a)**, the feedline of the resonator is represented by $L_1 = 14$ nH which is connected to port 1 with an impedance of $Z_0 = 50\Omega$. In this work, the asymmetric branch feedline is represented by $L_2 = 15.3$ nH and $L_3 = 0.71$ nH as the 1st arm while the 2nd arm is represented by $L_4 = 0.000242$ nH, $L_5 = 20.89$ nH and $L_6 = 9.18$ nH. In addition, the IDC resonator is represented by two resonators with series configuration connected in parallel where $R_a = 0.027$ k Ω , $L_a = 41.97$ nH, $C_a = 805$ pF while for $R_b = 2.46$ k Ω , $L_b = 0.262$ nH and $C_b = 6.28$ pF. To prevent short circuits, $C_g = 1$ pF is proposed as grounding. Overall, the resonant frequency of the resonator can be determined using the following equation:

$$f_r = \frac{1}{2\pi\sqrt{LC}} \quad (1)$$

Fig. 3 (b) shows that the simulation results of EQC and FEM have identical characteristics where the resonator operates in dual band with $f_{r1} = 1.62$ GHz and $f_{r2} = 2.42$ GHz. This finding indicates that the proposed equivalent circuit model has represented the working principle of the proposed resonator.

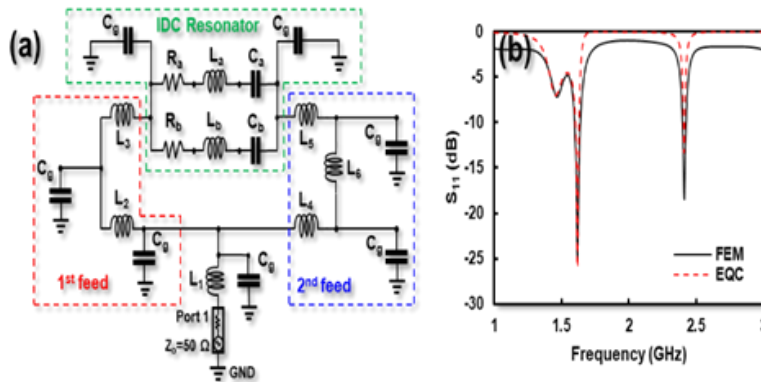

Fig. 3. Modeling of the proposed sensor; (a) Equivalent circuit of the proposed sensor, (b) comparison of simulation results from FEM and EQC.

Concern # 2:

How did you calculate the component values in the equivalent circuit?

Author response:

We thank the reviewer for constructive comments. In this paper, we calculate and optimize the values of R, L and C components using AWR 2009 to represent the resonant frequency of the proposed resonator. The inductive arm is represented by the inductor (L) while the gap of the resonator is represented by the capacitor (C) and the resistor (R) represents the tan delta of the substrate. Overall, the resonant frequency of the resonator can be determined using the following equation [1]:

$$f_r = \frac{1}{2\pi\sqrt{LC}} \quad (1)$$

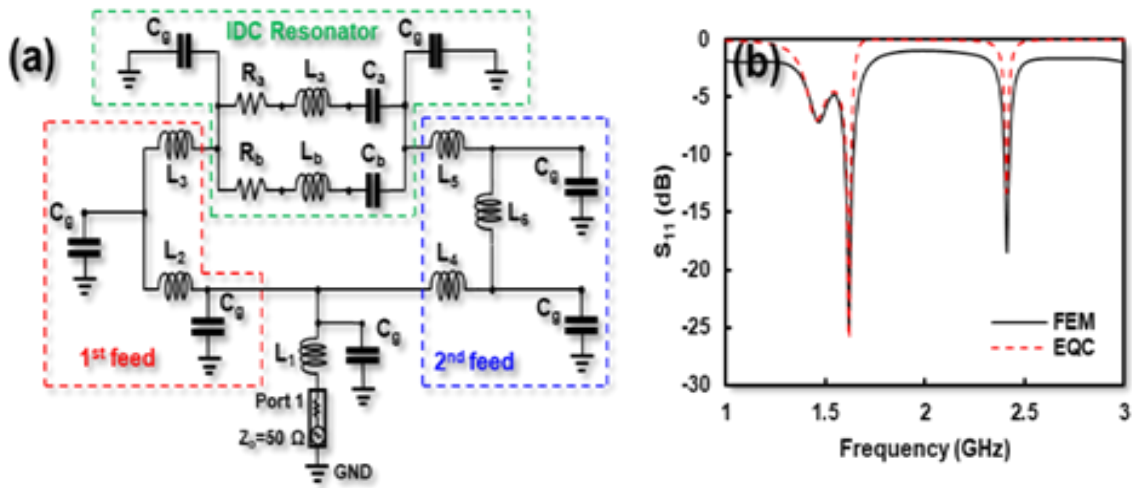

Fig 2. Modeling of the proposed sensor; (a) Equivalent circuit of the proposed sensor, (b) comparison of simulation results from FEM and EQC.

The proposed sensor can be modeled using an equivalent circuit (EQC) based on resistor (R), capacitor (C) and inductor (L) [26] as shown in Fig. 2(a). The equivalent circuit of the proposed sensor is simulated using EM simulation and compared with Finite Element Modeling (FEM) as shown in Fig. 2(b). Based on the equivalent circuit shown in Fig. 2 (a), the feedline of the resonator is represented by $L_1 = 14$ nH which is connected to port 1 with an impedance of $Z_0 = 50\Omega$. In this work, the asymmetric branch feedline is represented by $L_2 = 15.3$ nH and $L_3 = 0.71$ nH as the 1st arm while the 2nd arm is represented by $L_4 = 0.000242$ nH, $L_5 = 20.89$ nH and $L_6 = 9.18$ nH. In addition, the IDC resonator is represented by two resonators with series configuration connected in parallel where $R_a = 0.027$ k Ω , $L_a = 41.97$ nH, $C_a = 805$ pF while for $R_b = 2.46$ k Ω , $L_b = 0.262$ nH and $C_b = 6.28$ pF. To prevent short circuits, $C_g = 1$ pF is proposed as grounding.

Author action: We updated the manuscript by explaining the equivalent circuit of the proposed sensor

Kindly refer to: Section II. WORKING PRINCIPLE OF PROPOSED SENSOR, Sub-section C. EQUIVALENT CIRCUIT MODEL OF PROPOSED RESONATOR., Fig. 3, page 3.

C. EQUIVALENT CIRCUIT MODEL OF PROPOSED RESONATOR

Next, the proposed sensor can be modeled using an equivalent circuit (EQC) based on resistor (R), capacitor (C) and inductor (L) [28] as shown in **Fig. 3 (a)**. The equivalent circuit of the proposed sensor is calculated and simulated using AWR 2009 and compared with Finite Element Modeling (FEM) as shown in **Fig. 3 (b)**. Based on the equivalent circuit shown in **Fig. 3 (a)**, the feedline of the resonator is represented by $L_1 = 14$ nH which is connected to port 1 with an impedance of $Z_0 = 50\Omega$. In this work, the asymmetric branch feedline is represented by $L_2 = 15.3$ nH and $L_3 = 0.71$ nH as the 1st arm while the 2nd arm is represented by $L_4 = 0.000242$ nH, $L_5 = 20.89$ nH and $L_6 = 9.18$ nH. In addition, the IDC resonator is represented by two resonators with series configuration connected in parallel where $R_a = 0.027$ k Ω , $L_a = 41.97$ nH, $C_a = 805$ pF while for $R_b = 2.46$ k Ω , $L_b = 0.262$ nH and $C_b = 6.28$ pF. To prevent short circuits, $C_g = 1$ pF is proposed as grounding. Overall, the resonant frequency of the resonator can be determined using the following equation[1]:

$$f_r = \frac{1}{2\pi\sqrt{LC}} \quad (1)$$

Fig. 3 (b) shows that the simulation results of EQC and FEM have identical characteristics where the resonator operates in dual band with $f_{r1} = 1.62$ GHz and $f_{r2} = 2.42$ GHz. This finding indicates that the proposed equivalent circuit model has represented the working principle of the proposed resonator.

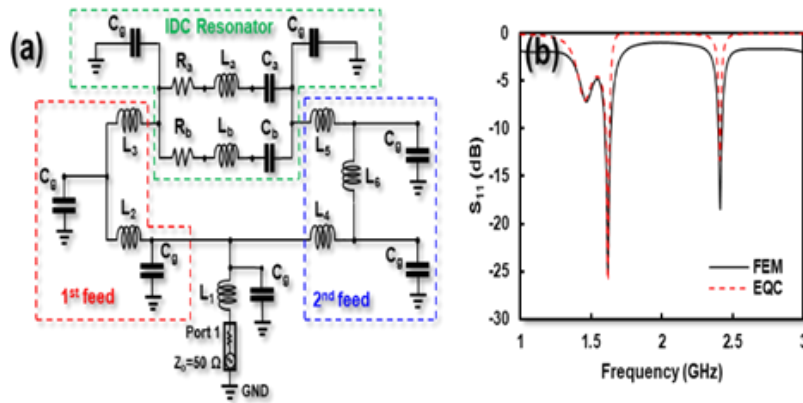

Fig 3. Modeling of the proposed sensor; (a) Equivalent circuit of the proposed sensor, (b) comparison of simulation results from FEM and EQC.

Reference:

- [1] S. Alam, Z. Zakaria, I. Surjati, N. A. Shairi, M. Alaydrus, and T. Firmansyah, "Multifunctional of dual-band permittivity sensors with antenna using multicascoded T-shaped resonators for simultaneous measurement of solid materials and data transfer capabilities," *Meas. J. Int. Meas. Confed.*, vol. 217, no. November 2022, p. 113078, 2023, doi: 10.1016/j.measurement.2023.113078.

Concern # 3:

Please consider adding the following relevant works in the literature review of the introduction and comparison table.

- “High-Accuracy Complex Permittivity Characterization of Solid Materials Using Parallel Interdigital Capacitor- Based Planar Microwave Sensor.” 10.1109/JSEN.2020.3041014
- “Design and Optimization of Interdigitated Microwave Sensor for Multidimensional Sensitive Characterization of Solid Materials.” 10.1109/JSEN.2021.3105410

Author response:

We thank the reviewer for constructive comments. We have included the following references in the literature review and comparison Table III.

Author action: We updated the manuscript by including the following references in the literature review and comparison table III

Kindly refer to: Section I. INTRODUCTION, page 1 and Table III. COMPARISON WITH PREVIOUS WORKS, page 9.

Microwave sensors (MS) have seen significant advancement in the evaluation of both solids and liquids due to their advantages, such as high precision, a high Q-factor, cost-effectiveness, and compactness [1]–[3]. One of the measurable properties using MS is permittivity, which reflects a material's ability to sustain an electric field. The permittivity of the material under test (MUT) can be determined via perturbation theory, assuming the MUT behaves as a capacitive load [4]–[6]. Several microwave sensors based on resonators like the Split Ring Resonator (SRR) [7]–[10], Complementary Split Ring Resonator (CSRR)[11]–[13], Substrate Integrated Waveguide (SIW) [14],[15], Interdigital Capacitor (IDC) [16]–[20], AMC [21],[22] have been developed for solid and liquid material assessment.

Previous work presented a single-port MS based on slot loaded [23] and dual U-shaped [24] for solid material characterization. Furthermore, another work proposed a dual-function permittivity sensor with an antenna using a single-port resonator for solid material characterization using an aperture coupling structure [25]. In addition, previous work [26] proposed a single-port microwave sensor based on dual T-shaped for contact and long-distance detection. The advantage of a single-port resonator-based microwave sensor is that it can also function as an antenna for data transmission[27].

TABLE III
COMPARISON WITH PREVIOUS WORKS

Ref.	Method	Freq (GHz)	Range of ϵ_r	Performance			Num. of port	Dual-band performance	Confined E-field region	Disturbance analysis effect	High stability performance
				Max. FDR (GHz)	Max NS. (%)	Max Acc. (GHz)					
[8]	SRR	0.39	1 – 7.33	0.102	1.625	98.20	1	-	Yes	-	-
[10]	SSRR with spurlines	2.22	1 – 4.40	0.030	1.340	98.36	2	-	Yes	-	-
[13]	CSRR	2.65	1 – 3.00	0.150	5.380	97.71	2	-	Yes	-	-
[19]	IDC	2.65	1 – 6.15	0.373	4.300	99.99	2	-	Yes	-	-
[20]	IDC	2.35 / 5.79	1 – 10.5	0.150	3.980	99.99	2	-	Yes	-	-
[21]	Artificial Magnetic Conductor	4.04	1 – 4.40	0.070	1.890	96.48	1	-	Yes	-	-
[23]	Slot-loaded patch	2.50	1 – 10.20	0.072	5.240	98.80	1	-	-	-	-
[24]	Dual U-shaped	1.20 / 2.10	1 – 4.30	0.007	1.150	99.02	1	Yes	Yes	-	-
[25]	Aperture coupling	9.54 / 12.30	1 – 12.50	0.078	0.640	92.30	1	Yes	Yes	-	-
[26]	Dual T-shaped with IDC	1.64 / 2.43	1 – 6.15	0.016	0.003	95.99	1	Yes	Yes	-	-
[32]	SRR	1.24 / 2.08	1 – 6.00	0.050	4.101	96.97	2	Yes	Yes	-	-
This work	Asymmetric branch feed with IDC	1.61 / 2.52	1 – 6.15	0.110	4.330	95.98	1	Yes	Yes	Yes	Yes

A thorough evaluation comparing the proposed sensor's performance with previous studies is conducted, as detailed in **Table III**. A fair comparison with previous work is proposed by observing the performance of the sensor in terms of the method, permittivity range, resonance frequency (f_r), Frequency Detection Resolution (FDR), Normalized Sensitivity (NS) and accuracy. In addition, other performances that are compared are dual band characteristics, e-field localization, disturbance effect analysis and also high stability of the proposed sensor.

Previous work proposed a microwave sensor using a dual-port resonator for permittivity detection of solid materials based on SRR [8],[10],[32], IDC structure [19],[20] and CSRR[13]. The sensor has good performance with a maximum accuracy of 96% - 98% and a normalized sensitivity of 1.34% - 5.38%. However, the proposed sensor only supports transmission mode-based measurements and requires a two-port network analyzer for characterization, which can increase the complexity and cost of the measurement setup.

Previous studies introduced a single-port resonator incorporating a slot for permittivity detection of dielectric samples, achieving an accuracy of 98.80% and a normalized sensitivity of 5.24% [23]. However, the sensor's electric field remains inadequately localized and focused on the sensing area, potentially leading to measurement inaccuracies in the presence of interference or disturbances. In addition, the proposed sensor only operates at a single resonant frequency. Moreover, a single-port microwave sensor with dual band performance utilizing U-shaped [24] and T-shaped resonators [26] was proposed in another study, featuring independent characteristics for simultaneous detection of solid material permittivity and long-distance sensing. The electric field of the resonator was localized on its arm, designated as the sensing area. However, the study did not include an analysis of disturbance effects, leaving the stability of the proposed sensor under disturbed conditions unverified.

Previous work introduced a single-port microwave sensor employing aperture coupling [25] and an artificial magnetic conductor [21]. The electric field was localized on a separate substrate, designated as the sensor's sensing area. However, the proposed structure features a multilayer design, making it more complex to implement. Furthermore, the study did not include an analysis of disturbance effects, leaving the sensor's stability under such conditions unverified. This work provides an excellent solution to produce a microwave sensor using a single-port resonator that has high stability against disturbances. In this work, an interdigital capacitor structure is introduced to confine the E-field of the sensor to focus it on the sensing area of the sensor. In addition, the interdigital capacitor structure also reduces the H-field so that the E-field becomes more dominant. The stability of the sensor is evaluated and confirmed by placing a disturbance in the form of a rectangular copper shield placed directly above the sensor. The performance and stability of the sensor are observed in conditions without and with copper shielding for a distance range of $d = 1 \text{ cm} - 2.5 \text{ cm}$. From the measurement results, the sensor has high stability both without and with disturbance with a Frequency Detection Resolution (FDR) of 0.009 - 0.4 GHz/ $\Delta\epsilon_r$, a Normalized Sensitivity (NS) of 0.4% - 4.4%, and an average accuracy of 90% - 95% for both resonance frequencies, respectively.

Reference:

- [1] K. S. L. Parvathi and S. R. Gupta, "Ultrahigh-Sensitivity and Compact EBG-Based Microwave Sensor for Liquid Characterization," *IEEE Sensors Lett.*, vol. 6, no. 4, pp. 19–22, 2022, doi: 10.1109/LSENS.2022.3159800.
- [2] A. Armghan, T. M. Alanazi, A. Altaf, and T. Haq, "Characterization of Dielectric Substrates Using Dual Band Microwave Sensor," *IEEE Access*, vol. 9, pp. 62779–62787, 2021, doi: 10.1109/ACCESS.2021.3075246.
- [3] Z. Shaterian and M. Mrozowski, "Multifunctional Bandpass Filter/Displacement Sensor Component," *IEEE Access*, vol. 11, no. March, pp. 27012–27019, 2023, doi: 10.1109/ACCESS.2023.3258545.
- [4] A. Aquino, C. G. Juan, B. Potelon, and C. Quendo, "Dielectric Permittivity Sensor Based on Planar Open-Loop Resonator," *IEEE Sensors Lett.*, vol. 5, no. 3, pp. 2021–2024, 2021, doi: 10.1109/LSENS.2021.3055544.
- [5] W. A. Jabbar *et al.*, "Design and Fabrication of Smart Home with Internet of Things Enabled Automation System," *IEEE Access*, vol. 7, pp. 144059–144074, 2019, doi: 10.1109/ACCESS.2019.2942846.
- [6] A. Ebrahimi, J. Scott, and K. Ghorbani, "Ultrahigh-Sensitivity Microwave Sensor for Microfluidic Complex Permittivity Measurement," *IEEE Trans. Microw. Theory Tech.*, vol. 67, no. 10, pp. 4269–4277, 2019, doi: 10.1109/TMTT.2019.2932737.
- [7] P. Jahangiri, M. Naser-Moghadasi, B. Ghalamkari, and M. Dousti, "A new planar microwave sensor for fat-measuring of meat based on SRR and periodic EBG structures," *Sensors Actuators A Phys.*, vol. 346, no. June, p. 113826, 2022, doi: 10.1016/j.sna.2022.113826.
- [8] K. Xu *et al.*, "Novel Microwave Sensors Based on Split Ring Resonators for Measuring Permittivity," *IEEE Access*, vol. 6, pp. 26111–26120, 2018, doi: 10.1109/ACCESS.2018.2834726.
- [9] W. Liu, J. Zhang, and K. Huang, "Dual-Band Microwave Sensor Based on Planar Rectangular Cavity Loaded with Pairs of Improved Resonator for Differential Sensing Applications," *IEEE Trans. Instrum. Meas.*, vol. 70, 2021, doi: 10.1109/TIM.2021.3118090.
- [10] R. A. Alahnomi, Z. Zakaria, E. Ruslan, S. R. Ab Rashid, and A. A. Mohd Bahar, "High-Q sensor based on symmetrical split ring resonator with spurlines for solids material detection," *IEEE Sens. J.*, vol. 17, no. 9, pp. 2766–2775, 2017, doi: 10.1109/JSEN.2017.2682266.
- [11] M. Saadat-Safa, V. Nayyeri, M. Khanjarian, M. Soleimani, and O. M. Ramahi, "A CSRR-Based Sensor for Full Characterization of Magneto-Dielectric Materials," *IEEE Trans. Microw. Theory Tech.*, vol. 67, no. 2, pp. 806–814, 2019, doi: 10.1109/TMTT.2018.2882826.
- [12] M. Abdolrazzagh, N. Kazemi, V. Nayyeri, and F. Martin, "AI-Assisted Ultra-High-Sensitivity/Resolution Active-Coupled CSRR-Based Sensor with Embedded Selectivity," *Sensors*, vol. 23, no. 13, pp. 1–20, 2023, doi: 10.3390/s23136236.
- [13] M. A. H. Ansari, A. K. Jha, and M. J. Akhtar, "Design and Application of the CSRR-Based Planar Sensor for Noninvasive Measurement of Complex Permittivity," *IEEE Sens. J.*, vol. 15, no. 12, pp. 7181–7189, 2015, doi: 10.1109/JSEN.2015.2469683.
- [14] A. A. Mohd Bahar, Z. Zakaria, M. K. Md Arshad, R. A. Alahnomi, A. I. Abu-Khadrah, and W. Y. Sam, "Microfluidic biochemical sensor based on circular SIW-DMS approach for dielectric characterization application," *Int. J. RF Microw. Comput. Eng.*, vol. 29, no. 9, pp. 1–13, 2019, doi: 10.1002/mmce.21801.
- [15] A. A. Mohd Bahar, Z. Zakaria, M. K. Md. Arshad, A. A. M. Isa, Y. Dasril, and R. A. Alahnomi, "Real Time Microwave Biochemical Sensor Based on Circular SIW Approach for Aqueous Dielectric Detection," *Sci. Rep.*, vol. 9, no. 1, pp. 1–12, 2019, doi: 10.1038/s41598-019-41702-3.
- [16] J. Yeo and J. I. Lee, "High-sensitivity microwave sensor based on an interdigital-capacitor-shaped defected ground structure for permittivity characterization," *Sensors (Switzerland)*, vol. 19, no. 3, 2019, doi: 10.3390/s19030498.
- [17] S. Aiswarya, S. K. Menon, M. Donelli, and L. Meenu, "Development of a microwave sensor for solid and liquid substances based on closed loop

- resonator,” *Sensors*, vol. 21, no. 24, pp. 1–34, 2021, doi: 10.3390/s21248506.
- [18] L. Ali *et al.*, “Design and optimization of microwave sensor for the non-contact measurement of pure dielectric materials,” *Electron.*, vol. 10, no. 24, 2021, doi: 10.3390/electronics10243057.
- [19] L. Ali *et al.*, “Design and Optimization of Interdigitated Microwave Sensor for Multidimensional Sensitive Characterization of Solid Materials,” *IEEE Sens. J.*, vol. 21, no. 20, pp. 22814–22822, 2021, doi: 10.1109/JSEN.2021.3105410.
- [20] C. Wang *et al.*, “High-Accuracy Complex Permittivity Characterization of Solid Materials Using Parallel Interdigital Capacitor-Based Planar Microwave Sensor,” *IEEE Sens. J.*, vol. 21, no. 5, pp. 6083–6093, 2021, doi: 10.1109/JSEN.2020.3041014.
- [21] W. J. Wu and G. Wang, “A modified AMC-based antenna sensor for contactless measurement of complex permittivity,” *Meas. J. Int. Meas. Confed.*, vol. 206, no. June 2022, p. 112261, 2023, doi: 10.1016/j.measurement.2022.112261.
- [22] Q. Shi, X. W. Xuan, H. K. Nie, Z. Y. Wang, and W. Wang, “Antenna Sensor Based on AMC Array for Contactless Detection of Water and Ethanol in Oil,” *IEEE Sens. J.*, vol. 21, no. 19, pp. 21503–21510, 2021, doi: 10.1109/JSEN.2021.3102294.
- [23] J. Yeo and J. I. Lee, “Slot-loaded microstrip patch sensor antenna for high-sensitivity permittivity characterization,” *Electron.*, vol. 8, no. 5, 2019, doi: 10.3390/electronics8050502.
- [24] S. Alam, Z. Zakaria, I. Surjati, N. A. Shairi, M. Alaydrus, and T. Firmansyah, “Dual-Band Independent Permittivity Sensor Using Single-Port with a Pair of U-Shaped Structures for Solid Material Detection,” *IEEE Sens. J.*, vol. 22, no. 16, pp. 16111–16119, 2022, doi: 10.1109/JSEN.2022.3191345.
- [25] M. Behdani, M. M. H. Kalateh, H. Saghlatoon, J. Melzer, and R. Mirzavand, “High-Resolution Dielectric Constant Measurement Using a Sensor Antenna with an Allocated Link for Data Transmission,” *IEEE Sens. J.*, vol. 20, no. 24, pp. 14827–14835, 2020, doi: 10.1109/JSEN.2020.3012055.
- [26] S. Alam *et al.*, “Collaboratively Far-Field and Near-Field Regions for Dual-Modalities Microwave Permittivity Sensor Using T-Shaped Resonator Embedded With IDC,” *IEEE Sensors Lett.*, vol. 8, no. 7, pp. 8–11, 2024, doi: 10.1109/LSENS.2024.3415362.
- [27] S. Alam, Z. Zakaria, I. Surjati, N. A. Shairi, M. Alaydrus, and T. Firmansyah, “Multifunctional of dual-band permittivity sensors with antenna using multicascode T-shaped resonators for simultaneous measurement of solid materials and data transfer capabilities,” *Meas. J. Int. Meas. Confed.*, vol. 217, no. November 2022, p. 113078, 2023, doi: 10.1016/j.measurement.2023.113078.
-

High Stability Single-Port Dual Band Microwave Sensor Based on Interdigital Capacitor Structure with Asymmetry Branch Feedline

Syah Alam¹, (Member IEEE), Indra Surjati¹, (Member IEEE), Lydia Sari¹, (Member IEEE), R. Deiny Mardian¹, (Member IEEE), Teguh Firmansyah², (Member IEEE), Muhammad Iqbal³, Slamet Widodo⁴, Mudrik Alaydrus⁵, (Senior Member IEEE), Zahriladha Zakaria⁶, (Senior Member IEEE)

¹Department of Electrical Engineering, Universitas Trisakti, West Jakarta, Indonesia

²Department of Electrical Engineering, Universitas Sultan Ageng Tirtayasa, Kota Serang, Banten 42124, Indonesia

³Advanced Functional Materials Laboratory, Faculty of Industrial Technology, Institut Teknologi Bandung, Bandung 40132, Indonesia.

⁴Department of Mechanical and Biosystem Engineering, IPB University, Bogor 16680, Indonesia.

⁵Department of Electrical Engineering, Universitas Mercu Buana, West Jakarta, Indonesia

⁶Faculty of Electronic and Computer Technology and Engineering, Universiti Teknikal Malaysia Melaka (UTeM), Malaysia

Corresponding author: Syah Alam (e-mail: syah.alam@trisakti.ac.id) / Zahriladha Zakaria (zahriladha@utem.edu.my)

ABSTRACT This paper proposes a single-port interdigital capacitor (IDC) resonator based on asymmetric branch feed line with high stability performance for permittivity detection of solid materials with a permittivity range of 1 - 6.15. The microwave sensor is designed using a single-port resonator operating at two different resonant frequencies $f_{r1} = 1.61$ GHz and $f_{r2} = 2.52$ GHz. Dual band frequency was proposed using asymmetric branch feed line. In addition, to confine the electric field concentration of the resonator, an interdigital capacitor (IDC) structure is proposed as a solution. Furthermore, a copper shield was proposed as conducting material to evaluate performance stability of the sensor from disturbance effect with range of $d = 1$ cm - 2.5 cm. Based on the measurement results, the sensor has high stability both without and with disturbance with an a Frequency Detection Resolution (FDR) of 0.009 - 0.4 GHz/ $\Delta\epsilon_r$, a Normalized Sensitivity (NS) of 0.4% - 4.4%, and an average accuracy of 90% - 95% for both resonance frequencies, respectively. Therefore, this sensor can be recommended for several applications such as biomedical industry, pharmaceuticals and material quality control especially for outdoor measurements that are potentially affected by electromagnetic interference and disturbance.

INDEX TERMS Dual-band, high stability, interdigital capacitor, microwave sensor, single-port resonator

I. INTRODUCTION

Microwave sensors (MS) have seen significant advancement in the evaluation of both solids and liquids due to their advantages, such as high precision, a high Q-factor, cost-effectiveness, and compactness [1]–[3]. One of the measurable properties using MS is permittivity, which reflects a material's ability to sustain an electric field. The permittivity of the material under test (MUT) can be determined via perturbation theory, assuming the MUT behaves as a capacitive load [4]–[6]. Several microwave sensors based on resonators like the Split Ring Resonator (SRR) [7]–[10], Complementary Split Ring Resonator (CSRR)[11]–[13], Substrate Integrated Waveguide (SIW) [14],[15], Interdigital Capacitor (IDC) [16]–[20], AMC

[21],[22] have been developed for solid and liquid material assessment.

Previous work presented a single-port MS based on slot loaded [23] and dual U-shaped [24] for solid material characterization. Furthermore, another work proposed a dual-function permittivity sensor with an antenna using a single-port resonator for solid material characterization using an aperture coupling structure [25]. In addition, previous work [26] proposed a single-port microwave sensor based on dual T-shaped for contact and long-distance detection. The advantage of a single-port resonator-based microwave sensor is that it can also function as an antenna for data transmission[27]. However, the performance of a

single-port resonator-based microwave sensor has a high potential to be inferred by electromagnetic waves and is also susceptible to disturbance. This is because the single-port resonator also transmits electromagnetic waves so that it is more susceptible to environmental disturbances, for example conducting materials. In addition, another limitation is that there is a higher likelihood of interference between the input and reflected signals. This can lead to difficulties and instability in the accuracy of representing measurement data. Therefore, a single-port resonator-based microwave sensor with high stability is needed to obtain accurate and reliable measurement results.

This work provides an excellent solution by proposing a high stability single-port MS based on Interdigital Capacitor (IDC) structure. The MS is designed to operate at two different frequencies $f_{r1} = 1.61$ GHz and $f_{r2} = 2.52$ GHz using an asymmetric branch feed line while the IDC structure is used to confine the concentration of the E-field in the sensing area so that the sensor is more focused on detecting samples. Furthermore, to observe the performance stability of the proposed sensor, a rectangular copper shield as conducting material is placed right above the sensor surface with a distance range of $d = 1$ cm - 2.5 cm to emulate as a disturbance. The performance of the sensor observed in this work is related to frequency shift, ΔF , Frequency Detection Resolution (FDR), Normalized Sensitivity (NS) and average accuracy. In addition, an interdigital capacitor structure also can minimize the H-field distribution so that the highest E-field concentration is focused on the sensing area of the proposed sensor. From the measurement results, the proposed sensor has high stability both without and with disturbance for a distance range of $d = 1 - 2.5$ cm. The sensor has stable performance with a frequency detection resolution of 0.009 - 0.4 GHz/ $\Delta\epsilon_r$, a normalized sensitivity of 0.4% - 4.4%, and an average accuracy of 90% - 95% for both resonance frequencies, respectively.

II. WORKING PRINCIPLE OF PROPOSED SENSOR

This section explains the structure, equivalent circuit and sensing area location determination of the IDC resonator using asymmetric branch feedline.

A. DEVELOPMENT MODEL OF PROPOSED RESONATOR

Furthermore, to estimate the performance of the resonator having dual band characteristics, a development model of the proposed resonator was represented as shown in Fig. 1. The 1st model of the resonator is represented by a T-shaped resonator operating at a single band at a frequency of 2.26 GHz. Furthermore, the 2nd model is represented by a T-shaped connected with two open-ended inductive arms that function as branch lines that generate a single band resonant frequency of 1.16 GHz. The resonant frequency of the resonator moves to a lower frequency in line with the increase in the arm length of the resonator. In the 3rd model,

the IDC structure is connected with two open-ended inductive arms of the resonator that produce dual-band characteristics with $f_{r1} = 1.62$ GHz and $f_{r2} = 2.42$ GHz.

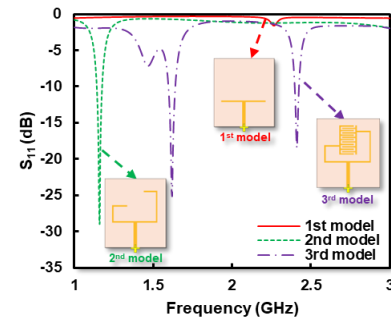

FIGURE 1. Development model of proposed resonator, (a) 1st model, (b) 2nd model, (c) 3rd model

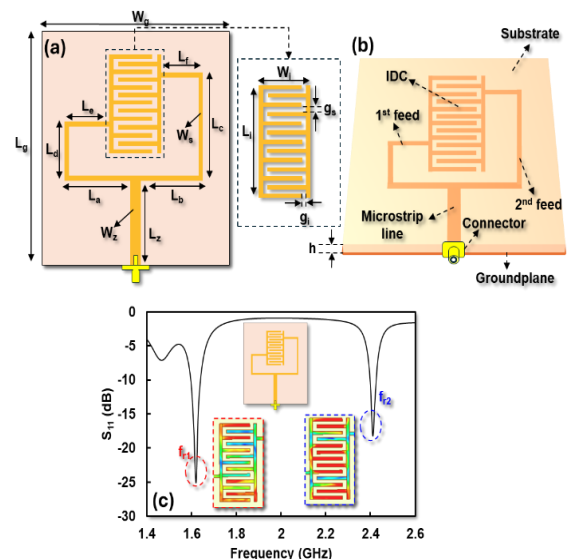

FIGURE 2. Model of the microwave sensor; (a) dimensions of the microwave sensor, (b) structure of the microwave sensor, (c) simulation of the reflection coefficient of the microwave sensor.

B. STRUCTURE OF PROPOSED IDC RESONATOR USING ASYMMETRY BRANCH FEED LINE

The proposed microwave sensor is designed using FR-4 substrate type with dielectric constant (ϵ_r) 4.3, loss tan ($\tan \alpha$) 0.0265 and thickness (h) 1.6 mm. The microwave sensor is designed using a single-port resonator operating at two different resonant frequencies $f_{r1} = 1.62$ GHz and $f_{r2} = 2.42$ GHz. To produce dual frequencies, the resonator is connected with RP-SMA connector with impedance of 50 Ω using dual-feed approach.

In addition, to increase the electric field concentration of the resonator, interdigital capacitor (IDC) structure is proposed as a solution. Fig. 2 (a) shows the dimensions of the proposed sensor. Furthermore, Fig. 2 (b) shows the structure of the proposed sensor where the sensor is designed using a PCB with two copper layers while the upper layer of the PCB is used to place the sensor made of copper and the

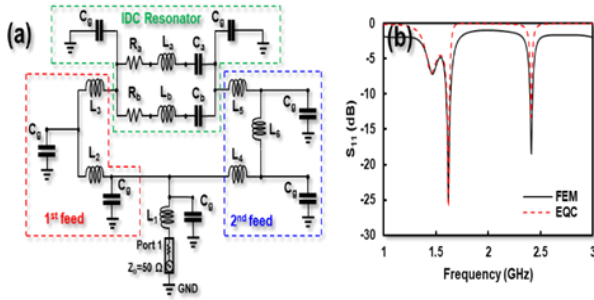

FIGURE 3. Modeling of the proposed sensor; (a) Equivalent circuit of the proposed sensor, (b) comparison of simulation results from FEM and EQC.

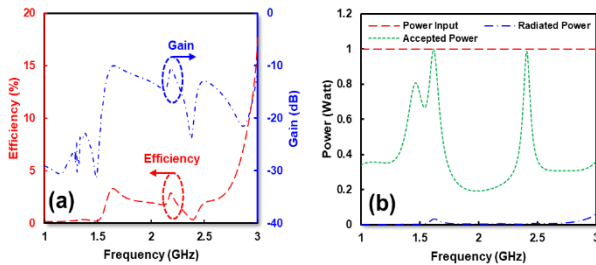

FIGURE 4. Simulation result of single port resonator, (a) efficiency and gain of proposed resonator, (b) comparison between input, accepted dan transmitted power of proposed resonator

lower layer is used as a ground plane. The simulation results of the proposed sensor are shown in **Fig. 2 (c)** where the sensor operates at two different resonant frequencies, namely $f_{r1} = 1.62$ GHz and $f_{r2} = 2.42$ GHz.

The dimensions of the proposed sensor are represented by $W_g = 50$ mm, $L_g = 50$ mm, $W_s = 3.1$ mm, $L_z = 15$ mm, $L_a = 17.3$ mm, $L_b = 15.9$ mm, $W_s = 1$ mm, $L_c = 26.7$ mm, $L_d = 13.7$ mm, $L_e = 11.8$ mm and $L_f = 11.8$ mm. Furthermore, the dimensions of the IDC structure are represented by $W_i = 11.7$ mm and $L_i = 25$ mm while the gaps in each IDC are represented by $G_i = G_s = 1$ mm. It should be noted that the width and length of the gap greatly affect the electric field concentration and the resonant frequency of the proposed sensor.

The performance in terms of gain and efficiency of the single port resonator are shown in **Fig. 4(a)** and **Fig. 4(b)**. Furthermore, **Fig. 4 (a)** shows that the proposed resonator has low efficiency at $f_{r1} = 1.61$ GHz and $f_{r2} = 2.42$ GHz of 3.04% and 0.68%, respectively. In addition, the gain of proposed resonator is also very low where for $f_{r1} = 1.62$ GHz and $f_{r2} = 2.42$ GHz it is -10.37 dB and -16.63 dB, respectively. Furthermore, the ratio between the input power, received power and transmitted power of the proposed resonator is also very low as shown in **Fig. 4 (b)**. From the simulation results, the default input power is 1 watt while the transmitted power for $f_{r1} = 1.62$ GHz and $f_{r2} = 2.42$ GHz is 0.98 watt and 0.97 watt. However, the transmitted power is very low where for $f_{r1} = 1.62$ GHz and $f_{r2} = 2.42$ GHz is 0.03

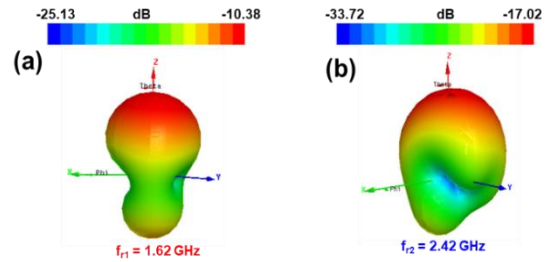

FIGURE 5. Simulation result of radiation pattern, (a) radiation pattern at $f_{r1} = 1.62$ GHz, (b) radiation pattern at $f_{r2} = 2.42$ GHz

watt and 0.006 watt, respectively. Furthermore, the radiation pattern of the proposed resonator is shown in **Fig. 5 (a)** and **Fig. 5 (b)** where $f_{r1} = 1.62$ GHz and $f_{r2} = 2.42$ GHz have a maximum gain of -10.38 dB and -17.02 dB. This finding indicates that the proposed resonator has low performance to function as an antenna due to low efficiency and gain. Thus, this structure is more suitable for microwave sensors.

C. EQUIVALENT CIRCUIT MODEL OF PROPOSED RESONATOR

Next, the proposed sensor can be modeled using an equivalent circuit (EQC) based on resistor (R), capacitor (C) and inductor (L) [28] as shown in **Fig. 3 (a)**. The equivalent circuit of the proposed sensor is calculated and simulated using AWR 2009 and compared with Finite Element Modeling (FEM) as shown in **Fig. 3 (b)**. Based on the equivalent circuit shown in **Fig. 3 (a)**, the feedline of the resonator is represented by $L_1 = 14$ nH which is connected to port 1 with an impedance of $Z_0 = 50\Omega$. In this work, the asymmetric branch feedline is represented by $L_2 = 15.3$ nH and $L_3 = 0.71$ nH as the 1st arm while the 2nd arm is represented by $L_4 = 0.000242$ nH, $L_5 = 20.89$ nH and $L_6 = 9.18$ nH. In addition, the IDC resonator is represented by two resonators with series configuration connected in parallel where $R_a = 0.027$ k Ω , $L_a = 41.97$ nH, $C_a = 805$ pF while for $R_b = 2.46$ k Ω , $L_b = 0.262$ nH and $C_b = 6.28$ pF. To prevent short circuits, $C_g = 1$ pF is proposed as grounding. Overall, the resonant frequency of the resonator can be determined using the following equation[27]:

$$f_r = \frac{1}{2\pi\sqrt{LC}} \quad (1)$$

Fig. 3 (b) shows that the simulation results of EQC and FEM have identical characteristics where the resonator operates in dual band with $f_{r1} = 1.62$ GHz and $f_{r2} = 2.42$ GHz. This finding indicates that the proposed equivalent circuit model has represented the working principle of the proposed resonator.

D. SENSING AREA DETERMINATION

In this work, the sensor is designed to detect the permittivity of the sample by observing the interaction between the electric field and the permittivity of the sample used. The resonator surface that has a high electric field (E-field) can

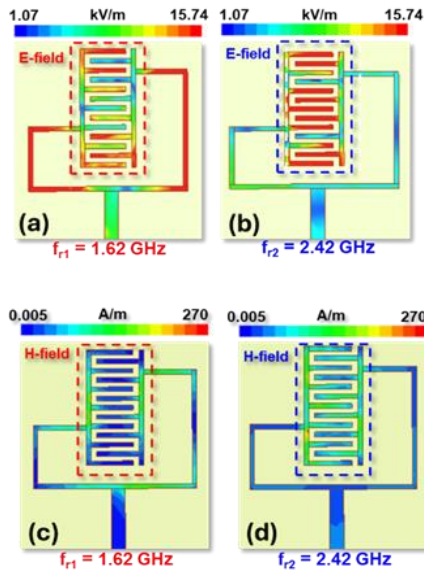

FIGURE 6. E-field and H-field simulations; (a) E-field at $f_{r1} = 1.62$ GHz, (b) E-field at $f_{r2} = 2.41$ GHz, (c) H-field at $f_{r1} = 1.62$ GHz, (d) H-field at $f_{r2} = 2.42$ GHz

be recommended as the sensing area used to place the sample. The sample used is a dielectric sample that does not contain metal. Furthermore, the electric field and magnetic field concentrations of the IDC-based resonator are shown in **Fig.6 (a)**, **Fig.6 (b)**, **Fig.6 (c)** and **Fig.6 (d)**.

Furthermore, **Fig. 6 (a)** and **Fig. 6 (b)** show that the highest electric field concentration of the proposed resonator at $f_{r1}=1.62$ GHz and $f_{r2}=2.42$ GHz is on the IDC surface of the proposed sensor with a range of 1.07 – 15.74 kV/m. In contrast, the magnetic field concentration of the proposed resonator at $f_{r1}=1.62$ GHz and $f_{r2}= 2.42$ GHz are very low and is in the range of 0.005 – 270 A/m as shown in **Fig. 6 (c)** and **Fig. 6 (d)**. These findings indicate that the IDC surface has a high electric field and a low magnetic field so that it becomes a potential location as a sensing area that can be recommended to place samples to be detected. It also shows that the application of the IDC structure has successfully confined the electric field and reduced the magnetic field in the proposed sensor.

Moreover, **Fig. 7 (a)** shows the scenario of dielectric sample placement on the proposed sensor. In this work, the dielectric sample is placed in the sensing area determined based on the highest E-field concentration with dimensions of 10.7 mm x 23 mm x 1 mm. The samples used consist of four types of dielectrics with different permittivity where RO5880 is 2.2, RO4003C is 3.65, FR4 is 4.3 and RO3006 is 6.15. The proposed sensor is connected to a Vector Network Analyzer (VNA) and a PC using a coaxial cable and a USB cable with a frequency range of 1 - 3 GHz and a span of 0.001 GHz. The frequency response of f_{r1} and f_{r2} based on the permittivity change of the dielectric sample is shown in **Fig. 7 (b)**. Overall, the resonant frequencies of $f_{r1} = 1.62$ GHz and

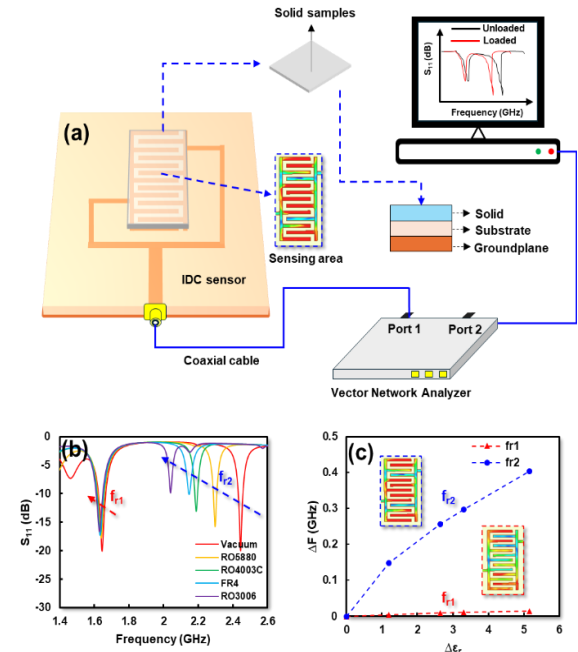

FIGURE 7. (a) Scenario of sample placement of proposed sensor, (b) simulation result of resonance frequency f_{r1} and f_{r2} with permittivity changes, (c) ΔF of proposed sensor for f_{r1} and f_{r2}

$f_{r2} = 2.42$ GHz shift to low frequencies in line with the increase of the permittivity of the sample. Based on the simulation results, f_{r1} shifts from 1.64 GHz to 1.63 GHz while for f_{r2} it shifts from 2.42 GHz to 2.02 GHz for the permittivity range of 1 - 6.15. Furthermore, the ΔF of f_{r1} and f_{r2} are shown in **Fig.7(c)** where for f_{r1} and f_{r2} are 0.01 GHz and 0.4 GHz, respectively.

These findings indicate that the proposed sensor can sense the permittivity change of the dielectric sample based on the frequency change. The resonant frequency of the resonator moves toward the low frequency in line with the increase in the permittivity of the dielectric sample. In addition, f_{r2} is more sensitive than f_{r1} because it has a higher frequency [2] and has a higher electric field concentration compared to f_{r1} as shown in **Fig. 7 (c)**.

III. MEASUREMENT RESULT AND VERIFICATION

This section will discuss the measurement and validation of the proposed sensor, the performance and response of the proposed sensor based on the analysis of the disturbance effects. In this work, the proposed sensor is given a rectangular copper shield disturbance placed on the surface of the sensor.

A. MEASUREMENT OF PROPOSED SENSOR

The next stage is to validate the performance of the proposed sensor to characterize solid materials. In this work, the samples used are solid materials whose permittivity has been known based on the datasheet with a range of 1 - 6.15. Solid materials used as samples include RO5880 with a permittivity of 2.2, RO4003C with a permittivity of 3.65, FR4 with a permittivity of 4.3 and RO3006 with a

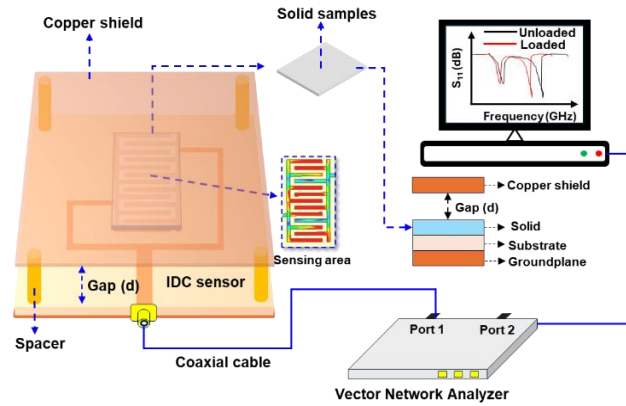

FIGURE 8. Scenario of placing a solid sample on the proposed sensor with copper shield.

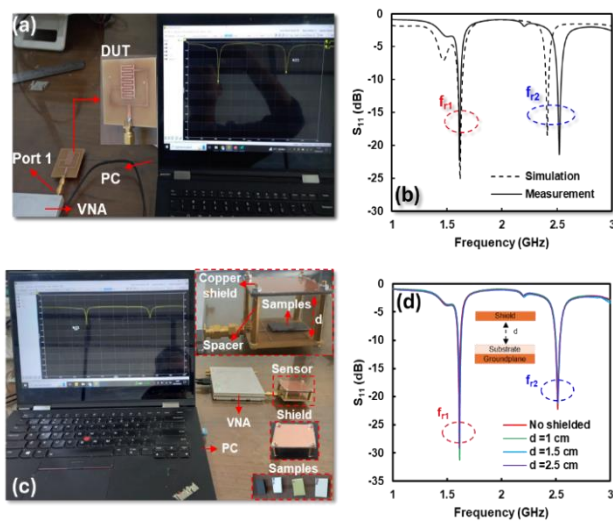

FIGURE 9. Measurement of the proposed sensor; (a) measurement setup, (b) comparison of simulation and measurement, (c) measurement setup of proposed sensor with copper shield, (d) measurement result from proposed sensor with and without shield

permittivity of 6.15. The dimensions of the samples used are adjusted to the location of the sensing area of the proposed sensor, which is 12.7 mm x 25 mm with a sample thickness of 1.6 mm. The measurement scenario and placement of solid samples on the proposed sensor are shown in Fig. 8. In this work, the solid sample with dimensions of 10.7 mm x 23 mm x 1.6 mm is placed on the sensing area surface protected by a rectangular copper shield with dimensions of 50 x 50 mm x 1.58 mm. The copper shield is placed using a brass spacer placed at a certain distance represented by d . It should be noted that the copper shield is proposed as disturbance and also focuses on the electric field so that it is fully concentrated on the sample. The measurement process of the sensor is carried out in the laboratory using a VNA measuring instrument connected to the sensor using a coaxial cable via port 1 while the reading of the measurement results

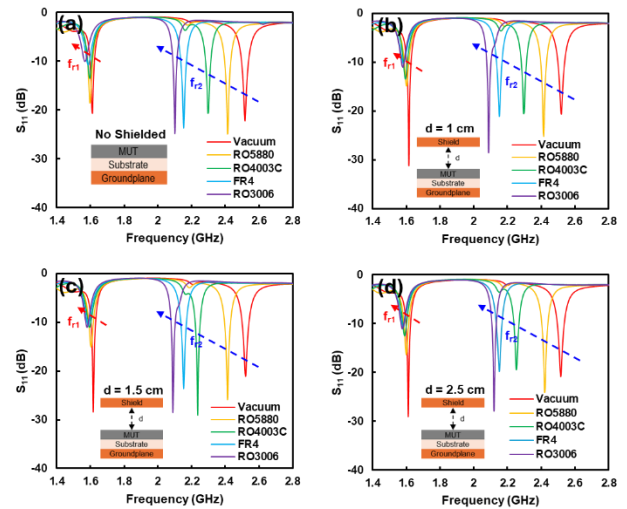

FIGURE 10. Shift of resonance frequency of proposed sensor; (a) without shielded, (b) with copper shielded of $d = 1$ cm, (c) with copper shielded of $d = 1.5$ cm, (d) with copper shielded of $d = 2.5$ cm

is carried out using a PC connected to the VNA via a USB cable. The measurement process is carried out in a closed room with an ambient temperature of 25 °C as shown in Fig. 9 (a). Next, a comparison of the simulation and measurement results of the proposed sensor is shown in Fig. 9 (b). From the measurement results shown in Fig. 9 (b), f_{r1} shifts from 1.62 GHz to 1.61 GHz while f_{r2} shifts from 2.42 GHz to 2.52 GHz. These findings indicate that the proposed sensor has identical performance between simulation and measurement with error rates of 0.6% and 4.1% for f_{r1} and f_{r2} , respectively.

Moreover, the measurement setup of the sensor with a copper shield with a distance of $d = 1 - 2.5$ cm is shown in Fig. 9 (c). Based on measurement results, the resonant frequencies of f_{r1} and f_{r2} are fixed and not affected by the copper shield placed right above the proposed sensor as shown in Fig. 9 (d).

B. PERFORMANCE OF PROPOSED SENSOR WITH ANALYSIS DISTURBANCE EFFECT

In this work, disturbance in the form of rectangular copper shield is placed above the sensor with a distance range of $d = 1 - 2.5$ cm. The performance of the sensor is observed based on the shift in resonance frequency based on the permittivity of the dielectric sample placed in the sensing area. Furthermore, the four solid material samples are placed right above the sensing area surface of the sensing area where the sensor condition without sample (vacuum) with ϵ_r of 1 is used as a reference. In addition, the effects of disturbance are also observed separately when the sensor is without copper shield and using copper shield with a distance of $d = 1$ cm - 2.5 cm as shown in Fig. 10 (a), Fig. 10 (b), Fig. 10 (c) and Fig. 10 (d). Furthermore, the frequency shift of the sensor (Δf), normalized sensitivity and frequency detection resolution (FDR) which is determined based on the following equation[29] [30]:

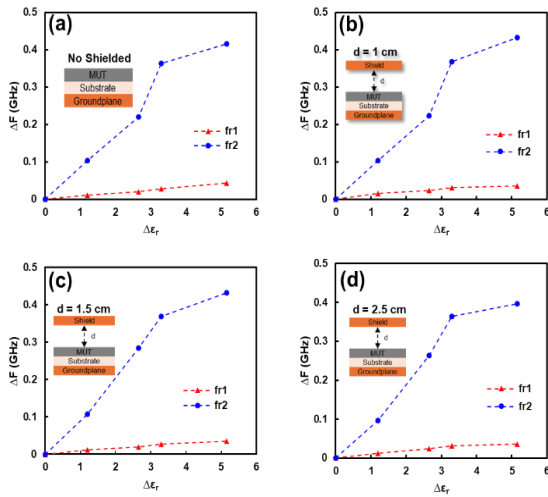

FIGURE 11. ΔF of proposed sensor; (a) without shielded, (b) with cooper shielded of $d = 1$ cm, (c) with cooper shielded of $d = 1.5$ cm, (d) with cooper shielded of $d = 2.5$ cm

$$\Delta f = (f_{\text{unloaded}} - f_{\text{loaded}}) \text{ GHz} \quad (2)$$

$$NS = \frac{1}{\Delta \epsilon_r} \left(\frac{f_{\text{unloaded}} - f_{\text{loaded}}}{f_{\text{unloaded}}} \right) \% \quad (3)$$

$$FDR = \frac{\Delta F}{\Delta \epsilon_r} \text{ GHz} \quad (4)$$

where ΔF represents the frequency shift range, f_{unloaded} is the resonance frequency when the sensor is in a vacuum condition while f_{loaded} is the frequency of the sensor when the sample is loaded, NS is the normalized sensitivity and $\Delta \epsilon_r$ is the difference between the permittivity of the reference sample and the permittivity of the sample loaded to the sensor.

Furthermore, the correlation between the resonant frequency and permittivity changes of the four dielectric samples for shielded condition is shown in **Fig.10 (a)** where f_{r1} shifts from 1.62 GHz to 1.56 GHz while for f_{r2} shifts from 2.52 GHz to 2.1 GHz for the permittivity range of 1 - 6.15. Furthermore, the performance of the sensor with copper shielding for $d = 1$ cm and $d = 1.5$ cm is shown in **Fig. 10 (b)** and **Fig. 10 (c)** where f_{r1} shifts from 1.61 GHz to 1.58 GHz while for f_{r2} from 2.52 GHz to 2.02 GHz, respectively. In line with the previous, f_{r1} shifts from 1.61 GHz to 1.58 GHz and f_{r2} from 2.52 to 2.12 GHz for $d = 2.5$ cm as shown in **Fig. 10 (d)**. The resonant frequency shift of the sensor is represented as ΔF which can be determined using **Eq. (2)**. Furthermore, ΔF of the proposed sensor is shown in **Fig. 11(a)**, **Fig. 11(b)**, **Fig. 11(c)** and **Fig. 11(d)**.

From the measurement results, the maximum ΔF of the proposed sensor has a stable performance where for f_{r1} is 0.03 GHz and f_{r2} is 0.4 GHz for conditions with or without copper shielding. In addition, the same findings for the Frequency Detection Resolution (FDR) of the proposed sensor which can be determined using **Eq. (4)** where for the maximum FDR for f_{r1} is 0.009 GHz / $\Delta \epsilon_r$ while for f_{r2} is 0.11

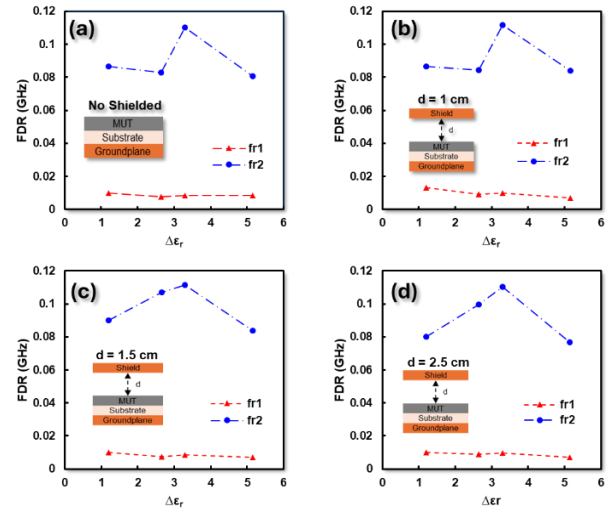

FIGURE 12. Frequency detection resolution of proposed sensor; (a) without shielded, (b) with cooper shielded of $d = 1$ cm, (c) with cooper shielded of $d = 1.5$ cm, (d) with cooper shielded of $d = 2.5$ cm

GHz / $\Delta \epsilon_r$ for both conditions with or without shielding as shown in **Fig. 12(a)**, **Fig. 12(b)**, **Fig. 12(c)** and **Fig. 12(d)**.

These findings indicate that the performance of the proposed sensor is not significantly affected by the addition of disturbance in the form of a copper shield. ΔF and FDR of the proposed sensor are relatively stable to detect the permittivity of dielectric samples with a permittivity range of 1 - 6.15.

The normalized sensitivity (NS) of the proposed sensor can be determined based on **Eq. (3)**. Furthermore, the NS of the proposed sensor for conditions with or without copper shield are shown in **Fig. 13 (a)**, **Fig. 13 (b)**, **Fig. 13 (c)** and **Fig. 13 (d)**. Based on the measurement results, the NS for the sensor with the condition without copper shield is in the range of 0.53% - 0.62% for f_{r1} while for f_{r2} it is in the range of 3.21% - 4.38% as shown in **Fig. 13(a)**. Furthermore, the NS for the sensor condition with copper shield for $d = 1$ cm is in the range of 0.43% - 0.83 for f_{r1} and f_{r2} in the range of 3.33 - 4.43% as shown in **Fig. 13 (b)**. In addition, the NS for the sensor with copper shield condition for $d = 1.5$ cm is in the range of 0.43% - 0.62% for f_{r1} while for f_{r2} is in the range of 3.33% - 4.43% as shown in **Fig. 13 (c)**. Finally, the NS for the sensor with copper shield for $d = 2.5$ cm is presented by **Fig. 13 (d)** where f_{r1} is in the range of 0.43% - 0.62% while for f_{r2} is in the range of 3.06% - 4.38%.

This finding indicates that the NS of the sensor with copper and without shield is stable because the electric field is more concentrated in the sensing area of the proposed sensor. This finding is also in line with the simulation where the E-field concentration of the IDC-based sensor is more dominant compared to the H-field so that the electric field from the sensor is focused in the sensing area of the sensor. In addition, the NS of the sensor without and with copper shield for the range $d = 1$ cm - 2.5 cm has a stable performance in

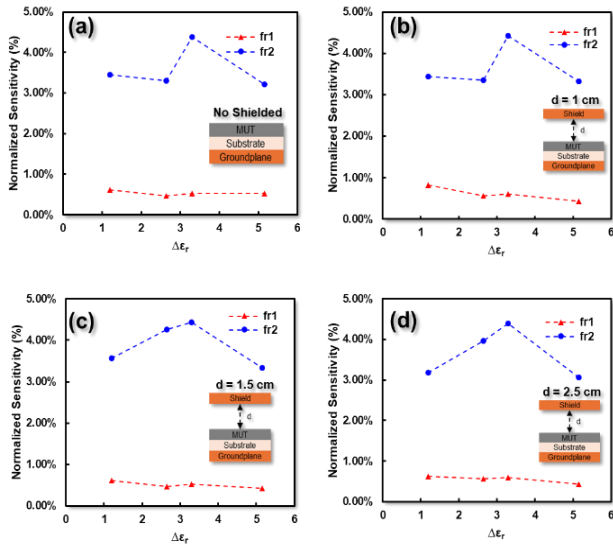

FIGURE 13. Normalized sensitivity of proposed sensor; (a) without shielded, (b) with cooper shielded of $d = 1$ cm, (c) with cooper shielded of $d = 1.5$ cm, (d) with cooper shielded of $d = 2.5$ cm

the range of 0.4% - 0.8 % and 3% - 4% for f_{r1} and f_{r2} , respectively .

This finding also shows that the addition of copper shield with a range of $d = 1$ cm - 2.5 cm as a disturbance has no significant effect on the performance of the proposed sensor and can be used to confined the electric field of the proposed sensor in the specific sensing area.

C. ACCURACY OF PROPOSED SENSOR

Furthermore, the correlation between resonance frequency and permittivity can be derived into a third-order polynomial equation that can be used to determine the permittivity of solid materials [31]–[33] as shown in Fig.15 (a), Fig. 15(b), Fig. 15(c), Fig. 15(d), Fig. 15(e), Fig. 15(f), Fig. 15(g) and Fig. 15(h). Based on the correlation between the resonant frequency and permittivity from the measurement result, the permittivity of the dielectric sample for the condition without copper shielding can be determined based on the third-order polynomial equation as follows:

$$\epsilon_{r1} = a_1 f_{r1}^3 + a_2 f_{r1}^2 - a_3 f_{r1} + a_4 \quad (4)$$

$$\epsilon_{r2} = b_1 f_{r2}^3 + b_2 f_{r2}^2 - b_3 f_{r2} + b_4 \quad (5)$$

where ϵ_{r1} is the permittivity of the sample based on f_{r1} and ϵ_{r2} is the permittivity based on f_{r2} . Furthermore, based on the third order polynomial equation, the values of $a_1 = -78.685$, $a_2 = 174.14$, $a_3 = 75667$, $a_4 = 0$, $b_1 = -156.76$, $b_2 = 1091.2$, $b_3 = 2537$ and $b_4 = 1973.3$ are obtained for conditions without copper shield as shown in Fig. 15 (a) and Fig. 15 (b). Next, for $d = 1$ cm the values are obtained from $a_1 = -143572$, $a_2 = 691050$, $a_3 = 1E+06$, $a_4 = 593083$, $b_1 = -133.95$, $b_2 = 930.72$, $b_3 = 2161.1$ and $b_4 = 1680$ while for $d = 1.5$ cm the values are obtained from $a_1 = -54026$, $a_2 = 260387$, $a_3 = 418443$, $a_4 =$

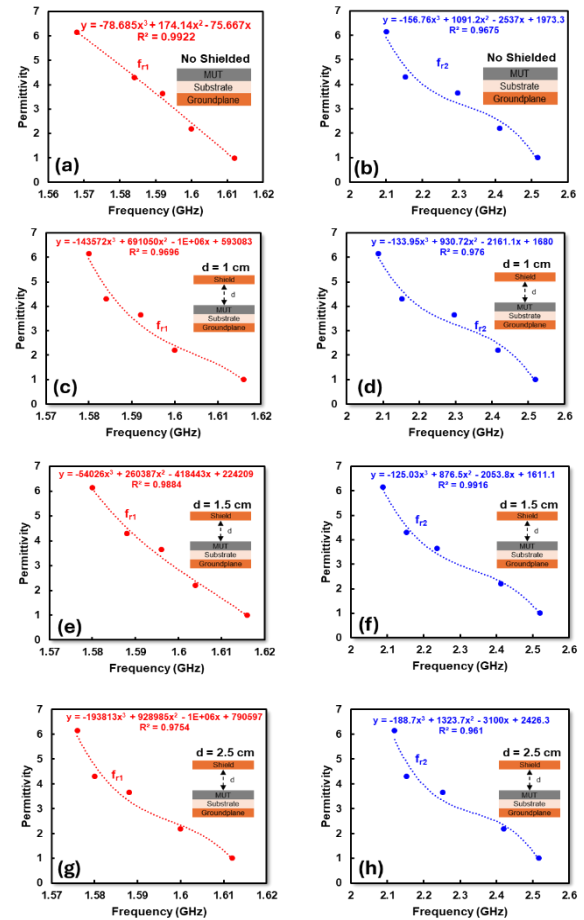

FIGURE 14. Polynomial equation based on resonant frequency and permittivity; (a) without shielded for f_{r1} , (b) without shielded for f_{r2} , (c) with cooper shielded of $d = 1$ cm for f_{r1} , (d) with cooper shielded of $d = 1$ cm for f_{r2} , (e) with cooper shielded of $d = 1.5$ cm for f_{r1} , (f) with cooper shielded of $d = 1.5$ cm for f_{r2} , (g) with cooper shielded of $d = 2.5$ cm for f_{r1} , (h) with cooper shielded of $d = 2.5$ cm for f_{r2}

224209, $b_1 = -125.03$, $b_2 = 876.5$, $b_3 = 2053.8$ and $b_4 = 1611.1$ as shown in Fig. 15 (c), Fig. 15 (d), Fig. 15 (e), Fig. 15 (f). Finally, for the condition $d = 2.5$ cm the values are obtained from $a_1 = -19381$, $a_2 = 928985$, $a_3 = -1E+06$, $a_4 = 790597$, $b_1 = -188.7$, $b_2 = 1323.7$, $b_3 = -3100$ and $b_4 = 2426.3$ as shown in Fig. 15 (g) and Fig. 15 (h). Overall, the permittivity based on calculations for f_{r1} and f_{r2} is shown in Table I and Table II.

TABLE I
ACCURACY OF PROPOSED SENSOR FOR 1ST RESONANT FREQUENCY

ϵ_r reference	No shielded		Shielded cooper					
	ϵ_r calc.	Acc. (%)	$d = 1$ cm		$d = 1.5$ cm		$d = 2.5$ cm	
			ϵ_r calc.	Acc. (%)	ϵ_r calc.	Acc. (%)	ϵ_r calc.	Acc. (%)
1	0.94	93.54	0.98	98.25	0.97	97.36	0.97	97.20
2.2	2.44	89.21	2.39	91.51	2.37	92.13	2.33	93.92
3.65	3.41	93.32	3.23	88.61	3.34	91.46	3.32	90.84
4.3	4.35	98.86	4.77	89.14	4.52	94.82	4.75	89.50
6.15	6.16	99.86	5.93	96.39	6.09	99.06	5.93	96.37

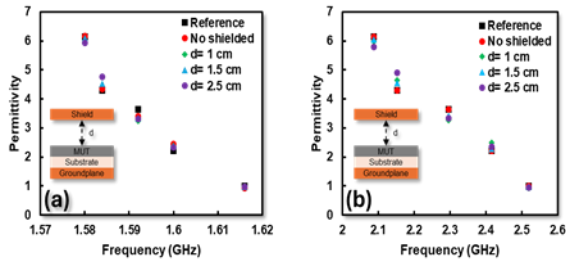

FIGURE 15. Accuracy of proposed sensor; (a) without shielded, (b) with cooper shielded of $d = 1$ cm, (c) with cooper shielded of $d = 1.5$ cm, (d) with cooper shielded of $d = 2.5$ cm

TABLE II

ACCURACY OF PROPOSED SENSOR FOR 2ND RESONANT FREQUENCY

ϵ_r reference	No shielded		Shielded cooper					
	ϵ_r calc.	Acc. (%)	$d = 1$ cm		$d = 1.5$ cm		$d = 2.5$ cm	
			ϵ_r calc.	Acc. (%)	ϵ_r calc.	Acc. (%)	ϵ_r calc.	Acc. (%)
1	0.91	91.39	0.92	91.73	0.97	97.26	0.95	94.94
2.2	2.51	86.00	2.48	87.11	2.28	96.21	2.34	93.52
3.65	3.23	88.58	3.27	89.57	3.44	94.11	3.33	91.35
4.3	4.72	90.12	4.64	92.04	4.56	93.96	4.89	86.24
6.15	5.92	96.31	5.99	97.36	6.05	98.36	5.78	94.01

Based on Table I and Table II, the proposed sensor has good average accuracy where for the condition without copper shield it is at 94.96% and 90.48% for f_{r1} and f_{r2} , respectively. Furthermore, the average accuracy for f_{r1} and f_{r2} for the sensor with copper shield is 92.78% and 91.72% for $d = 1$ cm and for $d = 1.5$ cm the average accuracy is 94.97% and 95.98% while for $d = 2.5$ cm, the average accuracy is at 93.57% and 92.01%, respectively.

This finding shows that the best average accuracy is obtained when $d = 1.5$ cm. In addition, the sensor has a consistent average accuracy for conditions with and without shield. In addition, the sensor has a consistent average accuracy for conditions with and without shield compared with reference permittivity as shown in Fig. 15 (a) and Fig. 15 (b). This finding also shows that the proposed sensor has high performance and is not significantly affected by disturbances placed directly above the sensor with range of $d = 1$ cm – 2.5 cm.

IV. VALIDATION WITH PREVIOUS WORKS

A thorough evaluation comparing the proposed sensor's performance with previous studies is conducted, as detailed in Table III. A fair comparison with previous work is proposed by observing the performance of the sensor in terms of the method, permittivity range, resonance frequency (f_r), Frequency Detection Resolution (FDR), Normalized Sensitivity (NS) and accuracy. In addition, other performances that are compared are dual band

characteristics, e-field localization, disturbance effect analysis and also high stability of the proposed sensor.

Previous work proposed a microwave sensor using a dual-port resonator for permittivity detection of solid materials based on SRR [8],[10],[32], IDC structure [19],[20] and CSRR[13]. The sensor has good performance with a maximum accuracy of 96% - 98% and a normalized sensitivity of 1.34% - 5.38%. However, the proposed sensor only supports transmission mode-based measurements and requires a two-port network analyzer for characterization, which can increase the complexity and cost of the measurement setup.

Previous studies introduced a single-port resonator incorporating a slot for permittivity detection of dielectric samples, achieving an accuracy of 98.80% and a normalized sensitivity of 5.24% [23]. However, the sensor's electric field remains inadequately localized and focused on the sensing area, potentially leading to measurement inaccuracies in the presence of interference or disturbances. In addition, the proposed sensor only operates at a single resonant frequency. Moreover, a single-port microwave sensor with dual band performance utilizing U-shaped [24] and T-shaped resonators [26] was proposed in another study, featuring independent characteristics for simultaneous detection of solid material permittivity and long-distance sensing. The electric field of the resonator was localized on its arm, designated as the sensing area. However, the study did not include an analysis of disturbance effects, leaving the stability of the proposed sensor under disturbed conditions unverified.

Previous work introduced a single-port microwave sensor employing aperture coupling [25] and an artificial magnetic conductor [21]. The electric field was localized on a separate substrate, designated as the sensor's sensing area. However, the proposed structure features a multilayer design, making it more complex to implement. Furthermore, the study did not include an analysis of disturbance effects, leaving the sensor's stability under such conditions unverified. This work provides an excellent solution to produce a microwave sensor using a single-port resonator that has high stability against disturbances. In this work, an interdigital capacitor structure is introduced to confine the E-field of the sensor to focus it on the sensing area of the sensor. In addition, the interdigital capacitor structure also reduces the H-field so that the E-field becomes more dominant. The stability of the sensor is evaluated and confirmed by placing a disturbance in the form of a rectangular copper shield placed directly above the sensor. The performance and stability of the sensor are observed in conditions without and with copper shielding for a distance range of $d = 1$ cm - 2.5 cm. From the measurement results, the sensor has high stability both without and with disturbance with a Frequency Detection Resolution (FDR) of 0.009 - 0.4 GHz/ $\Delta\epsilon_r$, a Normalized Sensitivity (NS) of 0.4% - 4.4%, and an average accuracy of 90% - 95% for both resonance frequencies, respectively.

TABLE III
COMPARISON WITH PREVIOUS WORKS

Ref.	Method	Freq (GHz)	Range of ϵ_r	Performance			Num. of port	Dual-band performance	Confined E-field region	Disturbance analysis effect	High stability performance
				Max. FDR (GHz)	Max NS. (%)	Max Acc. (GHz)					
[8]	SRR	0.39	1 – 7.33	0.102	1.625	98.20	1	-	Yes	-	-
[10]	SSRR with spurlines	2.22	1 – 4.40	0.030	1.340	98.36	2	-	Yes	-	-
[13]	CSRR	2.65	1 – 3.00	0.150	5.380	97.71	2	-	Yes	-	-
[19]	IDC	2.65	1 – 6.15	0.373	4.300	99.99	2	-	Yes	-	-
[20]	IDC	2.35 / 5.79	1 – 10.5	0.150	3.980	99.99	2	-	Yes	-	-
[21]	Artificial Magnetic Conductor	4.04	1 – 4.40	0.070	1.890	96.48	1	-	Yes	-	-
[23]	Slot-loaded patch	2.50	1 – 10.20	0.072	5.240	98.80	1	-	-	-	-
[24]	Dual U-shaped	1.20 / 2.10	1 – 4.30	0.007	1.150	99.02	1	Yes	Yes	-	-
[25]	Aperture coupling	9.54 / 12.30	1 – 12.50	0.078	0.640	92.30	1	Yes	Yes	-	-
[26]	Dual T-shaped with IDC	1.64 / 2.43	1 – 6.15	0.016	0.003	95.99	1	Yes	Yes	-	-
[32]	SRR	1.24 / 2.08	1 – 6.00	0.050	4.101	96.97	2	Yes	Yes	-	-
This work	Asymmetric branch feed with IDC	1.61 / 2.52	1 – 6.15	0.110	4.330	95.98	1	Yes	Yes	Yes	Yes

V. CONCLUSION

This paper has successfully designed and realized a high stability single port dual-band microwave sensor using interdigital structure with asymmetry branch feedline for solid material characterization with permittivity range 1 - 6.15. The proposed sensor operates at two different resonance frequencies $f_{r1} = 1.61$ GHz and $f_{r2} = 2.52$ GHz. Based on the measurement results, the proposed sensor has high stability both without and with disturbance for $d = 1$ cm - 2.5 cm with a Frequency Detection Resolution (FDR) of 0.009 - 0.4 GHz/ $\Delta\epsilon_r$, a Normalized Sensitivity (NS) of 0.4% - 4.4%, and an average accuracy of 90% - 95% for both resonance frequencies, respectively. Therefore, this sensor can be recommended for several applications including biomedical industry, medicine and material quality control especially for outdoor measurements that are potentially affected by electromagnetic interference and disturbance.

VI. ACKNOWLEDGMENT

This work is supported by Research and Community Services Institute of Universitas Trisakti and Ministry of Research, Technology and Higher Education of Republik Indonesia through a competitive research grant under the KATALIS Research Scheme fiscal year of 2024 with contract number of 058/E5/PG.02.00/PL.BATCH.2/2024 and 1091/LL3/AL.04/2024.

REFERENCES

- [1] K. S. L. Parvathi and S. R. Gupta, "Ultra-high-Sensitivity and Compact EBG-Based Microwave Sensor for Liquid Characterization," *IEEE Sensors Lett.*, vol. 6, no. 4, pp. 19–22, 2022, doi: 10.1109/LESENS.2022.3159800.
- [2] A. Armghan, T. M. Alanazi, A. Altaf, and T. Haq, "Characterization of Dielectric Substrates Using Dual Band Microwave Sensor," *IEEE Access*, vol. 9, pp. 62779–62787, 2021, doi: 10.1109/ACCESS.2021.3075246.
- [3] Z. Shaterian and M. Mrozowski, "Multifunctional Bandpass Filter/Displacement Sensor Component," *IEEE Access*, vol. 11, no. March, pp. 27012–27019, 2023, doi: 10.1109/ACCESS.2023.3258545.
- [4] A. Aquino, C. G. Juan, B. Potelon, and C. Quendo, "Dielectric Permittivity Sensor Based on Planar Open-Loop Resonator," *IEEE Sensors Lett.*, vol. 5, no. 3, pp. 2021–2024, 2021, doi: 10.1109/LESENS.2021.3055544.
- [5] W. A. Jabbar *et al.*, "Design and Fabrication of Smart Home with Internet of Things Enabled Automation System," *IEEE Access*, vol. 7, pp. 144059–144074, 2019, doi: 10.1109/ACCESS.2019.2942846.
- [6] A. Ebrahimi, J. Scott, and K. Ghorbani, "Ultra-high-Sensitivity Microwave Sensor for Microfluidic Complex Permittivity Measurement," *IEEE Trans. Microw. Theory Tech.*, vol. 67, no. 10, pp. 4269–4277, 2019, doi: 10.1109/TMTT.2019.2932737.
- [7] P. Jahangiri, M. Naser-Moghadasi, B. Ghalamkari, and M. Dousti, "A new planar microwave sensor for fat-measuring of meat based on SRR and periodic EBG structures," *Sensors Actuators A Phys.*, vol. 346, no. June, p. 113826, 2022, doi: 10.1016/j.sna.2022.113826.
- [8] K. Xu *et al.*, "Novel Microwave Sensors Based on Split Ring Resonators for Measuring Permittivity," *IEEE Access*, vol. 6, pp. 26111–26120, 2018, doi: 10.1109/ACCESS.2018.2834726.
- [9] W. Liu, J. Zhang, and K. Huang, "Dual-Band Microwave Sensor Based on Planar Rectangular Cavity Loaded with Pairs of Improved Resonator for Differential Sensing Applications," *IEEE Trans.*

- Instrum. Meas.*, vol. 70, 2021, doi: 10.1109/TIM.2021.3118090.
- [10] R. A. Alahnomi, Z. Zakaria, E. Ruslan, S. R. Ab Rashid, and A. A. Mohd Bahar, "High-Q sensor based on symmetrical split ring resonator with spurlines for solids material detection," *IEEE Sens. J.*, vol. 17, no. 9, pp. 2766–2775, 2017, doi: 10.1109/JSEN.2017.2682266.
- [11] M. Saadat-Safa, V. Nayyeri, M. Khanjarian, M. Soleimani, and O. M. Ramahi, "A CSRR-Based Sensor for Full Characterization of Magneto-Dielectric Materials," *IEEE Trans. Microw. Theory Tech.*, vol. 67, no. 2, pp. 806–814, 2019, doi: 10.1109/TMTT.2018.2882826.
- [12] M. Abdolrazzagh, N. Kazemi, V. Nayyeri, and F. Martin, "AI-Assisted Ultra-High-Sensitivity/Resolution Active-Coupled CSRR-Based Sensor with Embedded Selectivity," *Sensors*, vol. 23, no. 13, pp. 1–20, 2023, doi: 10.3390/s23136236.
- [13] M. A. H. Ansari, A. K. Jha, and M. J. Akhtar, "Design and Application of the CSRR-Based Planar Sensor for Noninvasive Measurement of Complex Permittivity," *IEEE Sens. J.*, vol. 15, no. 12, pp. 7181–7189, 2015, doi: 10.1109/JSEN.2015.2469683.
- [14] A. A. Mohd Bahar, Z. Zakaria, M. K. Md Arshad, R. A. Alahnomi, A. I. Abu-Khadrah, and W. Y. Sam, "Microfluidic biochemical sensor based on circular SIW-DMS approach for dielectric characterization application," *Int. J. RF Microw. Comput. Eng.*, vol. 29, no. 9, pp. 1–13, 2019, doi: 10.1002/mmce.21801.
- [15] A. A. Mohd Bahar, Z. Zakaria, M. K. Md. Arshad, A. A. M. Isa, Y. Dasril, and R. A. Alahnomi, "Real Time Microwave Biochemical Sensor Based on Circular SIW Approach for Aqueous Dielectric Detection," *Sci. Rep.*, vol. 9, no. 1, pp. 1–12, 2019, doi: 10.1038/s41598-019-41702-3.
- [16] J. Yeo and J. I. Lee, "High-sensitivity microwave sensor based on an interdigital-capacitor-shaped defected ground structure for permittivity characterization," *Sensors (Switzerland)*, vol. 19, no. 3, 2019, doi: 10.3390/s19030498.
- [17] S. Aiswarya, S. K. Menon, M. Donelli, and L. Meenu, "Development of a microwave sensor for solid and liquid substances based on closed loop resonator," *Sensors*, vol. 21, no. 24, pp. 1–34, 2021, doi: 10.3390/s21248506.
- [18] L. Ali *et al.*, "Design and optimization of microwave sensor for the non-contact measurement of pure dielectric materials," *Electron.*, vol. 10, no. 24, 2021, doi: 10.3390/electronics10243057.
- [19] L. Ali *et al.*, "Design and Optimization of Interdigitated Microwave Sensor for Multidimensional Sensitive Characterization of Solid Materials," *IEEE Sens. J.*, vol. 21, no. 20, pp. 22814–22822, 2021, doi: 10.1109/JSEN.2021.3105410.
- [20] C. Wang *et al.*, "High-Accuracy Complex Permittivity Characterization of Solid Materials Using Parallel Interdigital Capacitor-Based Planar Microwave Sensor," *IEEE Sens. J.*, vol. 21, no. 5, pp. 6083–6093, 2021, doi: 10.1109/JSEN.2020.3041014.
- [21] W. J. Wu and G. Wang, "A modified AMC-based antenna sensor for contactless measurement of complex permittivity," *Meas. J. Int. Meas. Confed.*, vol. 206, no. June 2022, p. 112261, 2023, doi: 10.1016/j.measurement.2022.112261.
- [22] Q. Shi, X. W. Xuan, H. K. Nie, Z. Y. Wang, and W. Wang, "Antenna Sensor Based on AMC Array for Contactless Detection of Water and Ethanol in Oil," *IEEE Sens. J.*, vol. 21, no. 19, pp. 21503–21510, 2021, doi: 10.1109/JSEN.2021.3102294.
- [23] J. Yeo and J. I. Lee, "Slot-loaded microstrip patch sensor antenna for high-sensitivity permittivity characterization," *Electron.*, vol. 8, no. 5, 2019, doi: 10.3390/electronics8050502.
- [24] S. Alam, Z. Zakaria, I. Surjati, N. A. Shairi, M. Alaydrus, and T. Firmansyah, "Dual-Band Independent Permittivity Sensor Using Single-Port with a Pair of U-Shaped Structures for Solid Material Detection," *IEEE Sens. J.*, vol. 22, no. 16, pp. 16111–16119, 2022, doi: 10.1109/JSEN.2022.3191345.
- [25] M. Behdani, M. M. H. Kalateh, H. Saghlatoon, J. Melzer, and R. Mirzavand, "High-Resolution Dielectric Constant Measurement Using a Sensor Antenna with an Allocated Link for Data Transmission," *IEEE Sens. J.*, vol. 20, no. 24, pp. 14827–14835, 2020, doi: 10.1109/JSEN.2020.3012055.
- [26] S. Alam *et al.*, "Collaboratively Far-Field and Near-Field Regions for Dual-Modalities Microwave Permittivity Sensor Using T-Shaped Resonator Embedded With IDC," *IEEE Sensors Lett.*, vol. 8, no. 7, pp. 8–11, 2024, doi: 10.1109/LSENS.2024.3415362.
- [27] S. Alam, Z. Zakaria, I. Surjati, N. A. Shairi, M. Alaydrus, and T. Firmansyah, "Multifunctional of dual-band permittivity sensors with antenna using multicascoded T-shaped resonators for simultaneous measurement of solid materials and data transfer capabilities," *Meas. J. Int. Meas. Confed.*, vol. 217, no. November 2022, p. 113078, 2023, doi: 10.1016/j.measurement.2023.113078.
- [28] A. Ebrahimi, F. J. Tovar-Lopez, J. Scott, and K. Ghorbani, "Differential microwave sensor for characterization of glycerol-water solutions," *Sensors Actuators, B Chem.*, vol. 321, p. 128561, 2020, doi: 10.1016/j.snb.2020.128561.
- [29] S. Kiani, P. Rezaei, and M. Navaei, "Dual-sensing and dual-frequency microwave SRR sensor for liquid samples permittivity detection," *Meas. J. Int. Meas. Confed.*, vol. 160, p. 107805, 2020, doi: 10.1016/j.measurement.2020.107805.
- [30] S. Kiani, P. Rezaei, and M. Fakhr, "Real-Time Measurement of Liquid Permittivity Through Label-Free Meandered Microwave Sensor," *IETE J. Res.*, 2023, doi: 10.1080/03772063.2023.2231875.
- [31] R. C. Caleffo and F. S. Correr, "Liquids electrical characterization sensor using a hybrid SIW resonant cavity," *Microw. Opt. Technol. Lett.*, vol. 60, no. 2, pp. 445–449, 2018, doi: 10.1002/mop.30983.
- [32] A. A. Al-Behadili, I. A. Mocanu, N. Codreanu, and M. Pantazica, "Modified split ring resonators sensor for accurate complex permittivity measurements of solid dielectrics," *Sensors (Switzerland)*, vol. 20, no. 23, pp. 1–18, 2020, doi: 10.3390/s20236855.
- [33] S. Lim, C. Y. Kim, and S. Hong, "Simultaneous Measurement of Thickness and Permittivity by Means of the Resonant Frequency Fitting of a Microstrip Line Ring Resonator," *IEEE Microw. Wirel. Components Lett.*, vol. 28, no. 6, pp. 539–541, 2018, doi: 10.1109/LMWC.2018.2833202.



Syah Alam was born in Jakarta, Indonesia. He received Bachelor Education of Engineering (S.Pd) degree in electrical engineering from Universitas Pendidikan Indonesia (UPI) and M.Eng (M.T) degree in telecommunication engineering from Graduate Programe of Electrical Engineering Universitas Trisakti in 2010 and 2012, respectively. In 2018, he joined the Department of Electrical Engineering Universitas Trisakti as a researcher and lecturer. In 2024, he is completed his PhD at Universiti Teknikal Melaka Malaysia (UTeM) in the field of Electronic Engineering (RF and Microwave). His research interests include microstrip antenna, and microwave sensors for various applications.



Indra Surjati was born in Bangkok, Thailand. She received Bachelor of Engineering (Ir.) degree in electrical engineering and M.Eng (M.T) degree in telecommunication engineering from Graduate Programe of Electrical Engineering Universitas Trisakti in 1996, respectively. In 2004 she completed his PhD in Electrical Engineering Department at the University of Indonesia and in 2011 she was confirmed as Professor in the Department of Electrical Engineering at Trisakti. Her research interests include microstrip antenna and microwave circuit for various applications.



Lydia Sari received the B.S. degrees in electrical engineering from Universitas Trisakti, Jakarta, Indonesia in 1998. She received the M.S. and Ph.D degrees in electrical engineering from University of Indonesia in 2002 and 2010, respectively. She is currently a faculty member in Electrical Engineering Department, Universitas Trisakti. Her research interests include wireless communications and information theory.



Raden Deiny Mardian received a bachelor's degree in 1998 and a master's degree in 2001, both in electrical engineering, from Universitas Trisakti, Jakarta, Indonesia. In early 2023 he received a doctoral degree in electrical engineering from Universitas Indonesia, Depok, Indonesia. He has published several journal papers and conference proceedings. He is currently a lecturer at the Electrical Engineering Department, Faculty of Industrial Technology, Universitas Trisakti, Jakarta, Indonesia. His research interests are mobile and wireless communication technology, digital broadcasting, quality of service, and quality of experience—all his research concerns technical and regulatory policy management.



Teguh Firmansyah, was born in Subang, Indonesia. He received a B.Eng. and M. Eng degree in electrical engineering from the Department of Electrical Engineering, Universitas Indonesia, in 2010 and 2012, respectively. In 2022, He received his Dr. Eng degree from Shizuoka University Japan as the best graduate. In 2012, he joined the Department of Electrical Engineering, Universitas Sultan Ageng Tirtayasa, as a Researcher and a Lecturer. He holds two patents for wideband antenna and multiband antenna. His research interests include microwave circuits for various applications and developing multifunctional sensors using acoustic, plasmonic, and microwave resonators.



Mudrik Alaydrus was born in Jakarta, Indonesia. He received the Dipl.-Ing. and Dr.-Ing. degrees in Electrical Engineering from Universitaet Hannover and Universitaet Wuppertal, in 1997 and 2001, respectively. Since 2003, he has worked at Universitas Mercu Buana, Jakarta. Dr. Alaydrus is Senior Member of IEEE and member of Verein der Deutschen Elektroingenieure (VDE). His current researches include microwave and millimeter wave components, wireless power transfers, wireless sensor networks, interaction between electromagnetics and materials, and mathematical modeling in signal processing.



Zahrialdha Zakaria was born in Johor, Malaysia. He received the B. Eng. and M. Eng. In Electrical and Electronic Engineering from the Universiti Teknologi Malaysia in 1998 and 2004 respectively, and the PhD degree in Electrical & Electronic Engineering from the Institute of Microwaves and Photonics (IMP), University of Leeds, United Kingdom in 2010. From 1998 to 2002, he was with STMicroelectronics, Malaysia where he worked as Product Engineer. He is currently a Professor at Microwave Research Group (MRG), Faculty of Electronic & Computer Engineering, University Teknikal Malaysia Melaka (UTeM). His research interests include variety of microwave devices development such as planar and nonplanar microwave filters, resonators, amplifiers and antennas. He also investigates energy harvesting and sensors.

2nd decision

Decision letter (Revision 1)

High Stability Single-Port Dual Band Microwave Sensor Based on Interdigital Capacitor Structure with Asymmetry Branch Feedline

Subject IEEE Access - Decision on Manuscript ID Access-2025-00351

Date sent 27 January 2025 at 13:08 GMT+7

From ieeeaccess@ieee.org

To > [Show 11 addresses](#)

CC wsh.zhao@gmail.com

27-Jan-2025

Dear Dr. Alam:

Your manuscript entitled "High Stability Single-Port Dual Band Microwave Sensor Based on Interdigital Capacitor Structure with Asymmetry Branch Feedline" has been accepted for publication in IEEE Access. The comments of the reviewers who evaluated your manuscript are included at the foot of this letter. We ask that you make minor changes to your manuscript based on those comments, before uploading final files.

Please be advised that you are **not permitted** to add or remove authors or references post-acceptance, regardless of the reviewers' request(s).

Any request to add an author post-acceptance will be denied. However, we encourage you to check the formatting of your references to ensure that they are accurate in terms of bibliographic details as well as consistent with [IEEE style](#). Additionally, please take this opportunity to improve the English grammar and check spelling, as the article is only lightly edited before publication.

You can submit your final files through the [IEEE Author Portal](#).

All files intended for publication need to be submitted during this step, even if some files are unchanged from the initial submission. If you do not submit all files during this step, it can delay the publication of your article, or result in certain files not being published. **Please be advised that once you submit final files the article will be considered published and cannot be withdrawn.**

To assist you with preparing your final files, attached please find a Final Files Checklist.

Once you have completed the submission of your final files, the **accepted version** of your article will be posted Early Access on IEEE *Xplore* within 2-3 business days. Within 7-10 business days the corresponding author will receive your page proofs, at which point you can make **minor** edits as necessary. Once the corresponding author approves the proofs, the final version will replace the Early Access version on IEEE *Xplore*.

For more information on what to expect after you submit final files, please visit our [Post Acceptance Guide](#).

After you submit final files you will automatically be directed to the Electronic Copyright Form. Once the copyright information is completed, within a few business days you will receive an email from Copyright Clearance Center (CCC) to settle your APC balance of \$1,995 USD plus applicable local taxes by check, credit card, or wire transfer. **Please note that once you submit final files your article is considered published, and you are responsible for covering the cost of the APC.** If you need assistance with the payment process, please contact CCC Customer Service at IEEESupport@copyright.com.

Thank you for your fine contribution. On behalf of the Editors of IEEE *Access*, we look forward to your continued contributions to IEEE *Access*.

Sincerely,

Prof. Wen-Sheng Zhao
Associate Editor, IEEE *Access*
wsh.zhao@gmail.com

Reviewer(s)' Comments to Author:

Reviewer: 1

Comments:
N/A

Additional Questions:

Please confirm that you have reviewed all relevant files, including supplementary files and any author response files, which can be found in the

"View Author's Response" link above (author responses will only appear for resubmissions): Yes, all files have been reviewed

- 1) Does the paper contribute to the body of knowledge?: Yes
- 2) Is the paper technically sound?: Yes
- 3) Is the subject matter presented in a comprehensive manner?: Yes
- 4) Are the references provided applicable and sufficient?: Yes
- 5) Are there references that are not appropriate for the topic being discussed?: Yes
- 5a) If yes, then please indicate which references should be removed.:

Reviewer: 2

Comments:

Dear author,
Your manuscript is know easily understood by the reader.
Good job.
Thank you

Additional Questions:

Please confirm that you have reviewed all relevant files, including supplementary files and any author response files, which can be found in the "View Author's Response" link above (author responses will only appear for resubmissions): Yes, all files have been reviewed

- 1) Does the paper contribute to the body of knowledge?: yes
- 2) Is the paper technically sound?: Yes
- 3) Is the subject matter presented in a comprehensive manner?: yes
- 4) Are the references provided applicable and sufficient?: yes
- 5) Are there references that are not appropriate for the topic being discussed?: No
- 5a) If yes, then please indicate which references should be removed.:

Reviewer: 3

Comments:

The paper proposes a single-port IDC based resonator for permittivity detection of solid materials with a permittivity range of 1 - 6.15. The microwave sensor is designed using a single-port resonator operating at two different resonant frequencies. The main comments are as follows:

1. As the dielectric constants of most solid materials are not frequency dependent, the reviewer wonder the necessity of proposing a dual-band sensor.
2. There will be air gap between the IDC surface and the solid materials. To the reviewer's knowledge, the air gap will have significant effect on the sensing results. How the authors can reduce this effect?
3. For further theoretical supporting, the reviewer would suggest the authors to refer to the IEEE T-MTT paper "Modeling of Coplanar Interdigital Capacitor for Microwave Microfluidic Application" for the relationship between IDC capacitance and the permittivity.

Additional Questions:

Please confirm that you have reviewed all relevant files, including supplementary files and any author response files, which can be found in the "View Author's Response" link above (author responses will only appear for resubmissions): Yes, all files have been reviewed

- 1) Does the paper contribute to the body of knowledge?: yes
- 2) Is the paper technically sound?: yes
- 3) Is the subject matter presented in a comprehensive manner?: yes
- 4) Are the references provided applicable and sufficient?: yes
- 5) Are there references that are not appropriate for the topic being discussed?: No
- 5a) If yes, then please indicate which references should be removed.:

If you have any questions, please contact article administrator: Mr. Ankit Srivastava a.srivastava@ieee.org

Powered by **Research Exchange Submission** © Research Exchange

[Privacy Policy](#) | [Cookie Preferences](#) | [Terms](#) | [Help](#)

[IEEE Privacy Policy](#) | [Contact us](#)

Response Letter

Dear Kristin Falco
Senior Journals Production Manager of IEEE

Please find the response letter for our manuscript.

Periodical Title: IEEE Access
Volume: Volume 0
Digital Object Identifier: 10.1109/ACCESS.2025.3538042
Manuscript Number: Access-2025-00351

Please do not hesitate to contact me if there are any questions.

Yours Sincerely,

Syah Alam *et al.*
Department of Electrical Engineering, Universitas Trisakti, West Jakarta 11440, Indonesia
Email: syah.alam@trisakti.ac.id

=====

Title:
“High Stability Single-Port Dual Band Microwave Sensor Based on Interdigital Capacitor Structure with Asymmetry Branch Feedline”

AQ:1 = Please confirm the representation of the author’s name “RADEN DEINY MARDIAN” and “ZHRILADHA ZAKARIA” throughout the article.

Ans:
Thanks for the queries. We agree and confirm that the author’s name is RADEN DEINY MARDIAN and ZHRILADHA ZAKARIA” throughout the article.

AQ:2 = Please confirm whether the edits made in the current affiliation of all the authors are correct.

Ans:
Thanks for the queries. Thanks for the queries. We agree and confirm that the author’s affiliations in added to the final manuscript are correct.

AQ:3 = Please confirm or add details for any funding or financial support for the research of this article

Ans:
Thanks for the queries. We agree and confirm that funding of research is supported by Research and Community Services Institute of Universitas Trisakti and Ministry of Research, Technology and Higher Education of Republik Indonesia through a competitive research grant under the Strategic Research Collaboration Research Scheme fiscal year of 2024 with contract number of 058/E5/PG.02.00/PL.BATCH.2/2024 and 1091/LL3/AL.04/2024.

AQ:4 = Please provide the expansion of the acronym KATALIS for your funding agency. Providing the correct acknowledgment will ensure proper credit to the funder.

Ans:

Thanks for the queries. We agree and confirm that funding of research is supported by Research and Community Services Institute of Universitas Trisakti and Ministry of Research, Technology and Higher Education of Republik Indonesia through a competitive research grant under the Strategic Research Collaboration (KATALIS) Scheme fiscal year of 2024 with contract number of 058/E5/PG.02.00/PL.BATCH.2/2024 and 1091/LL3/AL.04/2024.

Correction:

This work is supported by Research and Community Services Institute of Universitas Trisakti and Ministry of Research, Technology and Higher Education of Republik Indonesia through a competitive research grant under the Strategic Research Collaboration (KATALIS) Scheme fiscal year of 2024 with contract number of 058/E5/PG.02.00/PL.BATCH.2/2024 and 1091/LL3/AL.04/2024.

AQ:5 = If you haven't done so already, please make sure you have submitted a graphical abstract for your paper. The GA should be a current figure or image from your accepted article. The GA will be displayed on your article's abstract page on IEEE Xplore. Please choose a current figure from the paper and supply a caption at your earliest convenience for the graphical abstract. Note that captions cannot exceed 1800 characters (including spaces). If you submitted a video as your graphical abstract, please make sure there is an overlay image and caption. Overlay images are usually a screenshot of your video that best represents the video. This is for readers who may not have access to video-viewing software. Please see an example in the link below: <http://ieeaccess.ieee.org/submitting-an-article/>

Ans:

Thanks for the queries. We have uploaded the graphical abstract including captions along with the final manuscript.

AQ:6 = Please provide better/higher quality image for the authors SYAH ALAM, TEGUH FIRMANSYAH, and MUDRIK ALAYDRUS.

Ans:

Thanks for the correction. We update the following provide better/higher quality image for the authors SYAH ALAM, TEGUH FIRMANSYAH, and MUDRIK ALAYDRUS

Correction:



SYAH ALAM



TEGUH FIRMANSYAH



MUDRIK ALAYDRUS

AQ:7 = Please check and confirm whether the year 1996 provided for the author INDRA SURJATI is correct.

Ans:

Thanks for the queries. We agree and confirm that the year 1996 provided for the author INDRA SURJATI is correct.

Response Letter

Dear Kristin Falco
Senior Journals Production Manager of IEEE

Please find the response letter for our manuscript.

Periodical Title: IEEE Access

Volume: Volume 0

Digital Object Identifier: 10.1109/ACCESS.2025.3538042

Manuscript Number: Access-2025-00351

Early Access : <https://ieeexplore.ieee.org/document/10870129/authors#authors>

Please do not hesitate to contact me if there are any questions.

Yours Sincerely,

Syah Alam *et al.*

Department of Electrical Engineering, Universitas Trisakti, West Jakarta 11440, Indonesia

Email: syah.alam@trisakti.ac.id

=====

Along with this letter, we would like to propose an addition to the acknowledgment in our accepted paper. We propose this because this work also received support from Universiti Teknikal Melaka Malaysia (UTeM) for the contribution of APC payment and also the validation and verification process of the proposed sensor performance. We ask for your cooperation to update the acknowledgment in our paper.

Previous version:

This work is supported by Research and Community Services Institute of Universitas Trisakti and Ministry of Research, Technology and Higher Education of the Republic of Indonesia through a competitive research grant under the Strategic Research Collaboration (KATALIS) Scheme fiscal year of 2024 with contract number of 058/E5/PG.02.00/PL.BATCH.2/2024 and 1091/LL3/AL.04/2024.

Revised version:

This work is supported by the Research and Community Services Institute of Trisakti University and Ministry of Research, Technology and Higher Education of the Republic of Indonesia through a competitive research grant under the Strategic Research Collaboration (KATALIS) Scheme fiscal year of 2024 with contract number of 058/E5/PG.02.00/PL.BATCH.2/2024 and 1091/LL3/AL.04/2024. Additionally, this research is also supported by the collaboration between Trisakti University and Universiti Teknikal Malaysia Melaka (UTeM)

RESEARCH ARTICLE

High Stability Single-Port Dual Band Microwave Sensor Based on Interdigital Capacitor Structure With Asymmetry Branch Feedline

SYAH ALAM¹, (Member, IEEE), INDRA SURJATI¹, (Member, IEEE), LYDIA SARI¹, (Member, IEEE), RADEN DEINY MARDIAN¹, (Member, IEEE), TEGUH FIRMANSYAH², (Member, IEEE), MUHAMMAD IQBAL³, SLAMET WIDODO⁴, MUDRIK ALAYDRUS⁵, (Senior Member, IEEE), AND ZAHRIADHA ZAKARIA⁶, (Senior Member, IEEE)

¹Department of Electrical Engineering, Universitas Trisakti, West Jakarta 11440, Indonesia

²Department of Electrical Engineering, Universitas Sultan Ageng Tirtayasa, Serang, Banten 42124, Indonesia

³Advanced Functional Materials Laboratory, Faculty of Industrial Technology, Institut Teknologi Bandung, Bandung 40132, Indonesia

⁴Department of Mechanical and Biosystems Engineering, IPB University, Bogor 16680, Indonesia

⁵Department of Electrical Engineering, Universitas Mercu Buana, West Jakarta 11650, Indonesia

⁶Faculty of Electronic and Computer Technology and Engineering, Universiti Teknikal Malaysia Melaka (UTeM), Durian Tunggal 76100, Malaysia

Corresponding authors: Syah Alam (syah.alam@trisakti.ac.id) and Zahriladha Zakaria (zahriladha@utem.edu.my)

This work is supported by the Research and Community Services Institute of Trisakti University and Ministry of Research, Technology and Higher Education of the Republic of Indonesia through a competitive research grant under the Strategic Research Collaboration (KATALIS) Scheme fiscal year of 2024 with contract number of 058/E5/PG.02.00/PL.BATCH.2/2024 and 1091/LL3/AL.04/2024. Additionally, this research is also supported by the collaboration between Trisakti University and Universiti Teknikal Malaysia Melaka (UTeM).

ABSTRACT This paper proposes a single-port interdigital capacitor (IDC) resonator based on asymmetric branch feed line with high stability performance for permittivity detection of solid materials with a permittivity range of 1 - 6.15. The microwave sensor is designed using a single-port resonator operating at two different resonant frequencies $f_{r1} = 1.61$ GHz and $f_{r2} = 2.52$ GHz. Dual band frequency was proposed using asymmetric branch feed line. In addition, to confine the electric field concentration of the resonator, an interdigital capacitor (IDC) structure is proposed as a solution. Furthermore, a copper shield was proposed as conducting material to evaluate performance stability of the sensor from disturbance effect with range of $d = 1$ cm - 2.5 cm. Based on the measurement results, the sensor has high stability both without and with disturbance with an a Frequency Detection Resolution (FDR) of 0.009 - 0.4 GHz/ $\Delta\epsilon_r$, a Normalized Sensitivity (NS) of 0.4% - 4.4%, and an average accuracy of 90% - 95% for both resonance frequencies, respectively. Therefore, this sensor can be recommended for several applications such as biomedical industry, pharmaceuticals and material quality control especially for outdoor measurements that are potentially affected by electromagnetic interference and disturbance.

INDEX TERMS Dual-band, high stability, interdigital capacitor, microwave sensor, single-port resonator.

I. INTRODUCTION

Microwave sensors (MS) have seen significant advancement in the evaluation of both solids and liquids due to their advantages, such as high precision, a high Q-factor, cost-effectiveness, and compactness [1], [2], [3]. One of the measurable properties using MS is permittivity, which reflects a material's ability to sustain an electric field. The permittivity of the material under test (MUT) can be determined

The associate editor coordinating the review of this manuscript and approving it for publication was Wen-Sheng Zhao¹.

via perturbation theory, assuming the MUT behaves as a capacitive load [4], [5], [6]. Several microwave sensors based on resonators like the Split Ring Resonator (SRR) [7], [8], [9], [10], Complementary Split Ring Resonator (CSRR) [11], [12], [13], Substrate Integrated Waveguide (SIW) [14], [15], Interdigital Capacitor (IDC) [16], [17], [18], [19], [20], [21], AMC [22], [23] have been developed for solid and liquid material assessment.

Previous work presented a single-port MS based on slot loaded [24] and dual U-shaped [25] for solid material characterization. Furthermore, another work proposed a

dual-function permittivity sensor with an antenna using a single-port resonator for solid material characterization using an aperture coupling structure [26]. In addition, previous work [27] proposed a single-port microwave sensor based on dual T-shaped for contact and long-distance detection. The advantage of a single-port resonator-based microwave sensor is that it can also function as an antenna for data transmission [28]. However, the performance of a single-port resonator-based microwave sensor has a high potential to be inferred by electromagnetic waves and is also susceptible to disturbance. This is because the single-port resonator also transmits electromagnetic waves so that it is more susceptible to environmental disturbances, for example conducting materials. In addition, another limitation is that there is a higher likelihood of interference between the input and reflected signals. This can lead to difficulties and instability in the accuracy of representing measurement data. Therefore, a single-port resonator-based microwave sensor with high stability is needed to obtain accurate and reliable measurement results.

This work provides an excellent solution by proposing a high stability single-port MS based on Interdigital Capacitor (IDC) structure. The MS is designed to operate at two different frequencies $f_{r1} = 1.61$ GHz and $f_{r2} = 2.52$ GHz using an asymmetric branch feed line while the IDC structure is used to confine the concentration of the E-field in the sensing area so that the sensor is more focused on detecting samples. Furthermore, to observe the performance stability of the proposed sensor, a rectangular copper shield as conducting material is placed right above the sensor surface with a distance range of $d = 1$ cm - 2.5 cm to emulate as a disturbance. The performance of the sensor observed in this work is related to frequency shift, ΔF , Frequency Detection Resolution (FDR), Normalized Sensitivity (NS) and average accuracy. In addition, an interdigital capacitor structure also can minimize the H-field distribution so that the highest E-field concentration is focused on the sensing area of the proposed sensor. From the measurement results, the proposed sensor has high stability both without and with disturbance for a distance range of $d = 1 - 2.5$ cm. The sensor has stable performance with a frequency detection resolution of $0.009 - 0.4$ GHz/ $\Delta\epsilon_r$, a normalized sensitivity of 0.4% - 4.4%, and an average accuracy of 90% - 95% for both resonance frequencies, respectively.

II. WORKING PRINCIPLE OF PROPOSED SENSOR

This section explains the structure, equivalent circuit and sensing area location determination of the IDC resonator using asymmetric branch feedline.

A. DEVELOPMENT MODEL OF PROPOSED RESONATOR

Furthermore, to estimate the performance of the resonator having dual band characteristics, a development model of the proposed resonator was represented as shown in Fig. 1. The 1st model of the resonator is represented by a T-shaped resonator operating at a single band at a frequency of 2.26 GHz.

Furthermore, the 2nd model is represented by a T-shaped connected with two open-ended inductive arms that function as branch lines that generate a single band resonant frequency of 1.16 GHz. The resonant frequency of the resonator moves to a lower frequency in line with the increase in the arm length of the resonator. In the 3rd model, the IDC structure is connected with two open-ended inductive arms of the resonator that produce dual-band characteristics with $f_{r1} = 1.62$ GHz and $f_{r2} = 2.42$ GHz.

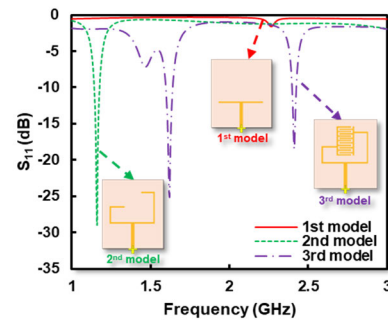

FIGURE 1. Development model of proposed resonator, (a) 1st model, (b) 2nd model, (c) 3rd model.

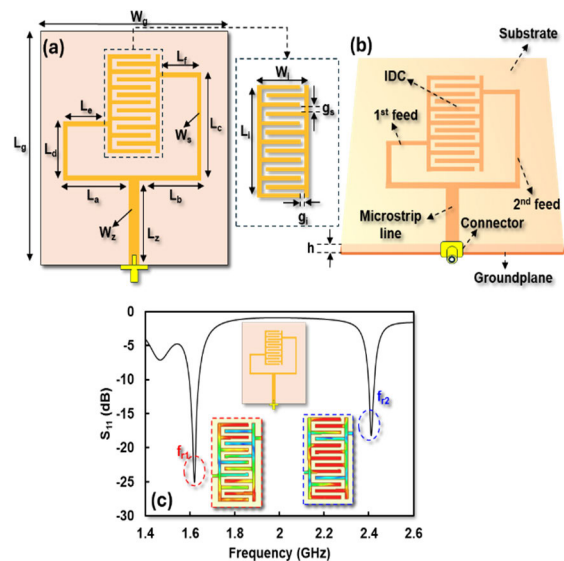

FIGURE 2. Model of the microwave sensor; (a) dimensions of the microwave sensor, (b) structure of the microwave sensor, (c) simulation of the reflection coefficient of the microwave sensor.

B. STRUCTURE OF PROPOSED IDC RESONATOR USING ASYMMETRY BRANCH FEED LINE

The proposed microwave sensor is designed using FR-4 substrate type with dielectric constant (ϵ_r) 4.3, loss tan ($\tan \alpha$) 0.0265 and thickness (h) 1.6 mm. The microwave sensor is designed using a single-port resonator operating at two different resonant frequencies $f_{r1} = 1.62$ GHz and $f_{r2} = 2.42$ GHz. To produce dual frequencies, the resonator is connected with RP-SMA connector with impedance of 50Ω using dual-feed approach.

In addition, to increase the electric field concentration of the resonator, interdigital capacitor (IDC) structure is proposed as a solution. **Fig. 2 (a)** shows the dimensions of the proposed sensor. Furthermore, **Fig. 2 (b)** shows the structure of the proposed sensor where the sensor is designed using a PCB with two copper layers while the upper layer of the PCB is used to place the sensor made of copper and the lower layer is used as a ground plane. The simulation results of the proposed sensor are shown in **Fig. 2 (c)** where the sensor operates at two different resonant frequencies, namely $f_{r1} = 1.62$ GHz and $f_{r2} = 2.42$ GHz.

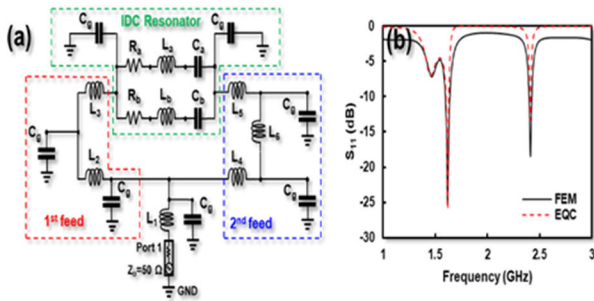

FIGURE 3. Modeling of the proposed sensor; (a) Equivalent circuit of the proposed sensor, (b) comparison of simulation results from FEM and EQC.

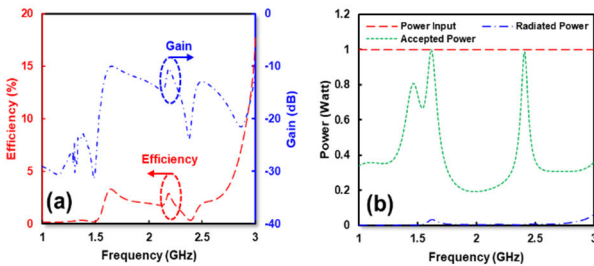

FIGURE 4. Simulation result of single port resonator, (a) efficiency and gain of proposed resonator, (b) comparison between input, accepted and radiated power of proposed resonator.

The dimensions of the proposed sensor are represented by $W_g = 50$ mm, $L_g = 50$ mm, $W_s = 3.1$ mm, $L_z = 15$ mm, $L_a = 17.3$ mm, $L_b = 15.9$ mm, $W_s = 1$ mm, $L_c = 26.7$ mm, $L_d = 13.7$ mm, $L_e = 11.8$ mm and $L_f = 11.8$ mm. Furthermore, the dimensions of the IDC structure are represented by $W_i = 11.7$ mm and $L_i = 25$ mm while the gaps in each IDC are represented by $G_i = G_s = 1$ mm. It should be noted that the width and length of the gap greatly affect the electric field concentration and the resonant frequency of the proposed sensor.

The performance in terms of gain and efficiency of the single port resonator are shown in **Fig. 4(a)** and **Fig. 4(b)**. Furthermore, **Fig. 4(a)** shows that the proposed resonator has low efficiency at $f_{r1} = 1.61$ GHz and $f_{r2} = 2.42$ GHz of 3.04% and 0.68%, respectively. In addition, the gain of proposed resonator is also very low where for $f_{r1} = 1.62$ GHz and $f_{r2} = 2.42$ GHz it is -10.37 dB and -16.63 dB, respectively.

Furthermore, the ratio between the input power, received power and transmitted power of the proposed resonator is also very low as shown in **Fig. 4 (b)**. From the simulation results, the default input power is 1 watt while the transmitted power for $f_{r1} = 1.62$ GHz and $f_{r2} = 2.42$ GHz is 0.98 watt and 0.97 watt. However, the transmitted power is very low where for $f_{r1} = 1.62$ GHz and $f_{r2} = 2.42$ GHz is 0.03 watt and 0.006 watt, respectively. Furthermore, the radiation pattern of the proposed resonator is shown in **Fig. 5 (a)** and **Fig. 5 (b)** where $f_{r1} = 1.62$ GHz and $f_{r2} = 2.42$ GHz have a maximum gain of -10.38 dB and -17.02 dB. This finding indicates that the proposed resonator has low performance to function as an antenna due to low efficiency and gain. Thus, this structure is more suitable for microwave sensors.

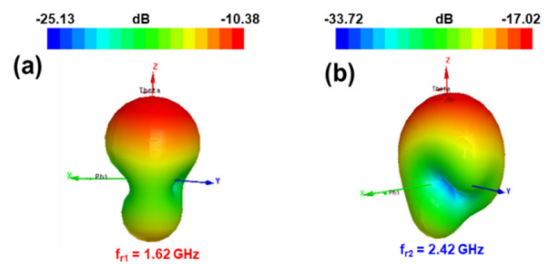

FIGURE 5. Simulation result of radiation pattern, (a) radiation pattern at $f_{r1} = 1.62$ GHz, (b) radiation pattern at $f_{r2} = 2.42$ GHz.

C. EQUIVALENT CIRCUIT MODEL OF PROPOSED RESONATOR

Next, the proposed sensor can be modeled using an equivalent circuit (EQC) based on resistor (R), capacitor (C) and inductor (L) [29] as shown in **Fig. 3 (a)**. The equivalent circuit of the proposed sensor is calculated and simulated using AWR 2009 and compared with Finite Element Modeling (FEM) as shown in **Fig. 3 (b)**. Based on the equivalent circuit shown in **Fig. 3 (a)**, the feedline of the resonator is represented by $L_1 = 14$ nH which is connected to port 1 with an impedance of $Z_0 = 50\Omega$. In this work, the asymmetric branch feedline is represented by $L_2 = 15.3$ nH and $L_3 = 0.71$ nH as the 1st arm while the 2nd arm is represented by $L_4 = 0.000242$ nH, $L_5 = 20.89$ nH and $L_6 = 9.18$ nH. In addition, the IDC resonator is represented by two resonators with series configuration connected in parallel where $R_a = 0.027$ k Ω , $L_a = 41.97$ nH, $C_a = 805$ pF while for $R_b = 2.46$ k Ω , $L_b = 0.262$ nH and $C_b = 6.28$ pF. To prevent short circuits, $C_g = 1$ pF is proposed as grounding. Overall, the resonant frequency of the resonator can be determined using the following equation [28]:

$$f_r = \frac{1}{2\pi\sqrt{LC}} \quad (1)$$

Fig. 3 (b) shows that the simulation results of EQC and FEM have identical characteristics where the resonator operates in dual band with $f_{r1} = 1.62$ GHz and $f_{r2} = 2.42$ GHz. This finding indicates that the proposed equivalent circuit

model has represented the working principle of the proposed resonator.

D. SENSING AREA DETERMINATION

In this work, the sensor is designed to detect the permittivity of the sample by observing the interaction between the electric field and the permittivity of the sample used. The resonator surface that has a high electric field (E-field) can be recommended as the sensing area used to place the sample. The sample used is a dielectric sample that does not contain metal. Furthermore, the electric field and magnetic field concentrations of the IDC-based resonator are shown in **Fig.6 (a)**, **Fig.6 (b)**, **Fig.6 (c)** and **Fig.6 (d)**.

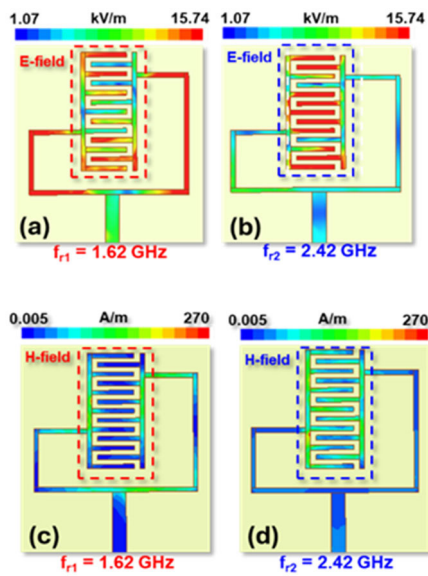

FIGURE 6. E-field and H-field simulations; (a) E-field at $f_{r1} = 1.62$ GHz, (b) E-field at $f_{r2} = 2.41$ GHz, (c) H-field at $f_{r1} = 1.62$ GHz, (d) H-field at $f_{r2} = 2.42$ GHz.

Furthermore, **Fig. 6 (a)** and **Fig. 6 (b)** show that the highest electric field concentration of the proposed resonator at $f_{r1} = 1.62$ GHz and $f_{r2} = 2.42$ GHz is on the IDC surface of the proposed sensor with a range of 1.07 – 15.74 kV/m. In contrast, the magnetic field concentration of the proposed resonator at $f_{r1} = 1.62$ GHz and $f_{r2} = 2.42$ GHz are very low and is in the range of 0.005 – 270 A/m as shown in **Fig. 6 (c)** and **Fig. 6 (d)**. These findings indicate that the IDC surface has a high electric field and a low magnetic field so that it becomes a potential location as a sensing area that can be recommended to place samples to be detected. It also shows that the application of the IDC structure has successfully confined the electric field and reduced the magnetic field in the proposed sensor.

Moreover, **Fig. 7 (a)** shows the scenario of dielectric sample placement on the proposed sensor. In this work, the dielectric sample is placed in the sensing area determined based on the highest E-field concentration with dimensions of 10.7 mm x 23 mm x 1 mm. The samples used consist

of four types of dielectrics with different permittivity where RO5880 is 2.2, RO4003C is 3.65, FR4 is 4.3 and RO3006 is 6.15. The proposed sensor is connected to a Vector Network Analyzer (VNA) and a PC using a coaxial cable and a USB cable with a frequency range of 1 - 3 GHz and a span of 0.001 GHz. The frequency response of f_{r1} and f_{r2} based on the permittivity change of the dielectric sample is shown in **Fig. 7 (b)**. Overall, the resonant frequencies of $f_{r1} = 1.62$ GHz and $f_{r2} = 2.42$ GHz shift to low frequencies in line with the increase of the permittivity of the sample. Based on the simulation results, f_{r1} shifts from 1.64 GHz to 1.63 GHz while for f_{r2} it shifts from 2.42 GHz to 2.02 GHz for the permittivity range of 1 - 6.15. Furthermore, the ΔF of f_{r1} and f_{r2} are shown in **Fig. 7(c)** where for f_{r1} and f_{r2} are 0.01 GHz and 0.4 GHz, respectively.

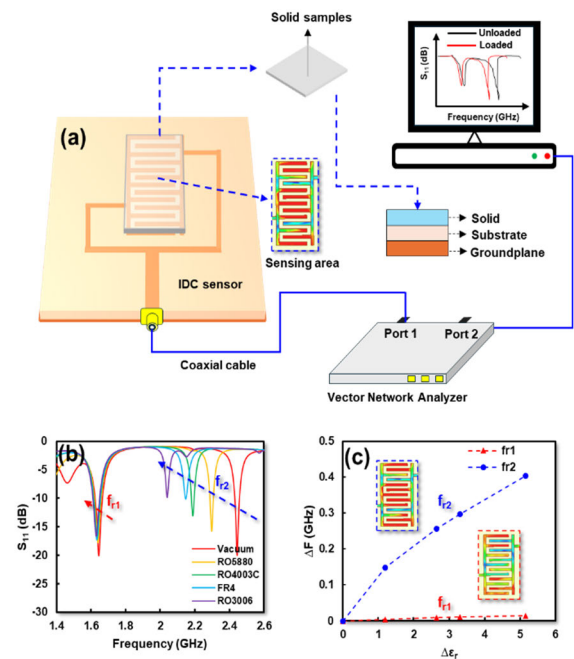

FIGURE 7. (a) Scenario of sample placement of proposed sensor, (b) simulation result of resonance frequency f_{r1} and f_{r2} with permittivity changes, (c) ΔF of proposed sensor for f_{r1} and f_{r2} .

These findings indicate that the proposed sensor can sense the permittivity change of the dielectric sample based on the frequency change. The resonant frequency of the resonator moves toward the low frequency in line with the increase in the permittivity of the dielectric sample. In addition, f_{r2} is more sensitive than f_{r1} because it has a higher frequency [2] and has a higher electric field concentration compared to f_{r1} as shown in **Fig. 7 (c)**.

III. MEASUREMENT RESULT AND VERIFICATION

This section will discuss the measurement and validation of the proposed sensor, the performance and response of the proposed sensor based on the analysis of the disturbance effects. In this work, the proposed sensor is given a rectangular copper shield disturbance placed on the surface of the sensor.

A. MEASUREMENT OF PROPOSED SENSOR

The next stage is to validate the performance of the proposed sensor to characterize solid materials. In this work, the samples used are solid materials whose permittivity has been known based on the datasheet with a range of 1 - 6.15. Solid materials used as samples include RO5880 with a permittivity of 2.2, RO4003C with a permittivity of 3.65, FR4 with a permittivity of 4.3 and RO3006 with a permittivity of 6.15. The dimensions of the samples used are adjusted to the location of the sensing area of the proposed sensor, which is 12.7 mm x 25 mm with a sample thickness of 1.6 mm. The measurement scenario and placement of solid samples on the proposed sensor are shown in Fig. 8. In this work, the solid sample with dimensions of 10.7 mm x 23 mm x 1.6 mm is placed carefully on the sensing area surface protected by a rectangular copper shield with dimensions of 50 × 50 mm x 1.58 mm. The copper shield is placed using a brass spacer placed at a certain distance represented by d . It should be noted that the copper shield is proposed as disturbance and also focuses on the electric field so that it is fully concentrated on the sample. The measurement process of the sensor is carried out in the laboratory using a VNA measuring instrument connected to the sensor using a coaxial cable via port 1 while the reading of the measurement results is carried out using a PC connected to the VNA via a USB cable. The measurement process is carried out in a closed room with an ambient temperature of 25 °C as shown in Fig. 9 (a). Next, a comparison of the simulation and measurement results of the proposed sensor is shown in Fig. 9 (b). From the measurement results shown in Fig. 9 (b), f_{r1} shifts from 1.62 GHz to 1.61 GHz while f_{r2} shifts from 2.42 GHz to 2.52 GHz. These findings indicate that the proposed sensor has identical performance between simulation and measurement with error rates of 0.6% and 4.1% for f_{r1} and f_{r2} , respectively.

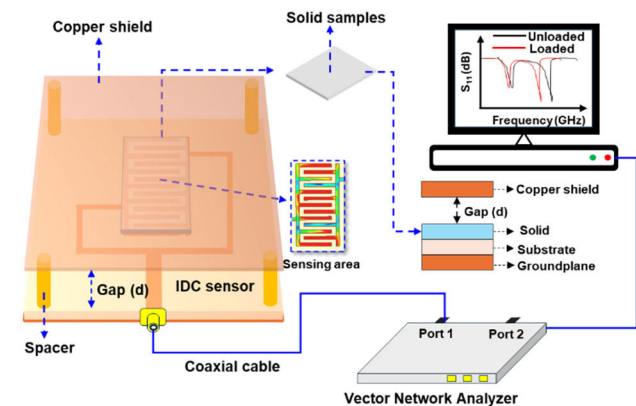

FIGURE 8. Scenario of placing a solid sample on the proposed sensor with copper shield.

Moreover, the measurement setup of the sensor with a copper shield with a distance of $d = 1 - 2.5$ cm is shown in Fig. 9 (c). Based on measurement results, the resonant frequencies of f_{r1} and f_{r2} are fixed and not affected by the copper

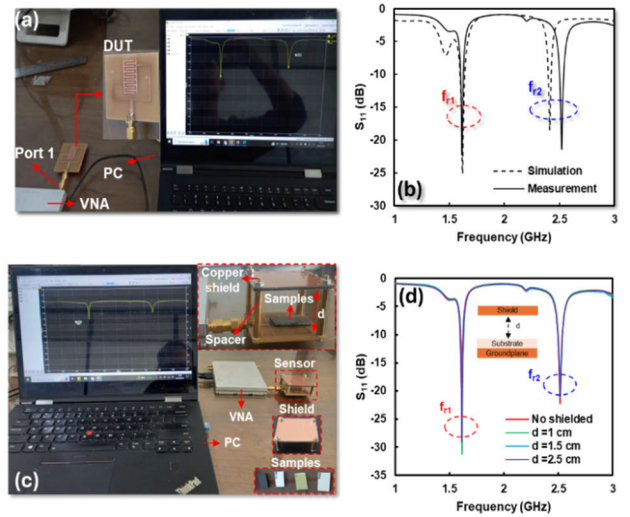

FIGURE 9. Measurement of the proposed sensor; (a) measurement setup, (b) comparison of simulation and measurement, (c) measurement setup of proposed sensor with copper shield, (d) measurement result from proposed sensor with and without shield.

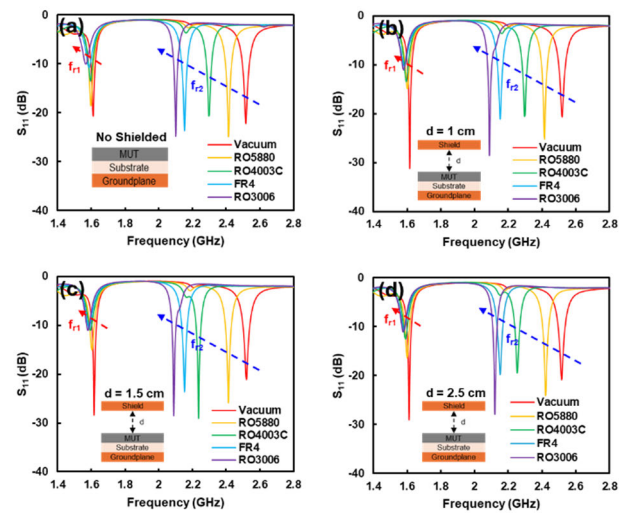

FIGURE 10. Shift of resonance frequency of proposed sensor; (a) without shielded, (b) with cooper shielded of $d = 1$ cm, (c) with cooper shielded of $d = 1.5$ cm, (d) with cooper shielded of $d = 2.5$ cm.

shield placed right above the proposed sensor as shown in Fig. 9 (d).

B. PERFORMANCE OF PROPOSED SENSOR WITH ANALYSIS DISTURBANCE EFFECT

In this work, disturbance in the form of rectangular copper shield is placed above the sensor with a distance range of $d = 1 - 2.5$ cm. The performance of the sensor is observed based on the shift in resonance frequency based on the permittivity of the dielectric sample placed in the sensing area. Furthermore, the four solid material samples are placed right above the sensing area surface of the sensing area where the

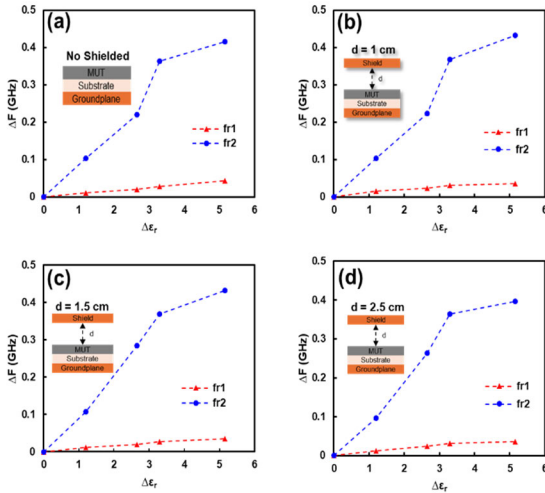

FIGURE 11. ΔF of proposed sensor; (a) without shielded, (b) with copper shielded of $d = 1$ cm, (c) with copper shielded of $d = 1.5$ cm, (d) with copper shielded of $d = 2.5$ cm.

sensor condition without sample (vacuum) with ε_r of 1 is used as a reference. In addition, the effects of disturbance are also observed separately when the sensor is without copper shield and using copper shield with a distance of $d = 1$ cm - 2.5 cm as shown in **Fig. 10 (a)**, **Fig. 10 (b)**, **Fig. 10 (c)** and **Fig. 10 (d)**. Furthermore, the frequency shift of the sensor (ΔF), normalized sensitivity and frequency detection resolution (FDR) which is determined based on the following equation [30] [31]:

$$\Delta f = (f_{\text{unloaded}} - f_{\text{loaded}}) \text{GHz} \quad (2)$$

$$NS = \frac{1}{\Delta \varepsilon_r} \left(\frac{f_{\text{unloaded}} - f_{\text{loaded}}}{f_{\text{unloaded}}} \right) \% \quad (3)$$

$$FDR = \frac{\Delta F}{\Delta \varepsilon_r} \text{GHz} \quad (4)$$

where ΔF represents the frequency shift range, f_{unloaded} is the resonance frequency when the sensor is in a vacuum condition while f_{loaded} is the frequency of the sensor when the sample is loaded, NS is the normalized sensitivity and $\Delta \varepsilon_r$ is the difference between the permittivity of the reference sample and the permittivity of the sample loaded to the sensor.

Furthermore, the correlation between the resonant frequency and permittivity changes of the four dielectric samples for shielded condition is shown in **Fig.10 (a)** where f_{r1} shifts from 1.62 GHz to 1.56 GHz while for f_{r2} shifts from 2.52 GHz to 2.1 GHz for the permittivity range of 1 - 6.15. Furthermore, the performance of the sensor with copper shielding for $d = 1$ cm and $d = 1.5$ cm is shown in **Fig. 10 (b)** and **Fig. 10 (c)** where f_{r1} shifts from 1.61 GHz to 1.58 GHz while for f_{r2} from 2.52 GHz to 2.02 GHz, respectively. In line with the previous, f_{r1} shifts from 1.61 GHz to 1.58 GHz and f_{r2} from 2.52 to 2.12 GHz for $d = 2.5$ cm as shown in **Fig. 10 (d)**. The resonant frequency shift of the sensor is represented as ΔF which can be determined using

Eq. (2). Furthermore, ΔF of the proposed sensor is shown in **Fig. 11(a)**, **Fig. 11(b)**, **Fig. 11(c)** and **Fig. 11(d)**.

From the measurement results, the maximum ΔF of the proposed sensor has a stable performance where for f_{r1} is 0.03 GHz and f_{r2} is 0.4 GHz for conditions with or without copper shielding. In addition, the same findings for the Frequency Detection Resolution (FDR) of the proposed sensor which can be determined using Eq. (4) where for the maximum FDR for f_{r1} is 0.009 GHz / $\Delta \varepsilon_r$ while for f_{r2} is 0.11 GHz / $\Delta \varepsilon_r$ for both conditions with or without shielding as shown in **Fig. 12(a)**, **Fig. 12(b)**, **Fig. 12(c)** and **Fig. 12(d)**.

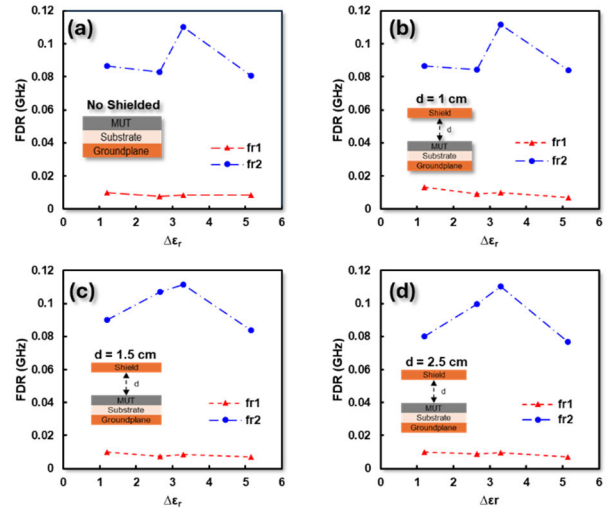

FIGURE 12. Frequency detection resolution of proposed sensor; (a) without shielded, (b) with copper shielded of $d = 1$ cm, (c) with copper shielded of $d = 1.5$ cm, (d) with copper shielded of $d = 2.5$ cm.

These findings indicate that the performance of the proposed sensor is not significantly affected by the addition of disturbance in the form of a copper shield. ΔF and FDR of the proposed sensor are relatively stable to detect the permittivity of dielectric samples with a permittivity range of 1 - 6.15.

The normalized sensitivity (NS) of the proposed sensor can be determined based on Eq. (3). Furthermore, the NS of the proposed sensor for conditions with or without copper shield are shown in **Fig. 13 (a)**, **Fig. 13 (b)**, **Fig. 13 (c)** and **Fig. 13 (d)**. Based on the measurement results, the NS for the sensor with the condition without copper shield is in the range of 0.53% - 0.62% for f_{r1} while for f_{r2} it is in the range of 3.21% - 4.38% as shown in **Fig. 13(a)**. Furthermore, the NS for the sensor condition with copper shield for $d = 1$ cm is in the range of 0.43% - 0.83 for f_{r1} and f_{r2} in the range of 3.33 - 4.43% as shown in **Fig. 13 (b)**. In addition, the NS for the sensor with copper shield condition for $d = 1.5$ cm is in the range of 0.43% - 0.62% for f_{r1} while for f_{r2} is in the range of 3.33% - 4.43% as shown in **Fig. 13 (c)**. Finally, the NS for the sensor with copper shield for $d = 2.5$ cm is presented by **Fig. 13 (d)** where f_{r1} is in the range of 0.43% - 0.62% while for f_{r2} is in the range of 3.06% - 4.38%.

This finding indicates that the NS of the sensor with copper and without shield is stable because the electric field is more concentrated in the sensing area of the proposed sensor. This finding is also in line with the simulation where the E-field concentration of the IDC-based sensor is more dominant compared to the H-field so that the electric field from the sensor is focused in the sensing area of the sensor. In addition, the NS of the sensor without and with copper shield for the range $d = 1\text{ cm} - 2.5\text{ cm}$ has a stable performance in the range of 0.4% - 0.8% and 3% - 4% for f_{r1} and f_{r2} , respectively.

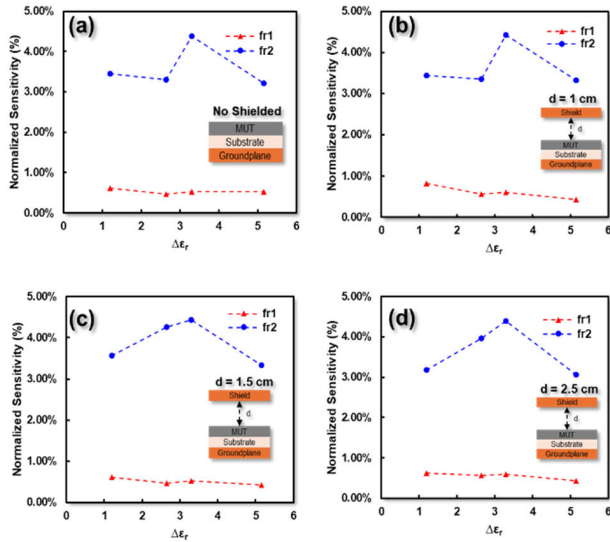

FIGURE 13. Normalized sensitivity of proposed sensor; (a) without shielded, (b) with copper shielded of $d = 1\text{ cm}$, (c) with copper shielded of $d = 1.5\text{ cm}$, (d) with copper shielded of $d = 2.5\text{ cm}$.

This finding also shows that the addition of copper shield with a range of $d = 1\text{ cm} - 2.5\text{ cm}$ as a disturbance has no significant effect on the performance of the proposed sensor and can be used to confined the electric field of the proposed sensor in the specific sensing area.

C. ACCURACY OF PROPOSED SENSOR

Furthermore, the correlation between resonance frequency and permittivity can be derived into a third-order polynomial equation that can be used to determine the permittivity of solid materials [32], [33], [34] as shown in Fig.14 (a), Fig. 14(b), Fig. 14(c), Fig. 14(d), Fig. 14(e), Fig. 14(f), Fig. 14(g) and Fig. 14(h). Based on the correlation between the resonant frequency and permittivity from the measurement result, the permittivity of the dielectric sample for the condition without copper shielding can be determined based on the third-order polynomial equation as follows:

$$\varepsilon_{r1} = a_1 f_{r1}^3 + a_2 f_{r1}^2 - a_3 f_{r1} + a_4 \quad (5)$$

$$\varepsilon_{r2} = b_1 f_{r2}^3 + b_2 f_{r2}^2 - b_3 f_{r2} + b_4 \quad (6)$$

where ε_{r1} is the permittivity of the sample based on f_{r1} and ε_{r2} is the permittivity based on f_{r2} . Furthermore, based on the third order polynomial equation, the values of $a_1 = -78.685$,

$a_2 = 174.14$, $a_3 = 75667$, $a_4 = 0$, $b_1 = -156.76$, $b_2 = 1091.2$, $b_3 = 2537$ and $b_4 = 1973.3$ are obtained for conditions without copper shield as shown in Fig. 14 (a) and Fig. 14 (b). Next, for $d = 1\text{ cm}$ the values are obtained from $a_1 = -143572$, $a_2 = 691050$, $a_3 = 1\text{E}+06$, $a_4 = 593083$, $b_1 = -133.95$, $b_2 = 930.72$, $b_3 = 2161.1$ and $b_4 = 1680$ while for $d = 1.5\text{ cm}$ the values are obtained from $a_1 = -54026$, $a_2 = 260387$, $a_3 = 418443$, $a_4 = 224209$, $b_1 = -125.03$, $b_2 = 876.5$, $b_3 = 2053.8$ and $b_4 = 1611.1$ as shown in Fig. 14 (c), Fig. 14 (d), Fig. 14 (e), Fig. 14 (f). Finally, for the condition $d = 2.5\text{ cm}$ the values are obtained from $a_1 = -19381$, $a_2 = 928985$, $a_3 = -1\text{E}+06$, $a_4 = 790597$, $b_1 = -188.7$, $b_2 = 1323.7$, $b_3 = -3100$ and $b_4 = 2426.3$ as shown in Fig. 14 (g) and Fig. 14 (h). Overall, the permittivity based on calculations for f_{r1} and f_{r2} is shown in Table 1 and Table 2.

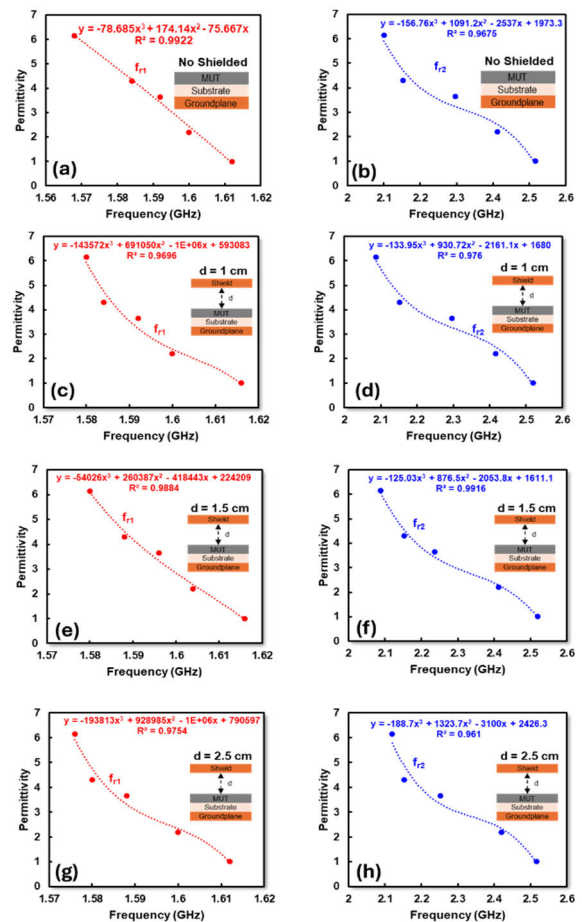
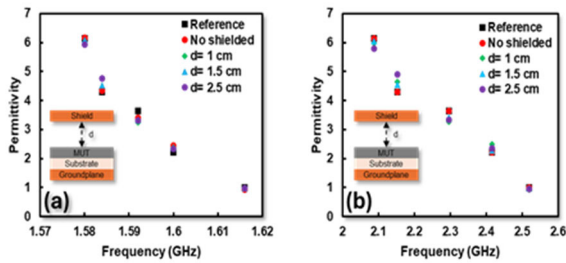

FIGURE 14. Polynomial equation based on resonant frequency and permittivity; (a) without shielded for f_{r1} , (b) without shielded for f_{r2} , (c) with copper shielded of $d = 1\text{ cm}$ for f_{r1} , (d) with copper shielded of $d = 1\text{ cm}$ for f_{r2} , (e) with copper shielded of $d = 1.5\text{ cm}$ for f_{r1} , (f) with copper shielded of $d = 1.5\text{ cm}$ for f_{r2} , (g) with copper shielded of $d = 2.5\text{ cm}$ for f_{r1} , (h) with copper shielded of $d = 2.5\text{ cm}$ for f_{r2} .

Based on Table 1 and Table 2, the proposed sensor has good average accuracy where for the condition without copper shield it is at 94.96% and 90.48% for f_{r1} and f_{r2} , respectively. Furthermore, the average accuracy for f_{r1} and

TABLE 1. Accuracy Of proposed sensor for 1st resonant frequency.

ϵ_r reference	No shielded		Shielded cooper					
	ϵ_r calc.	Acc. (%)	$d = 1$ cm		$d = 1.5$ cm		$d = 2.5$ cm	
			ϵ_r calc.	Acc. (%)	ϵ_r calc.	Acc. (%)	ϵ_r calc.	Acc. (%)
1	0.94	93.54	0.98	98.25	0.97	97.36	0.97	97.20
2.2	2.44	89.21	2.39	91.51	2.37	92.13	2.33	93.92
3.65	3.41	93.32	3.23	88.61	3.34	91.46	3.32	90.84
4.3	4.35	98.86	4.77	89.14	4.52	94.82	4.75	89.50
6.15	6.16	99.86	5.93	96.39	6.09	99.06	5.93	96.37

**FIGURE 15.** Accuracy of proposed sensor; (a) without shielded, (b) with cooper shielded of $d = 1$ cm, (c) with cooper shielded of $d = 1.5$ cm, (d) with cooper shielded of $d = 2.5$ cm.**TABLE 2.** Accuracy Of Proposed Sensor For 2nd resonant frequency.

ϵ_r reference	No shielded		Shielded cooper					
	ϵ_r calc.	Acc. (%)	$d = 1$ cm		$d = 1.5$ cm		$d = 2.5$ cm	
			ϵ_r calc.	Acc. (%)	ϵ_r calc.	Acc. (%)	ϵ_r calc.	Acc. (%)
1	0.91	91.39	0.92	91.73	0.97	97.26	0.95	94.94
2.2	2.51	86.00	2.48	87.11	2.28	96.21	2.34	93.52
3.65	3.23	88.58	3.27	89.57	3.44	94.11	3.33	91.35
4.3	4.72	90.12	4.64	92.04	4.56	93.96	4.89	86.24
6.15	5.92	96.31	5.99	97.36	6.05	98.36	5.78	94.01

f_{r2} for the sensor with copper shield is 92.78% and 91.72% for $d = 1$ cm and for $d = 1.5$ cm the average accuracy is 94.97% and 95.98% while for $d = 2.5$ cm, the average accuracy is at 93.57% and 92.01%, respectively.

This finding shows that the best average accuracy is obtained when $d = 1.5$ cm. In addition, the sensor has a consistent average accuracy for conditions with and without shield. In addition, the sensor has a consistent average accuracy for conditions with and without shield compared with reference permittivity as shown in Fig. 15 (a) and Fig. 15 (b). This finding also shows that the proposed sensor has high performance and is not significantly affected by disturbances placed directly above the sensor with range of $d = 1$ cm – 2.5 cm.

IV. VALIDATION WITH PREVIOUS WORKS

A thorough evaluation comparing the proposed sensor's performance with previous studies is conducted, as detailed in

Table 3. A fair comparison with previous work is proposed by observing the performance of the sensor in terms of the method, permittivity range, resonance frequency (f_r), Frequency Detection Resolution (FDR), Normalized Sensitivity (NS) and accuracy. In addition, other performances that are compared are dual band characteristics, e-field localization, disturbance effect analysis and also high stability of the proposed sensor.

Previous work proposed a microwave sensor using a dual-port resonator for permittivity detection of solid materials based on SRR [8], [10], [33], IDC structure [19], [20] and CSRR [13]. The sensor has good performance with a maximum accuracy of 96% - 98% and a normalized sensitivity of 1.34% - 5.38%. However, the proposed sensor only supports transmission mode-based measurements and requires a two-port network analyzer for characterization, which can increase the complexity and cost of the measurement setup.

Previous studies introduced a single-port resonator incorporating a slot for permittivity detection of dielectric samples, achieving an accuracy of 98.80% and a normalized sensitivity of 5.24% [24]. However, the sensor's electric field remains inadequately localized and focused on the sensing area, potentially leading to measurement inaccuracies in the presence of interference or disturbances. In addition, the proposed sensor only operates at a single resonant frequency. Moreover, a single-port microwave sensor with dual band performance utilizing U-shaped [25] and T-shaped resonators [27] was proposed in another study, featuring independent characteristics for simultaneous detection of solid material permittivity and long-distance sensing. The electric field of the resonator was localized on its arm, designated as the sensing area. However, the study did not include an analysis of disturbance effects, leaving the stability of the proposed sensor under disturbed conditions unverified.

Previous work introduced a single-port microwave sensor employing aperture coupling [26] and an artificial magnetic conductor [22]. The electric field was localized on a separate substrate, designated as the sensor's sensing area. However, the proposed structure features a multilayer design, making it more complex to implement. Furthermore, the study did not include an analysis of disturbance effects, leaving the sensor's stability under such conditions unverified. This work provides an excellent solution to produce a microwave sensor using a single-port resonator that has high stability against disturbances. In this work, an interdigital capacitor structure is introduced to confine the E-field of the sensor to focus it on the sensing area of the sensor. In addition, the interdigital capacitor structure also reduces the H-field so that the E-field becomes more dominant. The stability of the sensor is evaluated and confirmed by placing a disturbance in the form of a rectangular copper shield placed directly above the sensor. The performance and stability of the sensor are observed in conditions without and with copper shielding for a distance range of $d = 1$ cm - 2.5 cm. From the measurement results, the sensor has high stability both without and with disturbance with a Frequency Detection Resolution (FDR)

TABLE 3. Comparison with previous works.

Ref.	Method	Freq (GHz)	Range of ϵ_r	Performance			Num. of port	Dual-band performance	Confined E-field region	Disturbance analysis effect	High stability performance
				Max. FDR (GHz)	Max. NS. (%)	Max. Acc. (GHz)					
[8]	SRR	0.39	1 – 7.33	0.102	1.625	98.20	1	-	Yes	-	-
[10]	SSRR with spurlines	2.22	1 – 4.40	0.030	1.340	98.36	2	-	Yes	-	-
[13]	CSRR	2.65	1 – 3.00	0.150	5.380	97.71	2	-	Yes	-	-
[19]	IDC	2.65	1 – 6.15	0.373	4.300	99.99	2	-	Yes	-	-
[20]	IDC	2.35 / 5.79	1 – 10.5	0.150	3.980	99.99	2	-	Yes	-	-
[22]	Artificial Magnetic Conductor	4.04	1 – 4.40	0.070	1.890	96.48	1	-	Yes	-	-
[24]	Slot-loaded patch	2.50	1 – 10.20	0.072	5.240	98.80	1	-	-	-	-
[25]	Dual U-shaped	1.20 / 2.10	1 – 4.30	0.007	1.150	99.02	1	Yes	Yes	-	-
[26]	Aperture coupling	9.54 / 12.30	1 – 12.50	0.078	0.640	92.30	1	Yes	Yes	-	-
[27]	Dual T-shaped with IDC	1.64 / 2.43	1 – 6.15	0.016	0.003	95.99	1	Yes	Yes	-	-
[33]	SRR	1.24 / 2.08	1 – 6.00	0.050	4.101	96.97	2	Yes	Yes	-	-
This work	Asymmetric branch feed with IDC	1.61 / 2.52	1 – 6.15	0.110	4.330	95.98	1	Yes	Yes	Yes	Yes

of 0.009 - 0.4 GHz/ $\Delta\epsilon_r$, a Normalized Sensitivity (NS) of 0.4% - 4.4%, and an average accuracy of 90% - 95% for both resonance frequencies, respectively. Moreover, the proposed sensor has dual band performance with $f_{r1} = 1.62$ GHz and $f_{r2} = 2.52$ GHz. This dual-band capability allows for more accurate and reliable characterization of materials, as different frequencies can penetrate varying depths or interact with material properties differently, providing a broader dataset for analysis. Furthermore, dual-band operation helps mitigate the effects of noise or interference from environmental factors, as measurements from both bands can be cross-referenced for consistency.

V. CONCLUSION

This paper has successfully designed and realized a high stability single port dual-band microwave sensor using interdigital structure with asymmetry branch feedline for solid material characterization with permittivity range 1 - 6.15. The proposed sensor operates at two different resonance frequencies $f_{r1} = 1.61$ GHz and $f_{r2} = 2.52$ GHz. Based on the measurement results, the proposed sensor has high stability both without and with disturbance for $d = 1$ cm – 2.5 cm with a Frequency Detection Resolution (FDR) of 0.009 - 0.4 GHz/ $\Delta\epsilon_r$, a Normalized Sensitivity (NS) of 0.4% - 4.4%, and an average accuracy of 90% - 95% for both resonance frequencies, respectively. Therefore, this sensor can be recommended for several applications including biomedical industry, medicine and material quality control especially

for outdoor measurements that are potentially affected by electromagnetic interference and disturbance.

REFERENCES

- [1] K. S. L. Parvathi and S. R. Gupta, "Ultrahigh-sensitivity and compact EBG-based microwave sensor for liquid characterization," *IEEE Sensors Lett.*, vol. 6, no. 4, pp. 1–4, Apr. 2022, doi: [10.1109/LESENS.2022.3159800](https://doi.org/10.1109/LESENS.2022.3159800).
- [2] A. Armghan, T. M. Alanazi, A. Altaf, and T. Haq, "Characterization of dielectric substrates using dual band microwave sensor," *IEEE Access*, vol. 9, pp. 62779–62787, 2021, doi: [10.1109/ACCESS.2021.3075246](https://doi.org/10.1109/ACCESS.2021.3075246).
- [3] Z. Shaterian and M. Mrozowski, "Multifunctional bandpass filter/displacement sensor component," *IEEE Access*, vol. 11, pp. 27012–27019, 2023, doi: [10.1109/ACCESS.2023.3258545](https://doi.org/10.1109/ACCESS.2023.3258545).
- [4] A. Aquino, C. G. Juan, B. Potelon, and C. Quendo, "Dielectric permittivity sensor based on planar open-loop resonator," *IEEE Sensors Lett.*, vol. 5, no. 3, pp. 1–4, Mar. 2021, doi: [10.1109/LESENS.2021.3055544](https://doi.org/10.1109/LESENS.2021.3055544).
- [5] W. A. Jabbar, T. K. Kian, R. M. Ramli, S. N. Zubir, N. S. M. Zamrizaman, M. Balfaqih, V. Shepelev, and S. Alharbi, "Design and fabrication of smart home with Internet of Things enabled automation system," *IEEE Access*, vol. 7, pp. 144059–144074, 2019, doi: [10.1109/ACCESS.2019.2942846](https://doi.org/10.1109/ACCESS.2019.2942846).
- [6] A. Ebrahimi, J. Scott, and K. Ghorbani, "Ultrahigh-sensitivity microwave sensor for microfluidic complex permittivity measurement," *IEEE Trans. Microw. Theory Techn.*, vol. 67, no. 10, pp. 4269–4277, Oct. 2019, doi: [10.1109/TMTT.2019.2932737](https://doi.org/10.1109/TMTT.2019.2932737).
- [7] P. Jahangiri, M. Naser-Moghadasi, B. Ghalamkari, and M. Dousti, "A new planar microwave sensor for fat-measuring of meat based on SRR and periodic EBG structures," *Sens. Actuators A, Phys.*, vol. 346, Oct. 2022, Art. no. 113826, doi: [10.1016/j.sna.2022.113826](https://doi.org/10.1016/j.sna.2022.113826).
- [8] K. Xu, Y. Liu, S. Chen, P. Zhao, L. Peng, L. Dong, and G. Wang, "Novel microwave sensors based on split ring resonators for measuring permittivity," *IEEE Access*, vol. 6, pp. 26111–26120, 2018, doi: [10.1109/ACCESS.2018.2834726](https://doi.org/10.1109/ACCESS.2018.2834726).
- [9] W. Liu, J. Zhang, and K. Huang, "Dual-band microwave sensor based on planar rectangular cavity loaded with pairs of improved resonator for differential sensing applications," *IEEE Trans. Instrum. Meas.*, vol. 70, pp. 1–8, 2021, doi: [10.1109/TIM.2021.3118090](https://doi.org/10.1109/TIM.2021.3118090).

- [10] R. A. Alahnomi, Z. Zakaria, E. Ruslan, S. R. A. Rashid, and A. A. M. Bahar, "High-Q sensor based on symmetrical split ring resonator with spurlines for solids material detection," *IEEE Sensors J.*, vol. 17, no. 9, pp. 2766–2775, May 2017, doi: [10.1109/JSEN.2017.2682266](https://doi.org/10.1109/JSEN.2017.2682266).
- [11] M. Saadat-Safa, V. Nayyeri, M. Khanjarian, M. Soleimani, and O. M. Ramahi, "A CSRR-based sensor for full characterization of magneto-dielectric materials," *IEEE Trans. Microw. Theory Techn.*, vol. 67, no. 2, pp. 806–814, Feb. 2019, doi: [10.1109/TMTT.2018.2882826](https://doi.org/10.1109/TMTT.2018.2882826).
- [12] M. Abdolrazzaghi, N. Kazemi, V. Nayyeri, and F. Martin, "AI-assisted ultra-high-sensitivity/resolution active-coupled CSRR-based sensor with embedded selectivity," *Sensors*, vol. 23, no. 13, p. 6236, Jul. 2023, doi: [10.3390/s23136236](https://doi.org/10.3390/s23136236).
- [13] M. A. H. Ansari, A. K. Jha, and M. J. Akhtar, "Design and application of the CSRR-based planar sensor for noninvasive measurement of complex permittivity," *IEEE Sensors J.*, vol. 15, no. 12, pp. 7181–7189, Dec. 2015, doi: [10.1109/JSEN.2015.2469683](https://doi.org/10.1109/JSEN.2015.2469683).
- [14] A. A. M. Bahar, Z. Zakaria, M. K. M. Arshad, R. A. Alahnomi, A. I. Abu-Khadrah, and W. Y. Sam, "Microfluidic biochemical sensor based on circular SIW-DMS approach for dielectric characterization application," *Int. J. RF Microw. Comput.-Aided Eng.*, vol. 29, no. 9, pp. 1–13, Sep. 2019, doi: [10.1002/mmce.21801](https://doi.org/10.1002/mmce.21801).
- [15] A. A. M. Bahar, Z. Zakaria, M. K. M. Arshad, A. A. M. Isa, Y. Dasril, and R. A. Alahnomi, "Real time microwave biochemical sensor based on circular SIW approach for aqueous dielectric detection," *Sci. Rep.*, vol. 9, no. 1, pp. 1–12, Apr. 2019, doi: [10.1038/s41598-019-41702-3](https://doi.org/10.1038/s41598-019-41702-3).
- [16] J. Yeo and J.-I. Lee, "High-sensitivity microwave sensor based on an interdigital-capacitor-shaped defected ground structure for permittivity characterization," *Sensors*, vol. 19, no. 3, p. 498, Jan. 2019, doi: [10.3390/s19030498](https://doi.org/10.3390/s19030498).
- [17] S. Aiswarya, S. K. Menon, M. Donelli, and L. Meenu, "Development of a microwave sensor for solid and liquid substances based on closed loop resonator," *Sensors*, vol. 21, no. 24, p. 8506, Dec. 2021, doi: [10.3390/s21248506](https://doi.org/10.3390/s21248506).
- [18] L. Ali, C. Wang, I. Ullah, A. Yousaf, W. U. Khan, S. Ullah, R. Khan, F. Allassery, H. Hamam, and M. Shafiq, "Design and optimization of microwave sensor for the non-contact measurement of pure dielectric materials," *Electronics*, vol. 10, no. 24, p. 3057, Dec. 2021, doi: [10.3390/electronics10243057](https://doi.org/10.3390/electronics10243057).
- [19] L. Ali, C. Wang, F.-Y. Meng, K. K. Adhikari, Y.-C. Wei, J.-H. Li, Z.-W. Song, and M. Zhao, "Design and optimization of interdigitated microwave sensor for multidimensional sensitive characterization of solid materials," *IEEE Sensors J.*, vol. 21, no. 20, pp. 22814–22822, Oct. 2021, doi: [10.1109/JSEN.2021.3105410](https://doi.org/10.1109/JSEN.2021.3105410).
- [20] C. Wang, L. Ali, F.-Y. Meng, K. K. Adhikari, Z. L. Zhou, Y. C. Wei, D. Q. Zou, and H. Yu, "High-accuracy complex permittivity characterization of solid materials using parallel interdigital Capacitor-based planar microwave sensor," *IEEE Sensors J.*, vol. 21, no. 5, pp. 6083–6093, Mar. 2021, doi: [10.1109/JSEN.2020.3041014](https://doi.org/10.1109/JSEN.2020.3041014).
- [21] X. Bao, I. Ocket, J. Bao, Z. Liu, B. Puers, D. M. M.-P. Schreurs, and B. Nauwelaers, "Modeling of coplanar interdigital capacitor for microwave microfluidic application," *IEEE Trans. Microw. Theory Techn.*, vol. 67, no. 7, pp. 2674–2683, Jul. 2019, doi: [10.1109/TMTT.2019.2916871](https://doi.org/10.1109/TMTT.2019.2916871).
- [22] W. J. Wu and G. Wang, "A modified AMC-based antenna sensor for contactless measurement of complex permittivity," *Measurement*, vol. 206, Jun. 2023, Art. no. 112261, doi: [10.1016/j.measurement.2022.112261](https://doi.org/10.1016/j.measurement.2022.112261).
- [23] Q. Shi, X.-W. Xuan, H.-K. Nie, Z.-Y. Wang, and W. Wang, "Antenna sensor based on AMC array for contactless detection of water and ethanol in oil," *IEEE Sensors J.*, vol. 21, no. 19, pp. 21503–21510, Oct. 2021, doi: [10.1109/JSEN.2021.3102294](https://doi.org/10.1109/JSEN.2021.3102294).
- [24] J. Yeo and J.-I. Lee, "Slot-loaded microstrip patch sensor antenna for high-sensitivity permittivity characterization," *Electronics*, vol. 8, no. 5, p. 502, May 2019, doi: [10.3390/electronics8050502](https://doi.org/10.3390/electronics8050502).
- [25] S. Alam, Z. Zakaria, I. Surjati, N. A. Shairi, M. Alaydrus, and T. Firmansyah, "Dual-band independent permittivity sensor using single-port with a pair of U-shaped structures for solid material detection," *IEEE Sensors J.*, vol. 22, no. 16, pp. 16111–16119, Aug. 2022, doi: [10.1109/JSEN.2022.3191345](https://doi.org/10.1109/JSEN.2022.3191345).
- [26] M. Behdani, M. M. H. Kalateh, H. Saghlatoon, J. Melzer, and R. Mirzavand, "High-resolution dielectric constant measurement using a sensor antenna with an allocated link for data transmission," *IEEE Sensors J.*, vol. 20, no. 24, pp. 14827–14835, Dec. 2020, doi: [10.1109/JSEN.2020.3012055](https://doi.org/10.1109/JSEN.2020.3012055).
- [27] S. Alam, Z. Zakaria, I. Surjati, N. A. Shairi, M. Alaydrus, T. Firmansyah, Y. K. Ningsih, and L. Sari, "Collaboratively far-field and near-field regions for dual-modalities microwave permittivity sensor using T-shaped resonator embedded with IDC," *IEEE Sensors Lett.*, vol. 8, no. 7, pp. 1–4, Jul. 2024, doi: [10.1109/LSENS.2024.3415362](https://doi.org/10.1109/LSENS.2024.3415362).
- [28] S. Alam, Z. Zakaria, I. Surjati, N. A. Shairi, M. Alaydrus, and T. Firmansyah, "Multifunctional of dual-band permittivity sensors with antenna using multicascoded T-shaped resonators for simultaneous measurement of solid materials and data transfer capabilities," *Measurement*, vol. 217, Aug. 2023, Art. no. 113078, doi: [10.1016/j.measurement.2023.113078](https://doi.org/10.1016/j.measurement.2023.113078).
- [29] A. Ebrahimi, F. J. Tovar-Lopez, J. Scott, and K. Ghorbani, "Differential microwave sensor for characterization of glycerol–water solutions," *Sens. Actuators B, Chem.*, vol. 321, Oct. 2020, Art. no. 128561, doi: [10.1016/j.snb.2020.128561](https://doi.org/10.1016/j.snb.2020.128561).
- [30] S. Kiani, P. Rezaei, and M. Navaei, "Dual-sensing and dual-frequency microwave SRR sensor for liquid samples permittivity detection," *Measurement*, vol. 160, Aug. 2020, Art. no. 107805, doi: [10.1016/j.measurement.2020.107805](https://doi.org/10.1016/j.measurement.2020.107805).
- [31] S. Kiani, P. Rezaei, and M. Fakhr, "Real-time measurement of liquid permittivity through label-free meandered microwave sensor," *IETE J. Res.*, vol. 70, no. 5, pp. 4606–4616, May 2024, doi: [10.1080/03772063.2023.2231875](https://doi.org/10.1080/03772063.2023.2231875).
- [32] R. C. Caleffo and F. S. Corraera, "Liquids electrical characterization sensor using a hybrid SIW resonant cavity," *Microw. Opt. Technol. Lett.*, vol. 60, no. 2, pp. 445–449, Feb. 2018, doi: [10.1002/mop.30983](https://doi.org/10.1002/mop.30983).
- [33] A. A. Al-Behadili, I. A. Mocanu, N. Codreanu, and M. Pantazica, "Modified split ring resonators sensor for accurate complex permittivity measurements of solid dielectrics," *Sensors*, vol. 20, no. 23, p. 6855, Nov. 2020, doi: [10.3390/s20236855](https://doi.org/10.3390/s20236855).
- [34] S. Lim, C.-Y. Kim, and S. Hong, "Simultaneous measurement of thickness and permittivity by means of the resonant frequency fitting of a microstrip line ring resonator," *IEEE Microw. Wireless Compon. Lett.*, vol. 28, no. 6, pp. 539–541, Jun. 2018, doi: [10.1109/LMWC.2018.2833202](https://doi.org/10.1109/LMWC.2018.2833202).



SYAH ALAM (Member, IEEE) was born in Jakarta, Indonesia. He received the Bachelor of Education (S.Pd.) degree in electrical engineering from the Universitas Pendidikan Indonesia (UPI), in 2010, the M.Eng. (M.T.) degree in telecommunication engineering from the Graduate Program of Electrical Engineering, Universitas Trisakti, in 2012, and the Ph.D. degree in electronic engineering (RF and microwave) from the Universiti Teknikal Melaka Malaysia (UTeM), in 2024. In 2018, he joined the Department of Electrical Engineering, Universitas Trisakti, as a Researcher and a Lecturer. His research interests include microstrip antenna and microwave sensors for various applications.



INDRA SURJATI (Member, IEEE) was born in Bangkok, Thailand. She received the Bachelor of Engineering (Ir.) degree in electrical engineering and the M.Eng. (M.T.) degree in telecommunication engineering from the Graduate Program of Electrical Engineering, Universitas Trisakti, in 1996, and the Ph.D. degree from the Electrical Engineering Department, University of Indonesia, in 2004. In 2011, she was confirmed as a Professor with the Department of Electrical Engineering, Universitas Trisakti. Her research interests include microstrip antenna and microwave circuits for various applications.



LYDIA SARI (Member, IEEE) received the B.S. degree in electrical engineering from Universitas Trisakti, Jakarta, Indonesia, in 1998, and the M.S. and Ph.D. degrees in electrical engineering from the University of Indonesia, in 2002 and 2010, respectively. She is currently a Faculty Member with the Electrical Engineering Department, Universitas Trisakti. Her research interests include wireless communications and information theory.



RADEN DEINY MARDIAN (Member, IEEE) received the bachelor's and master's degrees in electrical engineering from Universitas Trisakti, Jakarta, Indonesia, in 1998 and 2001, respectively, and the Ph.D. degree in electrical engineering from Universitas Indonesia, Depok, Indonesia, in 2023. He has published several journal articles and conference proceedings. He is currently a Lecturer with the Electrical Engineering Department, Faculty of Industrial Technology, Universitas Trisakti.

His research interests include mobile and wireless communication technology, digital broadcasting, quality of service, and quality of experience—all his research concerns technical and regulatory policy management.



TEGUH FIRMANSYAH (Member, IEEE) was born in Subang, Indonesia. He received the B.Eng. and M.Eng. degrees in electrical engineering from the Department of Electrical Engineering, Universitas Indonesia, in 2010 and 2012, respectively, and the Dr.Eng. degree from Shizuoka University, Japan, in 2022. In 2012, he joined the Department of Electrical Engineering, Universitas Sultan Ageng Tirtayasa, as a Researcher and a Lecturer. He holds two patents for wideband antenna and multiband antenna. His research interests include microwave circuits for various applications and developing multifunctional sensors using acoustic, plasmonic, and microwave resonators.

His research interests include mobile and wireless communication technology, digital broadcasting, quality of service, and quality of experience—all his research concerns technical and regulatory policy management.

MUHAMMAD IQBAL, photograph and biography not available at the time of publication.

SLAMET WIDODO, photograph and biography not available at the time of publication.



MUDRIK ALAYDRUS (Senior Member, IEEE) was born in Jakarta, Indonesia. He received the Dipl.-Ing. degree in electrical engineering from Universitaet Hannover, in 1997, and the Dr.-Ing. degree in electrical engineering from Universitaet Wuppertal, in 2001. Since 2003, he has been with Universitas Mercu Buana, Jakarta. His current research interests include microwave and millimeter wave components, wireless power transfers, wireless sensor networks, the interaction between electromagnetics and materials, and mathematical modeling in signal processing. He is a member of Verein der Deutschen Elektroingenieure (VDE).

His research interests include mobile and wireless communication technology, digital broadcasting, quality of service, and quality of experience—all his research concerns technical and regulatory policy management.



ZAHRILADHA ZAKARIA (Senior Member, IEEE) was born in Johor, Malaysia. He received the B.Eng. and M.Eng. degrees in electrical and electronic engineering from the Universiti Teknologi Malaysia, in 1998 and 2004, respectively, and the Ph.D. degree in electrical and electronic engineering from the Institute of Microwaves and Photonics (IMP), University of Leeds, U.K., in 2010. From 1998 to 2002, he was with STMicroelectronics, Malaysia, where

he worked as a Product Engineer. He is currently a Professor with the Microwave Research Group (MRG), Faculty of Electronic and Computer Engineering, Universiti Teknikal Malaysia Melaka (UTeM). His research interests include a variety of microwave device development, such as planar and nonplanar microwave filters, resonators, amplifiers, and antennas. He also investigates energy harvesting and sensors.

...