



EDU VEST

JOURNAL OF UNIVERSAL STUDIES

Eduvest - Journal of Universal Studies is a double blind peer-reviewed academic journal and open access to multidisciplinary fields. The journal is published monthly by Green Publisher Indonesia. This journal publishes research articles multidisciplinary sciences.

P-ISSN: 2775-3735

E-ISSN 2775-3727

eduvest.greeninvest.co.id/index.php/edv

VOL 4 NO 12

Vol. 4 No. 6 (2024): Journal Eduvest - Journal of Universal Studies



DOI: <https://doi.org/10.59188/eduvest.v4i6>

Published: 2024-06-19

ABOUT JOURNAL

- [Focus and Scope](#)
- [Peer Review Process](#)
- [Reviewer](#)
- [Guidelines for Author](#)
- [Publication Ethics and Malpractice Statement](#)
- [Article Processing charge](#)
- [Copyright and License Statement](#)
- [Abstract and Indexing](#)
- [Plagiarism Policy](#)
- [Open Access Statement](#)

Reviewers

1. [Rohit Kumar Verma](#), Internasional Medical University, Malaysia
2. [Ahmad Fudholi](#), Universitas Kebangsaan Malaysia
3. [Najib Noorashid](#), Universitas Brunei Darussalam, Brunei Darussalam
4. [Muhammad Javed Iqbal](#), Sarhad University of Science and Information Technology, Pakistan
5. [Hamza Khalifa Ibrahim](#), Higher Institute of medical Technology, Bani Waleed, Libya
6. [Kanoksak Wattanachote](#), Guangdong University of Foreign Studies, Tiongkok, China
7. [Timilehin Olasoji](#), National Open University of Nigeria, Nigeria
8. [Hyunwoo Yoon](#), Department of Social Welfare, Kongju National University, South Korea
9. [Kaori Honjo](#), Osaka Medical and Pharmaceutical University, Japan
10. [Yolanda Lechon Perez](#), Polytechnic University of Madrid and Ciemat, Madrid, Spain
11. [Richard J. Hewitt](#), The James Hutton Institute, Aberdeen, United Kingdom
12. [Waqas Ahmad Wattoo](#), COMSATS University Islamabad, Pakistan
13. [Dayana Jalaludin](#), University Sains Malaysia, Malaysia
14. [Mustafa Özer](#), Anadolu University, Turkey
15. [Roymon Panjaitan](#), Universitas Sains dan Teknologi Komputer, Semarang
16. [Khaerul Wahidin](#), IAIN Syekh Nurjati Cirebon, Indonesia
17. [Komeil Raisian](#), Universiti Kebangsaan Malaysia, Malaysia
18. [Endang Sutrisno](#), Universitas Swadaya Gunung Jati, Indonesia
19. [Nur Aedi](#), Universitas Pendidikan Indonesia, Indonesia
20. [Achmad Faqih](#), Universitas Swadaya Gunung Jati, Indonesia
21. [Dian Indiyati](#), Universitas Telkom, Indonesia
22. [Abdul Hannan](#), University of the Punjab, Pakistan
23. [Jessy Fenn](#), Rajagiri College of Social Sciences, India
24. [Wike Pertiwi](#), Sekolah Tinggi Ilmu Ekonomi Cirebon, Indonesia
25. [Ismoil Ergashev](#), Samarkand Vocational Centre, Uzbekistan
26. [Showkat Ahmad Dar](#), Annamalai University, India
27. [Edi Ribut Harwanto](#), Universitas Muhammadiyah Metro, Indonesia
28. [Frahma Sekarningsih](#), Universitas Pendidikan Indonesia, Indonesia
29. [Issaoui Fakhri](#), King Khalid University, Abha, Saudi Arabia
30. [Bobur Baxtishodovich Sobirov](#), Samarkand Branch of Tashkent State University of Economics, Uzbekistan

IMPLEMENTATION OF 5D BUILDING INFORMATION MODELLING (BIM) SYSTEM ON QUAY WALL STRUCTURE BY PAYING ATTENTION TO CLASH DETECTION (CASE STUDY: PROJECT PATIMBAN PACKAGE 6)

Ruri Welda Palensia¹, Endah Kurniyaningrum², M. Zaki³, Darmawan Pontan⁴
^{1,2,3} Master of Civil Engineering Program, Universitas Trisakti, Indonesia
Email: ruriweldapalensia@gmail.com

ABSTRACT

Building Information Modeling (BIM) is one of the technologies in the field of AEC (Architecture, Engineering and Construction) that is able to simulate all information in a development project into a 3D model. Research in this thesis was carried out to analyze the results of the implementation of Building Information Modelling (BIM) 5D in dock work (Quay Wall Structure) by paying attention to clash detection at the pre-construction stage, with a case study of the Patimban Port Project Package 6. The focus of the research is the application of BIM 5D in identifying and resolving design clashes that can have an impact on the estimation of work volume and cost. The method used is qualitative and inductive analysis using Tekla Structure 2021 BIM software for 3D modeling and clash detection identification. The results of clash detection identification are grouped into three categories, namely large, medium, and small. The implementation of BIM 5D shows significant volume changes in some work items. The volume of the Deck Slab (Pier Head) and Front Wall decreased compared to the initial RAB, while the volume of the Deck Slab (In-Situ Concrete) increased. The cost comparison shows a savings of 7.06% of the total initial cost of RAB Quay Wall Structure, which is equivalent to IDR 10,502,919,303.55. The implementation of BIM 5D by conducting clash detection is quite effective in identifying and resolving design clashes, mitigating errors and revisions when entering the construction stage, and can increase project efficiency in better communication and coordination.

KEYWORDS *Building Information Modelling (BIM), BIM 5D, Clash Detection, Quay Wall Structure, Pre-Construction*



This work is licensed under a Creative Commons Attribution-ShareAlike 4.0 International

How to cite:

E-ISSN:

Ruri Welda Palensia, et al (2024). Implementation of 5D Building Information Modelling (BIM) System on Quay Wall Structure By Paying Attention to Clash Detection (Case Study: Project Patimban Package 6). *Journal Eduvest*. 4(12), 11792-11807
2775-3727

INTRODUCTION

Building Information Modeling (BIM) is one of the technologies in the field of AEC (Architecture Engineering and Construction) which is able to simulate all information in a construction project into a 3D model (Enshassi et al., 2018; Liu et al., 2019; Moreno et al., 2019; Safikhani et al., 2022). BIM is basically a digital platform for creating virtual buildings. If BIM is implemented, the model must be able to contain all the information of the building, which is used to collaborate, predict, and make decisions about the design, construction, cost, and maintenance stages of the building (Savitri et al., 2020). By using BIM, 3D, 4D, 5D, 6D and 7D can be obtained. For practitioners, the benefits of BIM are that they can make work easier, cost efficiency, time efficiency, save human resources, reduce rework, facilitate data integration, facilitate work documentation, and detect collisions during planning, and can better control the work. This can be done because in the process there is already a 3D visual model as a reference for work on construction projects.

Building modeling designed in 3D form can be known automatically if there is a plan/design error and is also able to detect from the beginning the existence / absence of a clash or conflict between structural systems or with other systems, making this BIM technology able to anticipate/minimize the existence of rework or additional work when construction has been carried out in the field. (Hager et al., 2016; Mésároš et al., 2021; Tretyakova et al., 2019). In the case study of the Patimban Port Package 6 project, it was built in an offshore area which has a depth of approximately six meters from the seabed to sea level. Offshore construction differs in planning from onshore construction and near shore construction and is a large platform that provides facilities such as a port (Natasha & Makarim, 2018). Which with the condition of the offshore construction site that cannot be predicted with certainty, it is very necessary to conduct a design review of the DED and work methods before construction begins. A design review process that is quite accurate is with BIM Implementation using Tekla 2021 software (Avenidaño et al., 2022, 2023; Fors, 2022; Nugroho Saputro et al., 2022; Ramawan et al., 2024).

The scope of this 5D BIM implementation research is the pier structure or Quay Wall Structure. The scheme to be studied is to issue a volume of design review results using Tekla BIM which can affect financing before construction begins. Project Monitoring, Clash detection (clash detection) or clash test is a terminology that generally aims to identify, review, and report faults in a project model, in the design and pre-construction stages. Clash (clash) occurs when elements from different models inhabit the same space and are carried out through the process of integrating various models. Clash detection It is used to check work both completed and in progress to minimize the risk of human error that is expected to occur in the construction stage. In this study, we want to analyze clash detection in the implementation of BIM applications with the aim of finding out the comparison or deviation between the conventional calculation of RAB (Cost Budget Plan) and BIM calculation in the case study of the Patimban Port Package 6 project.

In this study, which is the basis of the main problem related to the application of Building Information Modeling (BIM) at the pre-construction project

stage, namely how to implement the 5d building information modeling (BIM) system in the Patimban port project, especially the pier work (Quay Wall Structure) by paying attention to clash detection?

The purpose of this study is to analyze the application of 5D Building Information Modeling (BIM) based on clash detection.

This research is expected to provide several benefits as follows:

1. For the construction world, this research is expected to provide information about the most optimal strategies related to the application of Building Information Modeling (BIM) in 5D so that it can provide an overview to relevant stakeholders in determining policies in the construction sector in Indonesia, especially in dock work.
2. For the world of education, this research is expected to be able to contribute to the development and advancement of science, especially in the field of construction related to the application of Building Information Modeling (BIM) in 5D in construction projects in Indonesia, especially dock work.

RESEARCH METHOD

Description of the Research Location

Patimban Port is located in Patimban Village, Pusakanagara District, Subang Regency, West Java Province. Geographically, Patimban Port is located in the north of the north coast of West Java. The location of Patimban Port is located at $107^{\circ}54'8.54''E$ and $6^{\circ}13'50.08''LS$. Patimban Port is one of the main ports in Indonesia after Tanjung Priok Port, the port will become a large import and export traffic center in Indonesia and can be used for inter-island trade activities to face the golden Indonesia era in 2045.

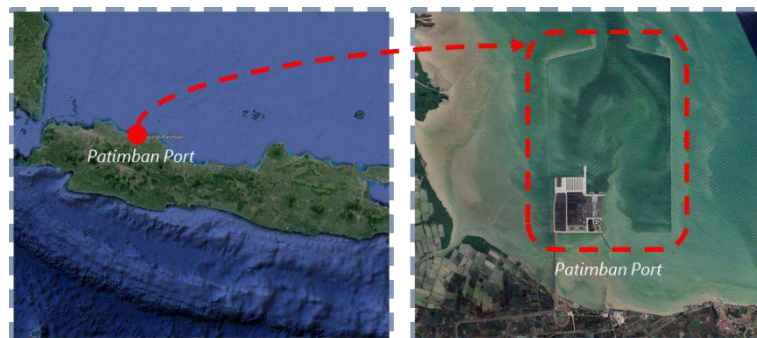

Picture 1. Location of the Port Project as a Case Study

Data Collection

In this case study, the research was developed using qualitative and inductive research methodologies (i.e. using literature, secondary data and expert interviews) and validated by applying the Port project case study to demonstrate the cost savings that can be achieved by clash detection generated by BIM implementation. This qualitative and inductive research methodology begins with the collection of secondary data such as complete planning data that will be modeled and processed into Tekla software which is then calculated to estimate the cost using BIM 5D.

Qualitative and inductive research also contains direct observation and analysis methods with the parties connected to this case study (Azungah, 2018; Morgan et al., 2017; Nugroho Saputro et al., 2022; Rashid et al., 2019). Secondary data includes DED Quay Wall Structure data, Contract Work Methods and conventional RAB (Cost Budget Plan) which will be a comparison with output cost data from BIM. The DED Quay Wall Structure data will be modeled or shaped using Tekla's BIM software. The model includes all the structural components and details necessary to ensure data accuracy and completeness.

Table 1. List of Participating Resource Persons

Tipe Narasumber	Sub-Job	Interview	Analisis Data	Analisis Biaya
			Clash Detection	Kuantifikasi Clash Detection
Desain	BIM Modeller	1	✓	✓
	BIM Engineer	1	✓	✓
Cost Control	Cost Control	1	x	✓
	Quantity Survey	1	x	✓
Pimpinan Kontraktor	Manajer Proyek	1	✓	✓
Konsultan	Konsultan Struktur	1	✓	✓

The scheme is validated through case studies on real projects, with participants described in the table. In the previous project, cost savings were made through clash detection analysis and also used case study methods to verify the work of the resource persons. Interviews were conducted to understand the process of clash detection, the practices applied in categorizing clash detection, and the procedure for its completion. The following is the layout of the Quay Wall Structure taken from DED data which will be processed into a 3D model in Tekla BIM.

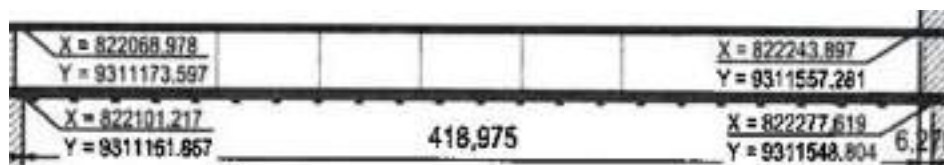

Picture 2. Layout of Quay Wall Structure

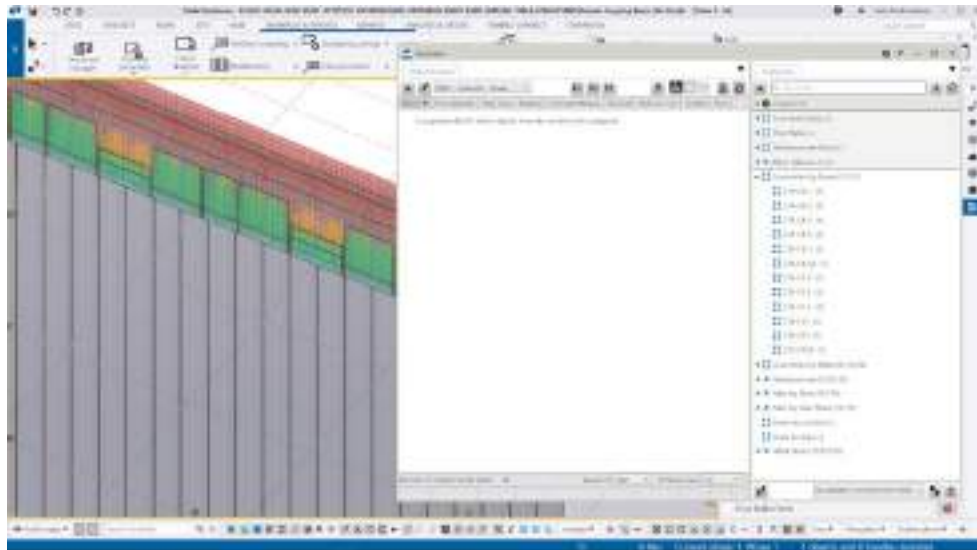

Picture 3. 3D BIM Display (Secondary Data Input on Tekla)

Data Processing

The entire data processing process in the design review is carried out using Tekla BIM software, which directly conducts design reviews in Tekla BIM software. Advanced data processing is assisted by trimble connect to facilitate communication during discussions and excel software for final data processing.



Picture 4. Software in Data Processing

In this data processing process, after obtaining the initial results, it is continued by comparing the realization of project costs with the project RAB that has been obtained from secondary data. Then a Clash Detection analysis was carried out on the modeling to find out the project costs that occurred.

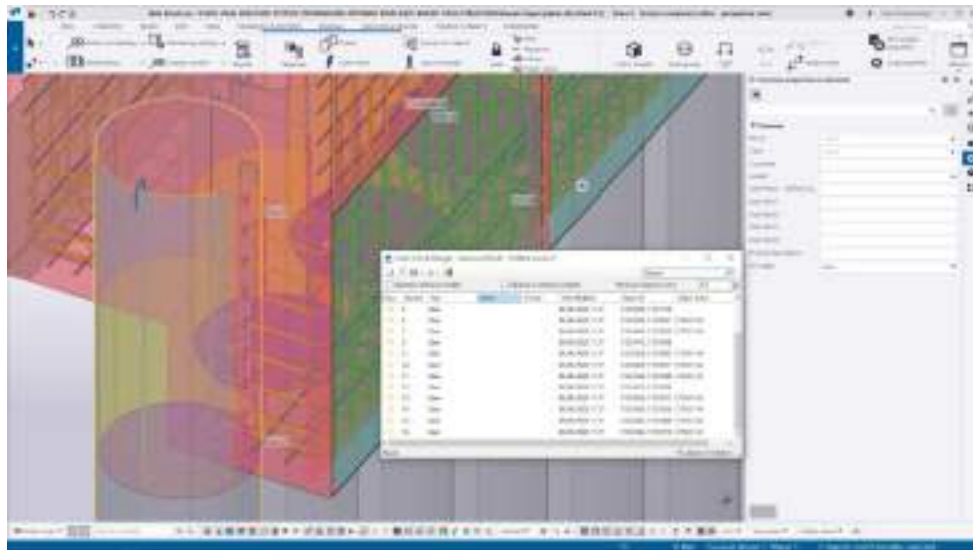

Picture 5. Clash Detection 3D BIM Display

Data Analysis

1. Modeling 3D Beam Tekla

The 3D modeling process using Tekla Structure 2021 BIM software is carried out to visualize all elements of the pier work (Quay Wall Structure) in detail.

2. Identify Clash Detection Categories

The clash detection category is determined based on the standards that have been set by the project team. This category includes the identification of large, medium, and minor clashes that affect the smooth running of the project.

3. Identify Clash Detection using Tekla BIM

After being completed in the 3D Model by BIM Modeller, at this stage, Clash Detection identification is carried out against the design review combined with the work method and actual conditions of the construction, to analyze each part of the work item on the pier work (Quay Wall Structure). From the results of clash detection, it will be categorized for the completion of clash detection.

4. Quantity Take Off and Analysis

After conducting clash detection, the next steps are to display the quantity take off from the 3D Modelbase that has been obtained as an estimate of the quantity take off of the material for the dock work.

Cost Analysis

1. Project Costs Based on RAB

This stage involves inputting the RAB cost of the project into Microsoft Excel software which will be used as a comparison with the cost after clash detection.

2. Project Cost Based on Clash Detection

After the calculation of clash detection, a re-cost analysis is carried out based on the results of the analysis clash detection.

3. Realistic Recapitulation of Costs Before and After Clash Detection

At this stage, a comparison of costs before and after clash detection is carried out .

4. BIM implementation analysis, 5D dimension

The analysis of BIM implementation in the 5D dimension includes an evaluation of the use of BIM in managing the cost and volume of Quay Wall Structure work. The results of this analysis provide a conclusion regarding the efficiency and effectiveness of the implementation of BIM 5D in the pier project, especially Quay Wall Structure.

Flow Chart

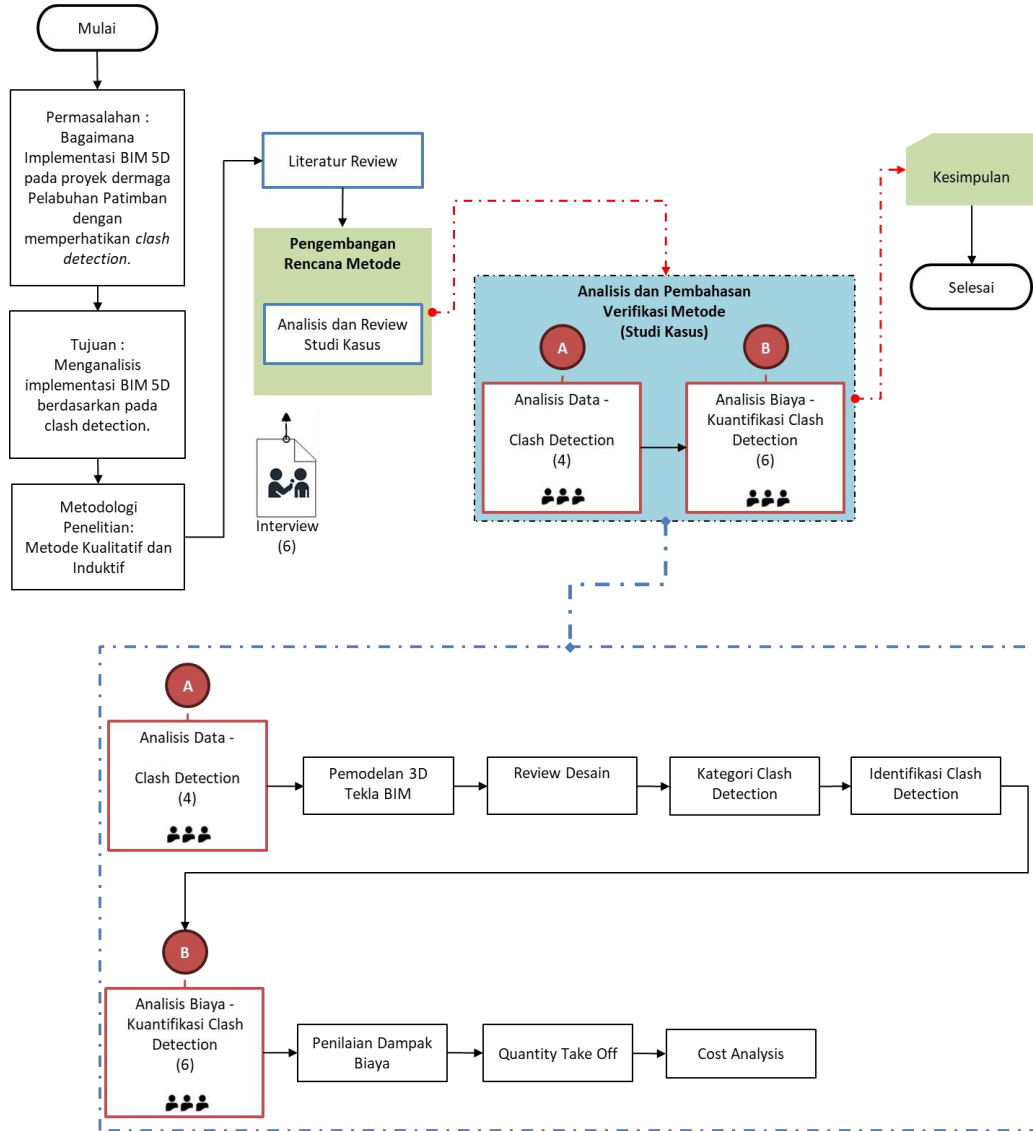

Picture 6. Research Flow Chart

RESULT AND DISCUSSION

Modelling 3D Tekla B

Implementation of 5D Building Information Modelling (BIM) System on Quay Wall Structure By Paying Attention to Clash Detection (Case Study: Project Patimban Package 6)

The 3D modeling in Tekla software is formed from the DED drawings of the Quay Wall Structure tender and combines the results of the design review of the tender work method based on the actual conditions of the project construction.

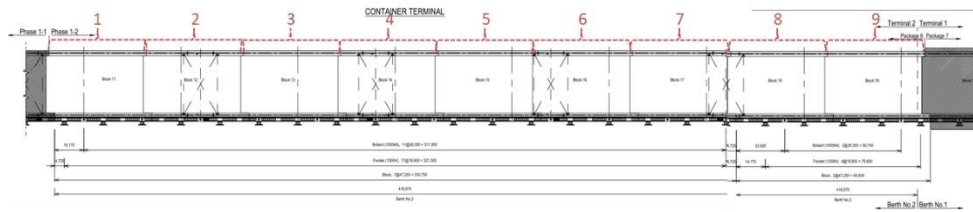

Picture 7. Layout Plan of Quay Wall Structure

This quay wall structure is divided into 9 blocks with the naming of DED starting from block number 11 to block 19 with a length of 47,250m per block. Since each block is a typical block, the 3D modeling takes one block to represent 9 blocks.

The following are the results of 3D modeling of a one-block quay wall structure in Tekla software after a combination of DED and review of tender work methods.

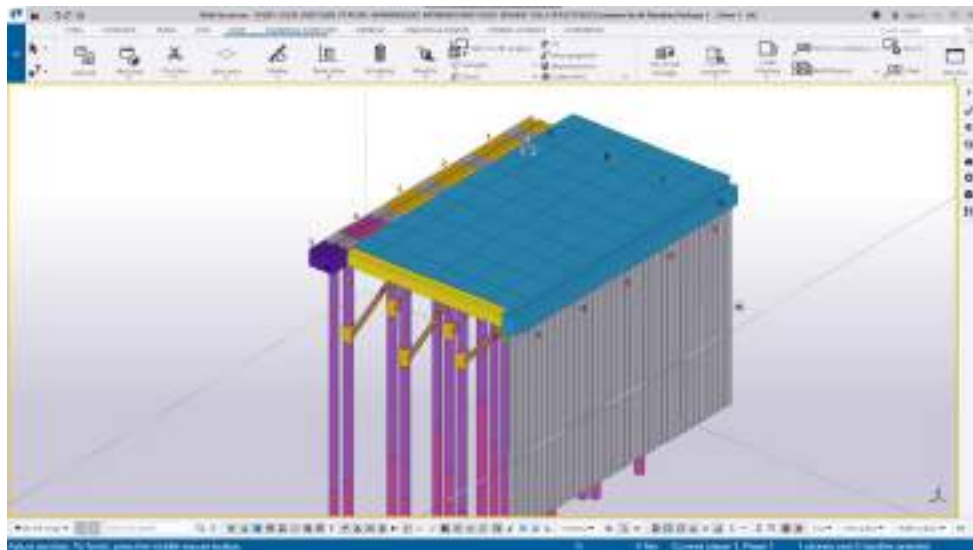

Picture 8. 3D Modeling of Rotary Wall Structure at Tekla

Identify Design Review with Stakeholders

The consultant assesses the impact of the clash detection on the project engineering specifications, project contracts, and field location situations. The consultant will give final design approval after a joint review. The cost calculation of the impact of BIM-based clash detection will also be discussed with the consultant by following the project scheme. All clashes can be prevented due to the results of clash detection processed by the results of the BIM implementation.

Category Identification

The categorization formed in this scheme comes from the problems for this project, so that clash detection can be put into large (Major), medium (Medium), or small (Minor) categories according to the impact of design changes and the involvement of contractors and consultants. Which large clash detection group will require the involvement of contractors, consultants, and project owners, because design changes can affect the volume of the contract so approval from the project owner's stakeholders is required. Medium clash detection groups require input from contractors and approval from consultants on proposed design reviews, while small clash detection groups i.e. contractors can complete without having to discuss with consultants and project owner stakeholders. Small bumps can be easily repaired by contractors. These categories are identified based on interviews and maps of the clash detection process. In this 3D Quay Wall Structure design, there are four work items that are locked or cannot be changed in the design of the DED because the work items are procurement and only installation in this project, namely:

1. SPSP
2. SPP
3. Strut Member
4. PC Deck Slab

Identify Clash Detection

Clash detection identification is carried out to facilitate the following analysis process, such as remodeling (resolve) and quantity & cost analysis. The identification process is carried out using the same software as 3D modeling, namely Tekla BIM. After 3D modeling of the DED and design review by the project BIM Team, the clash detection results were obtained from the Tekla system and then grouped into 3 groups. There are 5 Clash Detections included in a predetermined category based on the criteria of the Project BIM Team and the necessary actions. See the following table for the results of the clash detection category:

Table 2. Clash Detection by Category

No.	Uraian Pekerjaan	Clash Terhadap	Kategori		
			Mayor	Middle	Minor
1	SPSP	-	-	-	-
2	SPP	-	-	-	-
3	Strut Member	-	-	-	-
4	Deck Slab (Pier Head)	SPSP		1	
5	Deck Slab (In-Situ)	Deck Slab Pier Head		1	
6	Front Wall	SPP, Deck Slab Pier Head		1	
7	Coping Concrete	SPSP	1		
8	PC Deck Slab	-	-	-	-
9	Apron	-			1

As a result of the clash detection, one example was selected to represent each category of the three examples that displayed the 3D and 2D views of the model. The cost impact of this clash detection can be analyzed when the settlement design has been agreed. Only after analyzing the two conditions, namely the condition before the review and the condition after the review, can the quantification of each work item be carried out. The BIM system supports this effort by providing the

necessary information regarding the quantity before and after the design review of the RAB.

Examples of Major Main Categories

- a. BIM-based Clash Detection: Coping Concrete Design for SPSP
- b. Conflict Description: there is a clash of concrete Coping as a result of the design review visualized in Tekla BIM against SPSP piles
- c. BIM Solution: Shorten the horizontal rebar that will be attached to the SPSP pile.

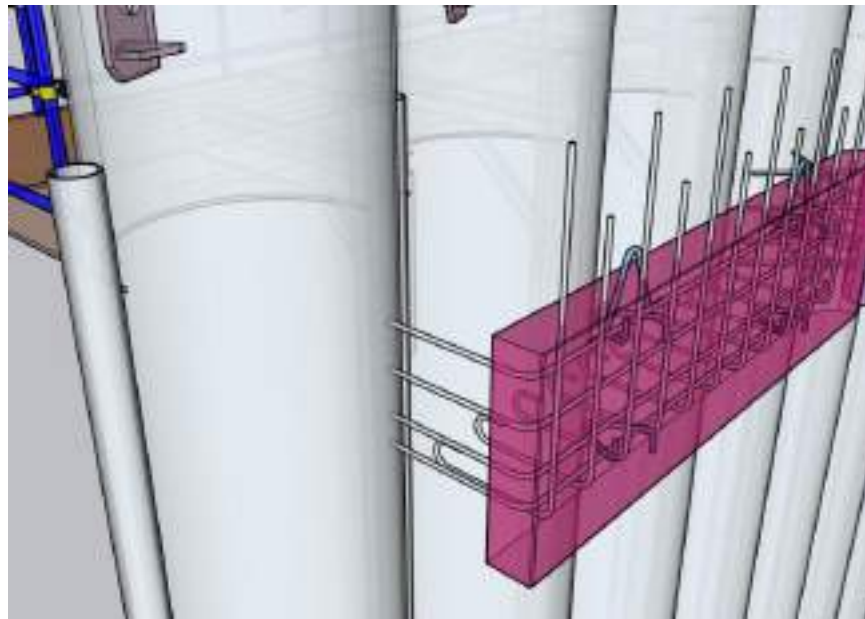

Picture 9. Clash Detection Coping Concrete

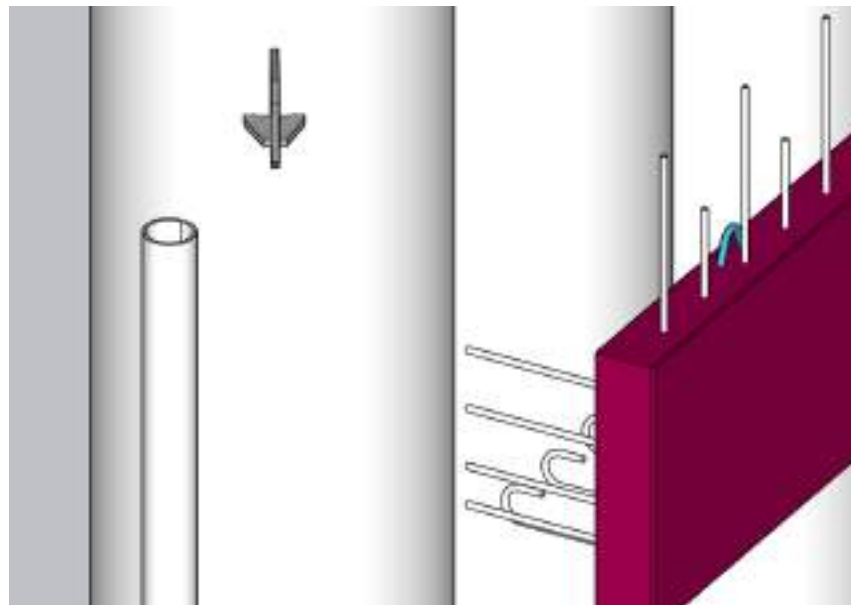

Picture 10. Clash Detection is solved with Rebar Adjustments

Here are the results of one of the clash detections, how clash detection design problems are identified and addressed.

d. Impact or Risk of Non-BIM system

If this clash is not detected and construction has been carried out in the field, then the construction of precast coping concrete can be stopped working so that it is constrained by other work that is directly in contact with precast coping. The case that can be identified is that it has an excess volume so that it cannot be applied in the field, so it must be reviewed again with the project design team and requires time in the field for the rebar cutting process.

Cost impact assessment on Clash Detection

This process is to evaluate the cost consequences of clash detection powered by BIM. This is done with the BIM team, Quantity Surveyor (QS) and the Project Head.

In this study, all the findings of clash detection were tabulated together. Clash detections from the large, medium, and small categories above are used as a guide to generate a range of cost savings on each clash detection category. Present details of the significant costs that will be incurred on the construction site when not implementing BIM. However, the cost implications during and after construction are not examined in the purpose of this study. Cost savings are made as a result of BIM implementation before construction begins.

Quantity Take Off

The final quantity of the volume of the 3D Quay Wall Structure model was obtained from Tekla BIM in the form of an excel file when exported from Tekla. The following is a view of the export results from the Tekla BIM system.

of the final results of the design review of BIM-based implementation. As is known, the design of points number 1 (SPP), 2 (SPSP), 3 (Strut Members), and 8 (PC Deck Slab) is not a changed design when there is a clash detection or design inconsistency with the review, so it can be seen that the points in the blue columns 4, 6, and 7, namely the Deck Slab (Pier Head), Front Wall, and Copping Concrete for SPSP have a reduced volume than the initial volume of the RAB. However, there is one job that has experienced an increase in volume from RAB, namely at pink point 5, Deck Slab (In-Situ concrete). And for point 9, namely the Concrete Apron has a very close volume.

Since the result of 1 typical block of the Quay Wall Structure is known, then adjust the overall volume of the Quay Wall Structure by multiplying each volume by 9 blocks as can be observed in the following table.

Table 4. Comparison of Volume 9 of RAB vs BIM Blocks

No.	Item Pekerjaan	Unit	BOQ	Review Desain Tekla	Selisih BOQ - Review Desain	Keterangan
			Volume	Volume	Volume	
1	2	3	4	5	6	7
1	Steel Pipe Pile (SPP)	no	189.00	189.00	-	Desain yang dikunci / tidak berubah
2	Steel Pipe Sheet Pile (SPSP)	no	315.00	315.00	-	Desain yang dikunci / tidak berubah
3	Strut Members	no	135.00	135.00	-	Desain yang dikunci / tidak berubah
4	Deck Slab (Pier Head)	cu.m	8,106.00	7,523.10	582.90	Volume review lebih kecil dari DED
5	Deck Slab (In-situ concrete)	cu.m	183.00	201.60	- 18.60	Volume review lebih besar dari DED
6	Front wall	cu.m	4,257.00	3,931.83	325.17	Volume review lebih kecil dari DED
7	Copping Concrete for SPSP	cu.m	3,707.00	3,393.09	313.91	Volume review lebih kecil dari DED
8	PC deck slab	no	1,620.00	1,620.00	-	Desain yang dikunci / tidak berubah
9	Apron Concrete	sq.m	11,801.00	11,800.69	0.31	Volume hampir sama dengan DED

Therefore, it is known that the final volume comparison data of the Quay Wall Structure results from the implementation of BIM.

Implementation of BIM 5D (Cost Analysis)

The implementation of BIM 5D (Cost Analysis) is the process of analyzing the results of processing BIM output data which is converted into costs. However, to find out the results of the data comparison after and before using BIM, the conventional data is processed by displaying the volume and amount of work prices using the help of Ms. Excel. The conventional calculation of the calculation of multiplying the unit price of RAB or contract is compared with the results of the Tekla design review.

The results of the volume quantity obtained from the implementation of BIM with Tekla will be analyzed using the same unit price as RAB. The final result will be displayed as in the following Table.

Table 5. RAB vs BIM Cost Comparison

No.	Item Pekerjaan	Unit	BOQ		Review Desain Tekla		Selisih BOQ - Review Desain (Rp)	Persentase Perubahan (%)
			Volume	Jumlah Harga (Rp)	Volume	Jumlah Harga (Rp)		
1	Steel Pipe Pile (SPP)	no	189.00	-	189.00	-	-	-
2	Steel Pipe Sheet Pile (SPSP)	no	315.00	-	315.00	-	-	-
3	Strut Members	no	135.00	-	135.00	-	-	-
4	Deck Slab (Pier Head)	cu.m	8,106.00	70,631,712,060.00	7,523.10	65,552,607,081.00	5,079,104,979.00	7.19%
5	Deck Slab (In-situ concrete)	cu.m	183.00	1,426,695,450.00	201.60	1,571,703,840.00	-145,008,390.00	-10.16%
6	Front wall	cu.m	4,257.00	37,093,412,070.00	3,931.83	34,260,040,023.30	2,833,372,046.70	7.64%
7	Coping Concrete for SPSP	cu.m	3,707.00	32,300,981,570.00	3,393.09	29,565,723,645.90	2,735,257,924.10	8.47%
8	PC deck slab	no	1,620.00	-	1,620.00	-	-	-
9	Apron Concrete	sq.m	11,801.00	7,278,620,780.00	11,800.69	7,278,428,036.25	192,743.75	0.00%
Total Jumlah Harga			148,731,421,930.00		138,228,502,626.45		10,502,919,303.55	7.06%
Terbilang		Seratus empat puluh delapan miliar tujuh ratus tiga puluh satu juta empat ratus dua puluh satu ribu sembilan ratus tiga puluh rupiah		Seratus tiga puluh delapan miliar dua ratus dua puluh delapan juta lima ratus dua ribu enam ratus dua puluh enam rupiah empat puluh lima rupiah		Sepuluh miliar lima ratus dua juta sembilan ratus sembilan belas ribu tiga ratus tiga puluh lima rupiah lima puluh lima rupiah		Total biaya yang dapat diidentifikasi berdasarkan implementasi BIM

Based on the results of the clash detection analysis and its completion, the work items that undergo changes in the volume of materials so that they affect the material costs that have been presented in the table, are as much as the cost of 7.06% (percent) of the total initial cost of the Quay Wall Structure. The difference in cost is around IDR 10,502,919,303.55 (Ten billion five hundred two million nine hundred nineteen thousand three hundred three rupiah fifty-five).

Comparative costs have been identified for each category of clashes. Averaging is considered for all categories to allow for a volume addendum in the project. The results obtained will be extrapolated to the overall cost savings achieved by this particular case study.

CONCLUSION

Based on the initial and final descriptions of the research that has been carried out regarding the Implementation of the 5D Building Information Modelling (BIM) System in Quay Wall Structure with Attention to Clash Detection (Case Study: Project Patimban Package 6), the following conclusions can be drawn:

1. The implementation of BIM 5D is essential in the pre-construction stage to ensure that the design is applicable and in accordance with the work plan, thereby reducing the potential for errors and improving project efficiency.
2. The results of clash detection identification showed that some work items such as Deck Slab (Pier Head), Front Wall, and Coping Concrete for SPSP experienced a decrease in volume compared to the initial RAB, while Deck Slab (In-Situ Concrete) experienced an increase in volume. This process helps in identifying potential problems early on and allows for necessary corrective action.
3. Based on the comparison between the volume of RAB and the results of the design review with Tekla BIM, it was found that there was a significant change in volume in several work items. This shows that the use of BIM in the design process can provide more accurate volume estimates.

4. The implementation of BIM 5D shows a cost saving of 7.06% of the total initial cost of the Quay Wall Structure, which is equivalent to IDR 10,502,919,303.55. Changes in material volume are identified through clash detection, which shows the great potential of BIM to improve cost efficiency in construction projects.
5. The implementation of BIM 5D with clash detection can identify and resolve potential clashes in the design during the contract design review, which can potentially reduce construction work errors occurring during the construction phase.
6. The use of BIM can be a means of assistance in better planning and coordination between project teams, which ultimately improves the efficiency and effectiveness of overall project execution.

REFERENCES

- Avendaño, J. I., Domingo, A., & Zlatanova, S. (2023). Building Information Modeling in Steel Building Projects Following BIM-DFE Methodology: A Case Study. *Buildings*, *13*(9), 2137. <https://doi.org/10.3390/buildings13092137>
- Avendaño, J. I., Zlatanova, S., Pérez, P., Domingo, A., & Correa, C. (2022). Integration of BIM in Steel Building Projects (BIM-DFE): A Delphi Survey. *Buildings*, *12*(9), 1439. <https://doi.org/10.3390/buildings12091439>
- Azungah, T. (2018). Qualitative research: deductive and inductive approaches to data analysis. *Qualitative Research Journal*, *18*(4), 383–400. <https://doi.org/10.1108/QRJ-D-18-00035>
- Enshassi, A. A., Hamra, L. A. A., & Alkilani, S. (2018). Studying the Benefits of Building Information Modeling (BIM) in Architecture, Engineering and Construction (AEC) Industry in the Gaza Strip. *Jordan Journal of Civil Engineering*, *12*(1).
- Fors, A. (2022). *Designing an application to improve cloning of BIM drawings-a feasibility study*.
- Hager, I., Golonka, A., & Putanowicz, R. (2016). 3D Printing of Buildings and Building Components as the Future of Sustainable Construction? *Procedia Engineering*, *151*, 292–299. <https://doi.org/10.1016/j.proeng.2016.07.357>
- Liu, Z., Lu, Y., & Peh, L. C. (2019). A Review and Scientometric Analysis of Global Building Information Modeling (BIM) Research in the Architecture, Engineering and Construction (AEC) Industry. *Buildings*, *9*(10), 210. <https://doi.org/10.3390/buildings9100210>
- Mésároš, P., Spišáková, M., Mandičák, T., Čabala, J., & Oravec, M. M. (2021). Adaptive Design of Formworks for Building Renovation Considering the Sustainability of Construction in BIM Environment—Case Study. *Sustainability*, *13*(2), 799. <https://doi.org/10.3390/su13020799>
- Moreno, C., Olbina, S., & Issa, R. R. (2019). BIM Use by Architecture, Engineering, and Construction (AEC) Industry in Educational Facility Projects. *Advances in Civil Engineering*, *2019*, 1–19. <https://doi.org/10.1155/2019/1392684>

- Morgan, S. J., Pullon, S. R. H., Macdonald, L. M., McKinlay, E. M., & Gray, B. V. (2017). Case Study Observational Research: A Framework for Conducting Case Study Research Where Observation Data Are the Focus. *Qualitative Health Research*, 27(7), 1060–1068. <https://doi.org/10.1177/1049732316649160>
- Natasha, I., & Makarim, C. A. (2018). ANALISIS KEGAGALAN TIANG PANCANG PADA KONSTRUKSI DERMAGA DENGAN PROGRAM APILE OFFSHORE, LPILE, DAN GRLWEAP. In *Jurnal Mitra Teknik Sipil* (Vol. 1, Issue 1).
- Nugroho Saputro, D., Intang Setyo Hermanto, N., Pamudji, G., Widyaningrum, A., & Susanto, H. (2022). Building Information Modeling (BIM) Basic Competency Training to improve Building Construction Service Design Products in Banyumas Regency. *SPEKTA (Jurnal Pengabdian Kepada Masyarakat : Teknologi Dan Aplikasi)*, 3(2), 159–166. <https://doi.org/10.12928/spekta.v3i2.6887>
- Ramawan, M. Y., Winanda, L. A. R., Aditama, V., Wijayaningtyas, M., & Kartika, D. (2024). *The effectiveness of BIM implementation in high-rise building*. 020028. <https://doi.org/10.1063/5.0205185>
- Rashid, Y., Rashid, A., Warraich, M. A., Sabir, S. S., & Waseem, A. (2019). Case Study Method: A Step-by-Step Guide for Business Researchers. *International Journal of Qualitative Methods*, 18, 160940691986242. <https://doi.org/10.1177/1609406919862424>
- Safikhani, S., Keller, S., Schweiger, G., & Pirker, J. (2022). Immersive virtual reality for extending the potential of building information modeling in architecture, engineering, and construction sector: systematic review. *International Journal of Digital Earth*, 15(1), 503–526. <https://doi.org/10.1080/17538947.2022.2038291>
- Savitri, D. M., Juliastuti, & Pramudya, A. A. (2020). Clash detection analysis with BIM-based software on midrise building construction project. *IOP Conference Series: Earth and Environmental Science*, 426(1). <https://doi.org/10.1088/1755-1315/426/1/012002>
- Tretyakova, Z. O., Voronina, M. V., & Merkulova, V. A. (2019). Geometric modelling of building forms using BIM, VR, AR-technology. *IOP Conference Series: Materials Science and Engineering*, 687(4), 044048. <https://doi.org/10.1088/1757-899X/687/4/044048>

Palensia

by Ruri Welda Palensia

Submission date: 07-Aug-2024 09:51AM (UTC+0700)

Submission ID: 2428418687

File name: Ruri_Welda_Palensia_-_Template.docx (3.09M)

Word count: 3879

Character count: 20224

IMPLEMENTATION OF 5D BUILDING INFORMATION MODELLING (BIM) SYSTEM ON QUAY WALL STRUCTURE BY PAYING ATTENTION TO CLASH DETECTION (CASE STUDY: PROJECT PATIMBAN PACKAGE 6)

ABSTRACT

Building Information Modeling (BIM) is one of the technologies in the field of AEC (Architecture, Engineering and Construction) that is able to simulate all information in a development project into a 3D model. Research in this thesis was carried out to analyze the results of the implementation of Building Information Modelling (BIM) 5D in dock work (Quay Wall Structure) by paying attention to clash detection at the pre-construction stage, with a case study of the Patimban Port Project Package 6. The focus of the research is the application of BIM 5D in identifying and resolving design clashes that can have an impact on the estimation of work volume and cost. The method used is qualitative and inductive analysis using Tekla Structure 2021 BIM software for 3D modeling and clash detection identification. The results of clash detection identification are grouped into three categories, namely large, medium, and small. The implementation of BIM 5D shows significant volume changes in some work items. The volume of the Deck Slab (Pier Head) and Front Wall decreased compared to the initial RAB, while the volume of the Deck Slab (In-Situ Concrete) increased. The cost comparison shows a savings of 7.06% of the total initial cost of RAB Quay Wall Structure, which is equivalent to IDR 10,502,919,303.55. The implementation of BIM 5D by conducting clash detection is quite effective in identifying and resolving design clashes, mitigating errors and revisions when entering the construction stage, and can increase project efficiency in better communication and coordination.

KEYWORDS Building Information Modeling (BIM), BIM 5D, Clash Detection, Quay Wall Structure, Pre-Construction

INTRODUCTION

Building Information Modeling (BIM) is one of the technologies in the field of AEC (Architecture Engineering and Construction) which is able to simulate all information in a construction project into a 3D model. BIM is basically a digital platform for creating virtual buildings. If BIM is implemented, the model must be able to contain all the information of the building, which is used to collaborate, predict, and make decisions about the design, construction, cost, and maintenance stages of the building (Savitri et al., 2020). By using BIM, 3D, 4D, 5D, 6D and 7D can be obtained. For practitioners, the benefits of BIM are that they can make work easier, cost efficiency, time efficiency, save human resources, reduce rework,

facilitate data integration, facilitate work documentation, and detect collisions during planning, and can better control the work. This can be done because in the process there is already a 3D visual model as a reference for work on construction projects. Building modeling designed in 3D form can be known automatically if there is a plan/design error and is also able to detect from the beginning the existence / absence of a clash or conflict between structural systems or with other systems, making this BIM technology able to anticipate/minimize the existence of rework or additional work when construction has been carried out in the field. (Ariani and Endah, 2021). In the case study of the Patimban Port Package 6 project, it was built in an offshore area which has a depth of approximately six meters from the seabed to sea level. Offshore construction differs in planning from onshore construction and near shore construction and is a large platform that provides facilities such as a port (Natasha and Makarim, 2018). Which with the condition of the offshore construction site that cannot be predicted with certainty, it is very necessary to conduct a design review of the DED and work methods before construction begins. A design review process that is quite accurate is with BIM Implementation using Tekla 2021 software. The scope of this 5D BIM implementation research is the pier structure or Quay Wall Structure. The scheme to be studied is to issue a volume of design review results using Tekla BIM which can affect financing before construction begins. Project Monitoring, Clash detection (clash detection) or clash test is a terminology that generally aims to identify, review, and report faults in a project model, in the design and pre-construction stages. Clash (clash) occurs when elements from different models inhabit the same space and are carried out through the process of integrating various models. Clash detection It is used to check work both completed and in progress to minimize the risk of human error that is expected to occur in the construction stage. In this study, we want to analyze clash detection in the implementation of BIM applications with the aim of finding out the comparison or deviation between the conventional calculation of RAB (Cost Budget Plan) and BIM calculation in the case study of the Patimban Port Package 6 project.

In **1**s study, which is the basis of the main problem related to the application of Building **2** Information Modeling (BIM) at the pre-construction project stage, namely how to implement the 5d building information modeling (BIM) system in the Patimban port project, especially the pier work (Quay Wall Structure) by pay **5** attention to clash detection?

The purpose of this study is to analyze the application of 5D Building Information Modeling (BIM) based on clash detection.

This research is expected to provide several benefits as follows:

1. For the construction world, this research is expected to provide information about the most optimal strategies related to the application of Building Information Modeling (BIM) in 5D so that it can provide an overview to relevant stakeholders in determining policies in the construction sector in Indonesia, especially in dock work. **1**
2. For the world of education, this research is expected to be able to contribute to the development and advancement of science, especially in the field of

construction related to the application of Building Information Modeling (BIM) in 5D in construction projects in Indonesia, especially dock work.

RESEARCH METHOD

Description of the Research Location

Patimban Port is located in Patimban Village, Pusakanagara District, Subang Regency, West Java Province. Geographically, Patimban Port is located in the north of the north coast of West Java. The location of Patimban Port is located at 107°54'8.54"E and 6°13'50.08"LS. Patimban Port is one of the main ports in Indonesia after Tanjung Priok Port, the port will become a large import and export traffic center in Indonesia and can be used for inter-island trade activities to face the golden Indonesia era in 2045.

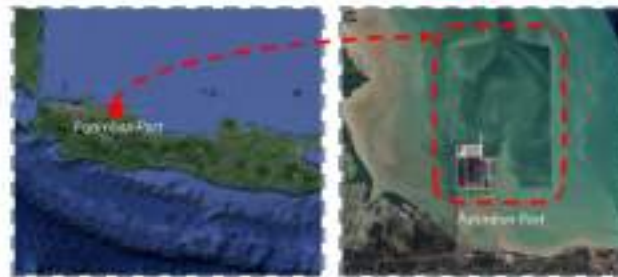

Picture 1. Location of the Port Project as a Case Study

Data Collection

In this case study, the research was developed using qualitative and inductive research methodologies (i.e. using literature, secondary data and expert interviews) and validated by applying the Port project case study to demonstrate the cost savings that can be achieved by clash detection generated by BIM implementation. This qualitative and inductive research methodology begins with the collection of secondary data such as complete planning data that will be modeled and processed into Tekla software which is then calculated to estimate the cost using BIM 5D. Qualitative and inductive research also contains direct observation and analysis methods with the parties connected to this case study. Secondary data includes DED Quay Wall Structure data, Contract Work Methods and conventional RAB (Cost Budget Plan) which will be a comparison with output cost data from BIM. The DED Quay Wall Structure data will be modeled or shaped using Tekla's BIM software. The model includes all the structural components and details necessary to ensure data accuracy and completeness.

Table 1. List of Participating Resource Persons

Tipe Narasumber	Sub-Job	Interview	Analysis Data	Analysis Biaya
			Clash Detection	Kuantifikasi Clash Detection
Desain	BIM Modeller	1	✓	✓
	BIM Engineer	1	✓	✓
Cost Control	Cost Control	1	x	✓
	Quantity Survey	1	x	✓
Pimpinan Kontraktor	Manajer Proyek	1	✓	✓
Konsultan	Konsultan Struktur	1	✓	✓

The scheme is validated through case studies on real projects, with participants described in the table. In the previous project, cost savings were made through clash detection analysis and also used case study methods to verify the work of the resource persons. Interviews were conducted to understand the process of clash detection, the practices applied in categorizing clash detection, and the procedure for its completion. The following is the layout of the Quay Wall Structure taken from DED data which will be processed into a 3D model in Tekla BIM.

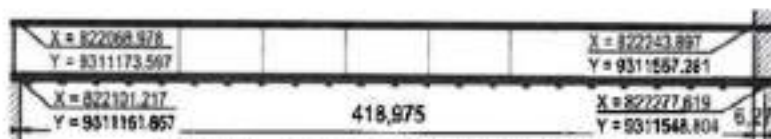

Picture 2. Layout of Quay Wall Structure

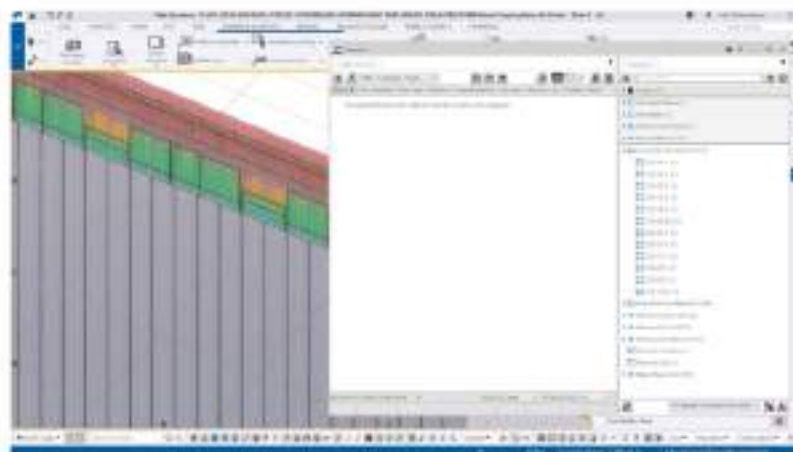

Picture 3. 3D BIM Display (Secondary Data Input on Tekla)

Data Processing

The entire data processing process in the design review is carried out using Tekla BIM software, which directly conducts design reviews in Tekla BIM software. Advanced data processing is assisted by trimble connect to facilitate communication during discussions and excel software for final data processing.



Picture 4. Software in Data Processing

In this data processing process, after obtaining the initial results, it is continued by comparing the realization of project costs with the project RAB that has been obtained from secondary data. Then a Clash Detection analysis was carried out on the modeling to find out the project costs that occurred.

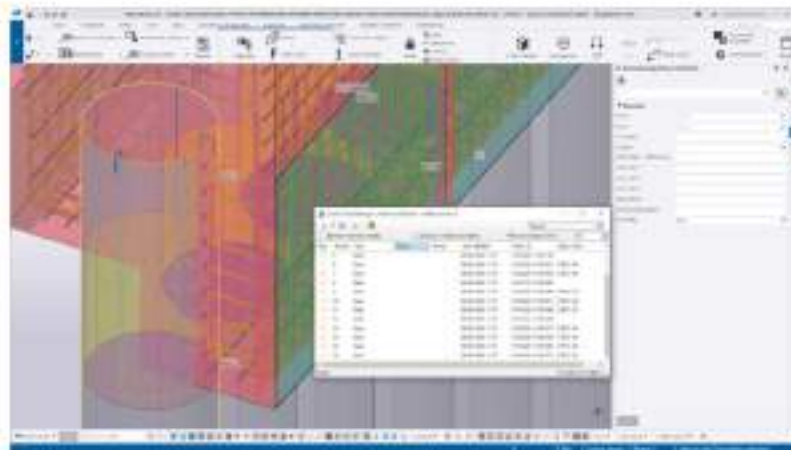

Picture 5. Clash Detection 3D BIM Display

Data Analysis

1. Modeling 3D Beam Tekla

The 3D modeling process using Tekla Structure 2021 BIM software is carried out to visualize all elements of the pier work (Quay Wall Structure) in detail.

2. Identify Clash Detection Categories

The clash detection category is determined based on the standards that have been set by the project team. This category includes the identification of large, medium, and minor clashes that affect the smooth running of the project.

3. Identify Clash Detection using Tekla BIM

After being completed in the 3D Model by BIM Modeller, at this stage, Clash Detection identification is carried out against the design review combined with the work method and actual conditions of the construction, to analyze each part of the work item on the pier work (Quay Wall Structure). From the results of clash detection, it will be categorized for the completion of clash detection.

4. Quantity Take Off and Analysis

After conducting clash detection, the next steps are to display the quantity take off from the 3D Modelbase that has been obtained as an estimate of the quantity take off of the material for the dock work.

Cost Analysis

1. Project Costs Based on RAB

This stage involves inputting the RAB cost of the project into Microsoft Excel software which will be used as a comparison with the cost after clash detection.

2. Project Cost Based on Clash Detection

After the calculation of clash detection, a re-cost analysis is carried out based on the results of the analysis clash detection.

3. Realistic Recapitulation of Costs Before and After Clash Detection

At this stage, a comparison of costs before and after clash detection is carried out .

4. BIM implementation analysis, 5D dimension

The analysis of BIM implementation in the 5D dimension includes an evaluation of the use of BIM in managing the cost and volume of Quay Wall Structure work. The results of this analysis provide a conclusion regarding the efficiency and effectiveness of the implementation of BIM 5D in the pier project, especially Quay Wall Structure.

Flow Chart

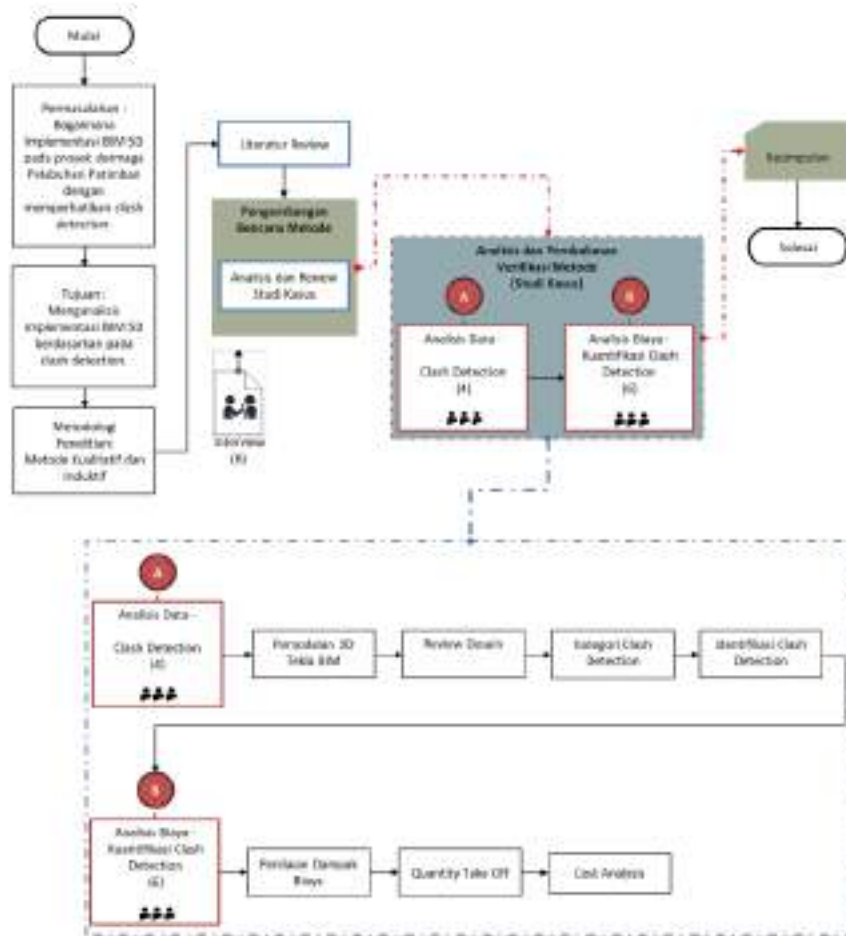

Picture 6. Research Flow Chart

RESULT AND DISCUSSION

Pemodelan 3D Tekla B

The 3D modeling in Tekla software is formed from the DED drawings of the Quay Wall Structure tender and combines the results of the design review of the tender work method based on the actual conditions of the project construction.

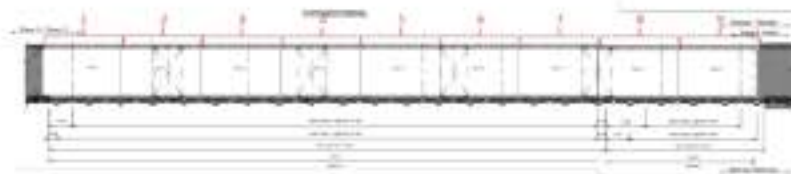

Picture 7. Layout Plan of Quay Wall Structure

This quay wall structure is divided into 9 blocks with the naming of DED starting from block number 11 to block 19 with a length of 47,250m per block. Since each block is a typical block, the 3D modeling takes one block to represent 9 blocks.

The following are the results of 3D modeling of a one-block quay wall structure in Tekla software after a combination of DED and review of tender work methods.

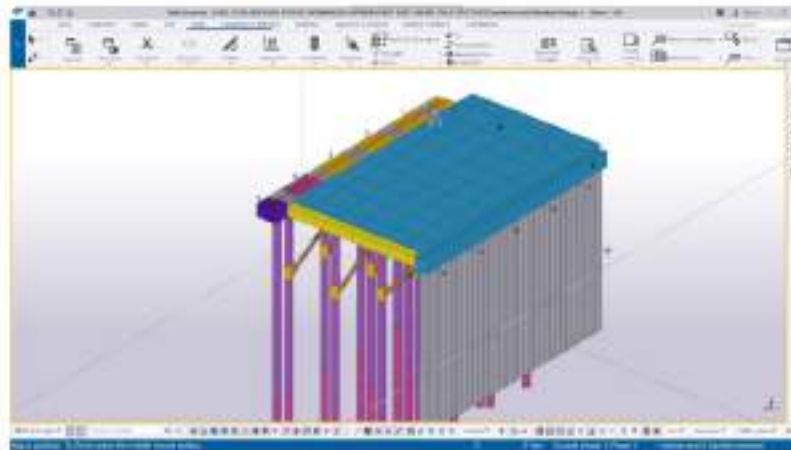

Picture 8. 3D Modeling of Rotary Wall Structure at Tekla

Identify Design Review with Stakeholders

The consultant assesses the impact of the clash detection on the project engineering specifications, project contracts, and field location situations. The consultant will give final design approval after a joint review. The cost calculation of the impact of BIM-based clash detection will also be discussed with the consultant by following the project scheme. All clashes can be prevented due to the results of clash detection processed by the results of the BIM implementation.

Category Identification

The categorization formed in this scheme comes from the problems for this project, so that clash detection can be put into large (Major), medium (Medium), or small (Minor) categories according to the impact of design changes and the involvement of contractors and consultants. Which large clash detection group will require the involvement of contractors, consultants, and project owners, because

design changes can affect the volume of the contract so approval from the project owner's stakeholders is required. Medium clash detection groups require input from contractors and approval from consultants on proposed design reviews, while small clash detection groups i.e. contractors can complete without having to discuss with consultants and project owner stakeholders. Small bumps can be easily repaired by contractors. These categories are identified based on interviews and maps of the clash detection process. In this 3D Quay Wall Structure design, there are four work items that are locked or cannot be changed in the design of the DED because the work items are procurement and only installation in this project, namely:

1. SPSP
2. SPP
3. Strut Member
4. PC Deck Slab

Identify Clash Detection

Clash detection identification is carried out to facilitate the following analysis process, such as remodeling (resolve) and quantity & cost analysis. The identification process is carried out using the same software as 3D modeling, namely Tekla BIM. After 3D modeling of the DED and design review by the project BIM Team, the clash detection results were obtained from the Tekla system and then grouped into 3 groups. There are 5 Clash Detections included in a predetermined category based on the criteria of the Project BIM Team and the necessary actions. See the following table for the results of the clash detection category:

Table 2. Clash Detection by Category

No.	Uraian Pekerjaan	Clash Terhadap	Kategori		
			Mayor	Middle	Minor
1	SPSP	-	-	-	-
2	SPP	-	-	-	-
3	Strut Member	-	-	-	-
4	Deck Slab (Pier Head)	SPSP			1
5	Deck Slab (In-Situ)	Deck Slab Pier Head			1
6	Front Wall	SPP, Deck Slab Pier Head			1
7	Coping Concrete	SPSP	1		
8	PC Deck Slab	-	-	-	-
9	Apron	-			1

As a result of the clash detection, one example was selected to represent each category of the three examples that displayed the 3D and 2D views of the model. The cost impact of this clash detection can be analyzed when the settlement design has been agreed. Only after analyzing the two conditions, namely the condition before the review and the condition after the review, can the quantification of each work item be carried out. The BIM system supports this effort by providing the necessary information regarding the quantity before and after the design review of the RAB.

Examples of Major Main Categories

- a. BIM-based Clash Detection: Coping Concrete Design for SPSP
- b. Conflict Description: there is a clash of concrete Coping as a result of the design review visualized in Tekla BIM against SPSP piles

- e. BIM Solution: Shorten the horizontal rebar that will be attached to the SPSP pile.

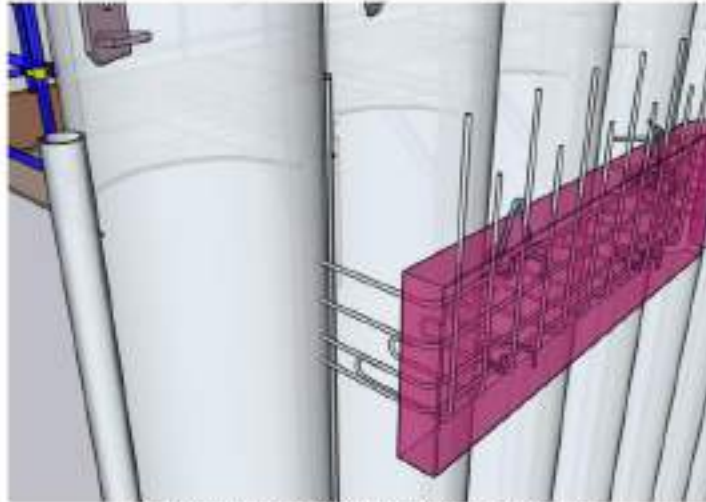

Picture 9. Clash Detection Coping Concrete

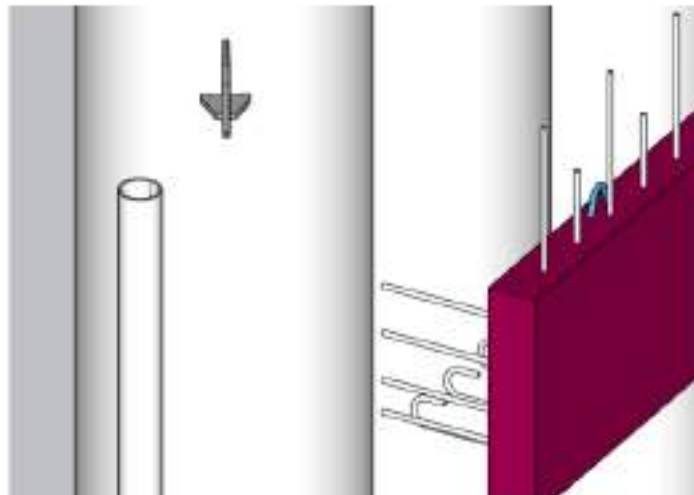

Picture 10. Clash Detection is solved with Rebar Adjustments

Here are the results of one of the clash detections, how clash detection design problems are identified and addressed.

- d. Impact or Risk of Non-BIM system

If this clash is not detected and construction has been carried out in the field, then the construction of precast coping concrete can be stopped working so that it

is constrained by other work that is directly in contact with precast coping. The case that can be identified is that it has an excess volume so that it cannot be applied in the field, so it must be reviewed again with the project design team and requires time in the field for the rebar cutting process.

Cost impact assessment on Clash Detection

This process is to evaluate the cost consequences of clash detection powered by BIM. This is done with the BIM team, Quantity Surveyor (QS) and the Project Head.

In this study, all the findings of clash detection were tabulated together. Clash detections from the large, medium, and small categories above are used as a guide to generate a range of cost savings on each clash detection category. Present details of the significant costs that will be incurred on the construction site when not implementing BIM. However, the cost implications during and after construction are not examined in the purpose of this study. Cost savings are made as a result of BIM implementation before construction begins.

Quantity Take Off

The final quantity of the volume of the 3D Quay Wall Structure model was obtained from Tekla BIM in the form of an excel file when exported from Tekla. The following is a view of the export results from the Tekla BIM system.



Item	Material	Profile	Length (mm)	Top level (mm)	Volume (m3)	Section
AS FENDER	Concrete	Undefined	2902'4600	4.000.00	2.540.00	30.69
AS FENDER	Concrete	Undefined	2902'4600	4.000.00	2.540.00	30.69
AS FENDER	Concrete	Undefined	2902'4600	4.000.00	2.540.00	30.69
AS NON FENDER	Concrete	Undefined	2902'4600	4.000.00	2.540.00	27.41
AS NON FENDER	Concrete	Undefined	2902'4600	4.000.00	2.540.00	27.41
Apron 1	Concrete	Undefined	1302'3625	3.625.00	2.648.00	1.4
Apron 1	Concrete	Undefined	1302'3625	3.625.00	2.618.00	1.4
Apron 1	Concrete	Undefined	1302'3625	3.625.00	2.648.00	1.4
Apron 1	Concrete	Undefined	1302'3625	3.625.00	2.618.00	1.4
Apron 2	Concrete	Undefined	1302'3625	3.625.00	2.620.46	1.81
Apron 2	Concrete	Undefined	1302'3625	3.625.00	2.672.75	1.81
Apron 2	Concrete	Undefined	1302'3625	3.625.00	2.725.16	1.81
Apron 2	Concrete	Undefined	1302'3625	3.625.00	2.777.46	1.81
Apron 2	Concrete	Undefined	1302'3625	3.625.00	2.620.46	1.81
Apron 2	Concrete	Undefined	1302'3625	3.625.00	2.725.16	1.81
Apron 2	Concrete	Undefined	1302'3625	3.625.00	2.672.75	1.81
Apron 2	Concrete	Undefined	1302'3625	3.625.00	2.777.46	1.81
Apron 3	Concrete	Undefined	1302'3875	3.800.00	2.568.00	1.94
Apron 3	Concrete	Undefined	1302'3875	3.800.00	2.618.00	1.94
Apron 3	Concrete	Undefined	1302'3875	3.800.00	2.668.00	1.94
Apron 3	Concrete	Undefined	1302'3875	3.800.00	2.618.00	1.94
Apron 3	Concrete	Undefined	1302'3875	3.800.00	2.668.00	1.94
Apron 3	Concrete	Undefined	1302'3875	3.800.00	2.618.00	1.94
Apron 3	Concrete	Undefined	1302'3875	3.800.00	2.668.00	1.94
Apron 3	Concrete	Undefined	1302'3875	3.800.00	2.618.00	1.94
Apron 3	Concrete	Undefined	1302'3875	3.800.00	2.668.00	1.94
Apron 3	Concrete	Undefined	1302'3875	3.800.00	2.618.00	1.94
Apron 3	Concrete	Undefined	1302'3875	3.800.00	2.668.00	1.94
Apron 3	Concrete	Undefined	1302'3875	3.800.00	2.618.00	1.94
Apron 3	Concrete	Undefined	1302'3875	3.800.00	2.668.00	1.94
Apron 3	Concrete	Undefined	1302'3875	3.800.00	2.618.00	1.94
Apron 3	Concrete	Undefined	1302'3875	3.800.00	2.668.00	1.94
Apron 3	Concrete	Undefined	1302'3875	3.800.00	2.618.00	1.94
Apron 3	Concrete	Undefined	1302'3875	3.800.00	2.668.00	1.94
Apron 3	Concrete	Undefined	1302'3875	3.800.00	2.618.00	1.94
Apron 3	Concrete	Undefined	1302'3875	3.800.00	2.668.00	1.94
Apron 3	Concrete	Undefined	1302'3875	3.800.00	2.618.00	1.94
Apron 3	Concrete	Undefined	1302'3875	3.800.00	2.668.00	1.94
Apron 3	Concrete	Undefined	1302'3875	3.800.00	2.618.00	1.94
Apron 3	Concrete	Undefined	1302'3875	3.800.00	2.668.00	1.94
Apron 3	Concrete	Undefined	1302'3875	3.800.00	2.618.00	1.94
Apron 3	Concrete	Undefined	1302'3875	3.800.00	2.668.00	1.94
Apron 3	Concrete	Undefined	1302'3875	3.800.00	2.618.00	1.94
Apron 3	Concrete	Undefined	1302'3875	3.800.00	2.668.00	1.94
Apron 3	Concrete	Undefined	1302'3875	3.800.00	2.618.00	1.94
Apron 3	Concrete	Undefined	1302'3875	3.800.00	2.668.00	1.94
Apron 3	Concrete	Undefined	1302'3875	3.800.00	2.618.00	1.94
Apron 3	Concrete	Undefined	1302'3875	3.800.00	2.668.00	1.94
Apron 3	Concrete	Undefined	1302'3875	3.800.00	2.618.00	1.94
Apron 3	Concrete	Undefined	1302'3875	3.800.00	2.668.00	1.94
Apron 3	Concrete	Undefined	1302'3875	3.800.00	2.618.00	1.94
Apron 3	Concrete	Undefined	1302'3875	3.800.00	2.668.00	1.94
Apron 3	Concrete	Undefined	1302'3875	3.800.00	2.618.00	1.94
Apron 3	Concrete	Undefined	1302'3875	3.800.00	2.668.00	1.94
Apron 3	Concrete	Undefined	1302'3875	3.800.00	2.618.00	1.94
Apron 3	Concrete	Undefined	1302'3875	3.800.00	2.668.00	1.94
Apron 3	Concrete	Undefined	1302'3875	3.800.00	2.618.00	1.94
Apron 3	Concrete	Undefined	1302'3875	3.800.00	2.668.00	1.94
Apron 3	Concrete	Undefined	1302'3875	3.800.00	2.618.00	1.94
Apron 3	Concrete	Undefined	1302'3875	3.800.00	2.668.00	1.94
Apron 3	Concrete	Undefined	1302'3875	3.800.00	2.618.00	1.94
Apron 3	Concrete	Undefined	1302'3875	3.800.00	2.668.00	1.94
Apron 3	Concrete	Undefined	1302'3875	3.800.00	2.618.00	1.94
Apron 3	Concrete	Undefined	1302'3875	3.800.00	2.668.00	1.94
Apron 3	Concrete	Undefined	1302'3875	3.800.00	2.618.00	1.94
Apron 3	Concrete	Undefined	1302'3875	3.800.00	2.668.00	1.94
Apron 3	Concrete	Undefined	1302'3875	3.800.00	2.618.00	1.94
Apron 3	Concrete	Undefined	1302'3875	3.800.00	2.668.00	1.94
Apron 3	Concrete	Undefined	1302'3875	3.800.00	2.618.00	1.94
Apron 3	Concrete	Undefined	1302'3875	3.800.00	2.668.00	1.94
Apron 3	Concrete	Undefined	1302'3875	3.800.00	2.618.00	1.94
Apron 3	Concrete	Undefined	1302'3875	3.800.00	2.668.00	1.94
Apron 3	Concrete	Undefined	1302'3875	3.800.00	2.618.00	1.94
Apron 3	Concrete	Undefined	1302'3875	3.800.00	2.668.00	1.94
Apron 3	Concrete	Undefined	1302'3875	3.800.00	2.618.00	1.94
Apron 3	Concrete	Undefined	1302'3875	3.800.00	2.668.00	1.94
Apron 3	Concrete	Undefined	1302'3875	3.800.00	2.618.00	1.94
Apron 3	Concrete	Undefined	1302'3875	3.800.00	2.668.00	1.94
Apron 3	Concrete	Undefined	1302'3875	3.800.00	2.618.00	1.94
Apron 3	Concrete	Undefined	1302'3875	3.800.00	2.668.00	1.94
Apron 3	Concrete	Undefined	1302'3875	3.800.00	2.618.00	1.94
Apron 3	Concrete	Undefined	1302'3875	3.800.00	2.668.00	1.94
Apron 3	Concrete	Undefined	1302'3875	3.800.00	2.618.00	1.94
Apron 3	Concrete	Undefined	1302'3875	3.800.00	2.668.00	1.94
Apron 3	Concrete	Undefined	1302'3875	3.800.00	2.618.00	1.94
Apron 3	Concrete	Undefined	1302'3875	3.800.00	2.668.00	1.94
Apron 3	Concrete	Undefined	1302'3875	3.800.00	2.618.00	1.94
Apron 3	Concrete	Undefined	1302'3875	3.800.00	2.668.00	1.94
Apron 3	Concrete	Undefined	1302'3875	3.800.00	2.618.00	1.94
Apron 3	Concrete	Undefined	1302'3875	3.800.00	2.668.00	1.94
Apron 3	Concrete	Undefined	1302'3875	3.800.00	2.618.00	1.94
Apron 3	Concrete	Undefined	1302'3875	3.800.00	2.668.00	1.94
Apron 3	Concrete	Undefined	1302'3875	3.800.00	2.618.00	1.94
Apron 3	Concrete	Undefined	1302'3875	3.800.00	2.668.00	1.94
Apron 3	Concrete	Undefined	1302'3875	3.800.00	2.618.00	1.94
Apron 3	Concrete	Undefined	1302'3875	3.800.00	2.668.00	1.94
Apron 3	Concrete	Undefined	1302'3875	3.800.00	2.618.00	1.94
Apron 3	Concrete	Undefined	1302'3875	3.800.00	2.668.00	1.94
Apron 3	Concrete	Undefined	1302'3875	3.800.00	2.618.00	1.94
Apron 3	Concrete	Undefined	1302'3875	3.800.00	2.668.00	1.94
Apron 3	Concrete	Undefined	1302'3875	3.800.00	2.618.00	1.94
Apron 3	Concrete	Undefined	1302'3875	3.800.00	2.668.00	1.94
Apron 3	Concrete	Undefined	1302'3875	3.800.00	2.618.00	1.94
Apron 3	Concrete	Undefined	1302'3875	3.800.00	2.668.00	1.94
Apron 3	Concrete	Undefined	1302'3875	3.800.00	2.618.00	1.94
Apron 3	Concrete	Undefined	1302'3875	3.800.00	2.668.00	1.94
Apron 3	Concrete	Undefined	1302'3875	3.800.00	2.618.00	1.94
Apron 3	Concrete	Undefined	1302'3875	3.800.00	2.668.00	1.94
Apron 3	Concrete	Undefined	1302'3875	3.800.00	2.618.00	1.94
Apron 3	Concrete	Undefined	1302'3875	3.800.00	2.668.00	1.94
Apron 3	Concrete	Undefined	1302'3875	3.800.00	2.618.00	1.94
Apron 3	Concrete	Undefined	1302'3875	3.800.00	2.668.00	1.94
Apron 3	Concrete	Undefined	1302'3875	3.800.00	2.618.00	1.94
Apron 3	Concrete	Undefined	1302'3875	3.800.00	2.668.00	1.94
Apron 3	Concrete	Undefined	1302'3875	3.800.00	2.618.00	1.94
Apron 3	Concrete	Undefined	1302'3875	3.800.00	2.668.00	1.94
Apron 3	Concrete	Undefined	1302'3875	3.800.00	2.618.00	1.94
Apron 3	Concrete	Undefined	1302'3875	3.800.00	2.668.00	1.94
Apron 3	Concrete	Undefined	1302'3875	3.800.00	2.618.00	1.94
Apron 3	Concrete	Undefined	1302'3875	3.800.00	2.668.00	1.94
Apron 3	Concrete	Undefined	1302'3875	3.800.00	2.618.00	1.94
Apron 3	Concrete	Undefined	1302'3875	3.800.00	2.668.00	1.94
Apron 3	Concrete	Undefined	1302'3875	3.800.00	2.618.00	1.94
Apron 3	Concrete	Undefined	1302'3875	3.800.00	2.668.00	1.94
Apron 3	Concrete	Undefined	1302'3875	3.800.00	2.618.00	1.94
Apron 3	Concrete	Undefined	1302'3875	3.800.00	2.668.00	1.94
Apron 3	Concrete	Undefined	1302'3875	3.800.00	2.618.00	1.94
Apron 3	Concrete	Undefined	1302'3875	3.800.00	2.668.00	1.94
Apron 3	Concrete	Undefined	1302'3875	3.800.00	2.618.00	1.94
Apron 3	Concrete	Undefined	1302'3875	3.800.00	2.668.00	1.94
Apron 3	Concrete	Undefined	1302'3875	3.800.00	2.618.00	1.94
Apron 3	Concrete	Undefined	1302'3875	3.800.00	2.668.00	1.94
Apron 3	Concrete	Undefined	1302'3875	3.800.00	2.618.00	1.94
Apron 3	Concrete	Undefined	1302'3875	3.800.00	2.668.00	1.94
Apron 3	Concrete	Undefined	1302'3875	3.800.00	2.618.00	1.94
Apron 3	Concrete	Undefined	1302'3875	3.800.00	2.668.00	1.94
Apron 3	Concrete	Undefined	1302'3875	3.800.00	2.618.00	1.94
Apron 3	Concrete	Undefined	1302'3875	3.800.00	2.668.00	1.94
Apron 3	Concrete	Undefined	1302'3875	3.800.00	2.618.00	1.94
Apron 3	Concrete	Undefined	1302'3875	3.800.00	2.668.00	1.94

The export results still need to be reprocessed using MS Excel. The following is a recap of the comparison of the volume of 1 block between RAB and the results of the design review of the implementation of Tekla BIM.

Table 3. Comparison of Volume 1 of RAB Block vs BIM

No.	Item Pekerjaan	Unit	BOQ	Review	Setelah	Keterangan
			Volume	Desain	BOQ -	
1	2	3	4	5	6	7
1	Steel Pipe Pile (SPP)	m	21.00	21.00	-	Desain yang dikunci / tidak berubah
2	Steel Pipe Sheet Pile	m	35.00	35.00	-	Desain yang dikunci / tidak berubah
3	Strut Members	m	13.00	13.00	-	Desain yang dikunci / tidak berubah
4	Deck Slab (Pier Head)	m ³	600.67	826.96	64.77	Volume review lebih kecil dari DED
5	Deck Slab (In-situ concrete)	m ³	20.33	22.40	2.07	Volume review lebih besar dari DED
6	Front wall	m ³	473.00	406.57	36.15	Volume review lebih kecil dari DED
7	Coping Concrete for SPSP	m ³	411.60	377.01	34.66	Volume review lebih kecil dari DED
8	PC Deck slab	m	190.00	190.00	-	Desain yang dikunci / tidak berubah
9	Apron Concrete	m ³	1,311.22	1,311.18	0.00	Volume hampir sama dengan DED

In the table, column number 4 is the volume obtained from the contract RAB when broken down into 9 blocks. Furthermore, in column number 5 is the volume of the final results of the design review of BIM-based implementation. As is known, the design of points number 1 (SPP), 2 (SPSP), 3 (Strut Members), and 8 (PC Deck Slab) is not a changed design when there is a clash detection or design inconsistency with the review, so it can be seen that the points in the blue columns 4, 6, and 7, namely the Deck Slab (Pier Head), Front Wall, and Copping Concrete for SPSP have a reduced volume than the initial volume of the RAB. However, there is one job that has experienced an increase in volume from RAB, namely at pink point 5, Deck Slab (In-Situ concrete). And for point 9, namely the Concrete Apron has a very close volume.

Since the result of 1 typical block of the Quay Wall Structure is known, then adjust the overall volume of the Quay Wall Structure by multiplying each volume by 9 blocks as can be observed in the following table.

Table 4. Comparison of Volume 9 of RAB vs BIM Blocks

No.	Item Pekerjaan	Unit	BOQ	Review	Setelah	Keterangan
			Volume	Desain	BOQ -	
1	2	3	4	5	6	7
1	Steel Pipe Pile (SPP)	m	189.00	189.00	-	Desain yang dikunci / tidak berubah
2	Steel Pipe Sheet Pile	m	315.00	315.00	-	Desain yang dikunci / tidak berubah
3	Strut Members	m	135.00	135.00	-	Desain yang dikunci / tidak berubah
4	Deck Slab (Pier Head)	m ³	5,196.00	7,523.10	962.90	Volume review lebih kecil dari DED
5	Deck Slab (In-situ concrete)	m ³	183.00	201.60	18.60	Volume review lebih besar dari DED
6	Front wall	m ³	4,257.00	3,921.53	205.17	Volume review lebih kecil dari DED
7	Coping Concrete for SPSP	m ³	3,707.00	3,393.09	313.91	Volume review lebih kecil dari DED
8	PC Deck slab	m	1,620.00	1,620.00	-	Desain yang dikunci / tidak berubah
9	Apron Concrete	m ³	11,801.00	11,800.69	0.21	Volume hampir sama dengan DED

Therefore, it is known that the final volume comparison data of the Quay Wall Structure results from the implementation of BIM.

Implementation of BIM 5D (Cost Analysis)

The implementation of BIM 5D (Cost Analysis) is the process of analyzing the results of processing BIM output data which is converted into costs. However, to find out the results of the data comparison after and before using BIM, the conventional data is processed by displaying the volume and amount of work prices using the help of Ms. Excel. The conventional calculation of the calculation of multiplying the unit price of RAB or contract is compared with the results of the Tekla design review.

The results of the volume quantity obtained from the implementation of BIM with Tekla will be analyzed using the same unit price as RAB. The final result will be displayed as in the following Table.

Table 5. RAB vs BIM Cost Comparison

No.	Nama Pekerjaan	Unit	RAB		Review Desain Tekla		Selisih RAB - Review Desain	Persentase Perubahan (%)
			Jumlah	Jumlah Harga (Rp)	Volume	Jumlah Harga (Rp)		
1	Steel Pipe (R)	m	180.00	-	180.00	-	-	-
2	Steel Pipe (S)	m	915.00	-	915.00	-	-	-
3	Steel Manhole	m	180.00	-	180.00	-	-	-
4	Steel Deck (R)	m ²	81.00	19.811.713.000,00	1.025.10	85.942.407.391,28	6.078.104.879,28	30,69%
5	Steel Deck (S)	m ²	180.00	1.026.886.448,00	201.80	1.871.700.860,00	1.844.814.412,00	18,00%
6	Form wall	m ²	4.287,00	37.005.413.070,00	3.004,83	34.248.040.020,38	2.003.377.549,72	5,42%
7	Casting Concrete for SP&P	m ³	3.707,00	33.300.381.070,00	3.580,00	30.545.720.640,00	2.754.660.430,00	8,27%
8	PC Deck slab	m ²	1.800,00	-	1.800,00	-	-	-
9	Raport Concrete	m ³	11.801,00	1.238.420.780,00	11.800,00	1.218.428.080,00	199.743,78	0,02%
Total Jumlah Harga				548.731.420.830,00		138.120.592.626,45	18.892.818.303,55	3,44%
Tertimbang								

5

Based on the results of the clash detection analysis and its completion, the work items that undergo changes in the volume of materials so that they affect the material costs that have been presented in the table, are as much as the cost of 7.06% (percent) of the total initial cost of the Quay Wall Structure. The difference in cost is around IDR 10,502,919,303.55 (Ten billion five hundred two million nine hundred nineteen thousand three hundred three rupiah fifty-five).

Comparative costs have been identified for each category of clashes. Averaging is considered for all categories to allow for a volume addendum in the project. The results obtained will be extrapolated to the overall cost savings achieved by this particular case study.

CONCLUSION

Based on the initial and final descriptions of the research that has been carried out regarding the Implementation of the 5D Building Information Modelling (BIM) System in Quay Wall Structure with Attention to Clash Detection (Case Study: Project Patimban Package 6), the following conclusions can be drawn:

1. The implementation of BIM 5D is essential in the pre-construction stage to ensure that the design is applicable and in accordance with the work plan, thereby reducing the potential for errors and improving project efficiency.
2. The results of clash detection identification showed that some work items such as Deck Slab (Pier Head), Front Wall, and Coping Concrete for SPSP experienced a decrease in volume compared to the initial RAB, while Deck Slab (In-Situ Concrete) experienced an increase in volume. This process helps in identifying potential problems early on and allows for necessary corrective action.
3. Based on the comparison between the volume of RAB and the results of the design review with Tekla BIM, it was found that there was a significant change in volume in several work items. This shows that the use of BIM in the design process can provide more accurate volume estimates.
4. The implementation of BIM 5D shows a cost saving of 7.06% of the total initial cost of the Quay Wall Structure, which is equivalent to IDR 10,502,919,303.55. Changes in material volume are identified through clash detection, which shows the great potential of BIM to improve cost efficiency in construction projects.
5. The implementation of BIM 5D with clash detection can identify and resolve potential clashes in the design during the contract design review, which can potentially reduce construction work errors occurring during the construction phase.
6. The use of BIM can be a means of assistance in better planning and coordination between project teams, which ultimately improves the efficiency and effectiveness of overall project execution.

REFERENCES

- Al-Ashmori, Y. Y., Othman, I., Rahmawati, Y., Amran, Y. H. M., Sabah, S. H. A., Rafindadi, A. D. u., & Mikić, M. (2020). BIM benefits and its influence on the BIM implementation in Malaysia. *Ain Shams Engineering Journal*, 11(4), 1013–1019. <https://doi.org/10.1016/j.asej.2020.02.002>
- Bryman, A. (2016). *Social Research Methods - Alan Bryman - Oxford University Press*. In Oxford University Press.
- Fahirah, F., & Tlantan, J. S. (2022). Identification of Risks Affecting the Implementation of Road Construction Projects in Palu City Based on Consultants' Perceptions. *TADULAKO RECONSTRUCTION: Civil Engineering Journal on Research and Development*. <https://doi.org/10.22487/renstra.v3i1.411>
- Jumadianto, Soedarsono, & Adhy, D. S. (2017). Analysis of the Application of Review Design in the Leachate Pond Construction Project. *Proceedings of the National Seminar on Innovation in the Development of SmartCity*, 1(1).
- Liu, P., Liu, C., Zhang, S., Wang, Y., & Wang, Q. (2022). Depth-varying corrosion characteristics and stability bearing capacity of steel pipe piles under aggressive marine environment. *Ocean Engineering*, 266, <https://doi.org/10.1016/j.oceaneng.2022.112649>
- Muhammad Rafli Alrizqi, & Ilham Fazri. (2023). Content uploaded by Muhammad

Rafli Alrizqi Content may be subject to copyright.

Natasha, I., & Makarim, C. A. (2018). ANALYSIS OF PILE FAILURE IN DOCK CONSTRUCTION WITH APILE OFFSHORE, LPILE, AND GRLWEAP PROGRAMS. In *Jurnal Mitra Teknik Sipil* (Vol. 1, Issue 1).

Government Regulation Number 31. (2021). PRESIDENT OF THE REPUBLIC OF INDONESIA, in order to implement the provisions of Article 5T and Article 185 letter b of Law Number 11 of 2020 concerning Job Creation, it is necessary to establish a Government Regulation on.

Rayendra, Biemo W., & Soemardi. (n.d.). APPLICATION STUDY OF BUILDING INFORMATION MODELING TECHNOLOGY FOR PRE-CONSTRUCTION.

Palencia

ORIGINALITY REPORT

6%

SIMILARITY INDEX

5%

INTERNET SOURCES

1%

PUBLICATIONS

3%

STUDENT PAPERS

PRIMARY SOURCES

1	investor.wikagedung.co.id Internet Source	2%
2	www.researchgate.net Internet Source	1%
3	Submitted to IUBH - Internationale Hochschule Bad Honnef-Bonn Student Paper	1%
4	Submitted to School of Business and Management ITB Student Paper	1%
5	garuda.kemdikbud.go.id Internet Source	<1%
6	www.hrpub.org Internet Source	<1%
7	www.open-access.bcu.ac.uk Internet Source	<1%

Exclude quotes

Off

Exclude matches

Off

Exclude bibliography On